



Grizzly 36

Tree Cutter

Published (06 - 05)

Part No. 02972891P

Grizzly

*Tree
Cutter*

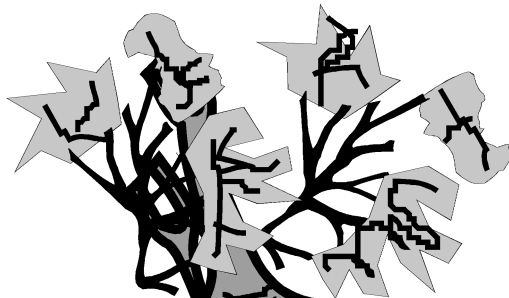

OPERATOR'S MANUAL with PARTS LISTING

ALAMO INDUSTRIAL

1502 E. Walnut
Seguin, Texas 78155
830-379-1480

An Alamo Group Company

© 2005 Alamo Group Inc.

TO THE OWNER/OPERATOR/DEALER

All implements with moving parts are potentially hazardous. There is no substitute for a cautious, safe-minded operator who recognizes the potential hazards and follows reasonable safety practices. The manufacturer has designed this implement to be used with all its safety equipment properly attached to minimize the chance of accidents.

BEFORE YOU START!! Read the safety messages on the implement and shown in your manual.
Observe the rules of safety and common sense!

 DANGER			
FAILING TO FOLLOW SAFETY MESSAGES AND OPERATING INSTRUCTIONS CAN CAUSE SERIOUS BODILY INJURY OR EVEN DEATH TO OPERATOR AND OTHERS IN THE AREA.			
1. 	2. NO RIDERS. NO CHILDREN OPERATORS. 	3. USE SAFETY SHOES, HARD HAT, SAFETY GLASSES, SEAT BELTS, & ROPS 	4. BLOCK UP SECURELY BEFORE WORKING UNDER. 
<p>1. Study and understand operator's manual, safety signs, and instructional decals for tractor and implement to prevent misuse, abuse, and accidents. • Learn how to stop engine suddenly in an emergency. Be alert for passerby and especially children.</p> <p>2. Allow no children on or near implement or tractor. Allow no riders on tractor and implement. Falling off may cause serious injury or death from being run over by tractor or cutter or contact with rotating blades.</p> <p>3. Operate only with tractor having Roll-Over Protective Structure (ROPS) and with seatbelt fastened securely and snugly to prevent injury and possible death from falling off or tractor overturn. Personal Protective Equipment such as Hard Hat, Safety Glasses, Safety Shoes, and Ear Plugs are Recommended.</p> <p>4. Block up or support raised machine and all lifted components securely before putting hands or feet under or working underneath any lifted components to prevent crushing injury or death from sudden dropping or inadvertent operation of controls. Make certain area is clear before lowering or folding.</p> <p>5. Before transporting, put Lift Lever in detent or full-lift position. Secure the implement for transport by installing Cylinder Stops or Transport Pin on Pull-type implement center axle and Wing Transport Locks on folding implements. • Attach Safety Chain to cutter and towing unit securely. See Operator's Manual.</p> <p>6. Make certain that the SMV sign, Warning Lights, and Reflectors are clearly visible. Follow local traffic codes.</p> <p>7. Never operate with Cutting Head raised if passerby, bystanders, or traffic are in the area to reduce possibility of injury or death from Objects thrown by Blades under Guard or cutter structure.</p> <p>8. Before dismounting, secure implement in transport position or lower to ground. • Put tractor in park or set the brake, disengage PTO, stop engine, and remove key, and wait until noise of rotation has ceased to prevent entanglement in rotating parts which can cause injury or death. • Never mount or dismount a moving vehicle. Crushing from runover may cause injury or death.</p>			
5. TRANSPORT SAFELY, LOCK UP. 	6. USE SMV LIGHTS, & REFLECTORS. 	7. DO NOT OPERATE WITH CUTTER OR WING RAISED. 	8. DO NOT MOUNT OR DISMOUNT WHILE MOVING. 
00749117			

WARRANTY INFORMATION:

Read and understand the complete Warranty Statement found in this Manual. Fill out the Warranty Registration Form in full and return it to within 30 Days. Make certain the Serial Number of the Machine is recorded on the Warranty Card and on the Warranty Form that you retain.

PARTS ORDERING GUIDE

The following instructions are offered to help eliminate needless delay and error in processing purchase orders for the equipment in this section.

1. The Parts Section is prepared in logical sequence and grouping of parts that belong to the basic machine featured in this manual. Part Numbers and Descriptions are given to help locate the parts and quantities required.
2. The Purchase Order must include the name and address of the person or organization ordering the parts, who should be charged, and if possible, the serial number of the machine for which the parts are ordered.
3. The Purchase Order must clearly list the quantity of each part, the complete and correct part number (be sure to include all periods), and the basic name of the part.
4. The Manufacturer reserves the right to substitute parts where applicable.
5. Some parts are unlisted items which are special production items not normally stocked and are subject to special handling. Request a quotation for such parts before sending a Purchase Order.
6. The Manufacturer reserves the right to change prices without prior notice.

NOTE: Please refer to The Safety Section in the front of this Manual for the proper Part Number when ordering Replacement Safety Decals.



For maximum safety and to guarantee optimum product reliability, always use genuine Servis-Rhino Parts. The use of inferior replacement parts may cause premature or catastrophic failure which could result in serious injury or death. Direct any questions regarding parts to:

ALAMO INDUSTRIAL

ALAMO INDUSTRIAL

1502 E. Walnut
Seguin, Texas 78155
830-379-1480



PARTS SECTION

PART NAME INDEX

BEARING HOUSING ASSEMBLY	9
BEARING HOUSING ASSEMBLY - SERIES II FRAME	10
BRUSHCUTTER - LIGHT MODEL	6
CROSS-OVER RELIEF & CIRCULATING VALVE	8
GENERAL ASY. - BAR CARRIER	5
GENERAL ASY. - MULCHING DISC	4
MULCHING AND COUPLING ASSEMBLY	12
MULCHING DISC ASSEMBLY	11
SAFETY - CANISTER	14
SAFETY - DECAL LOCATION	13

GENERAL ASY. - MULCHING DISC

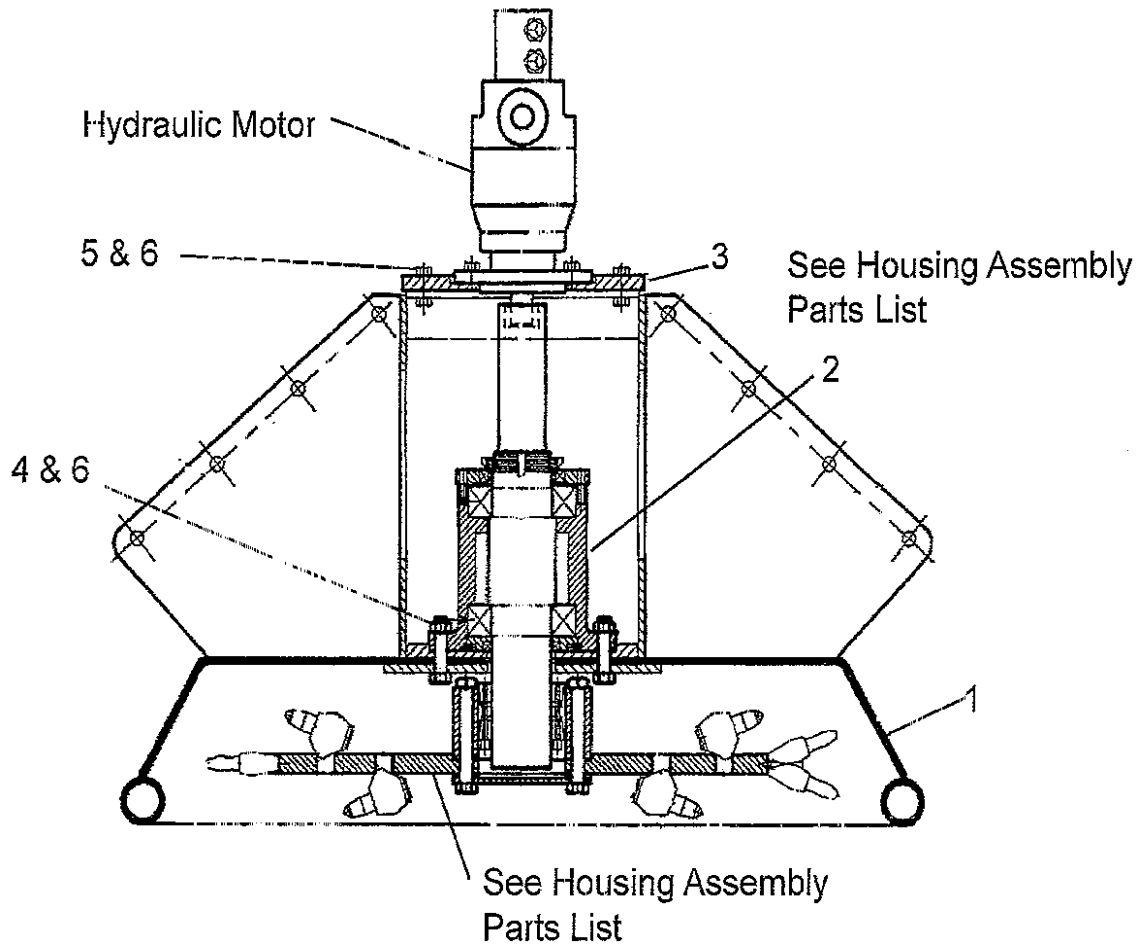

ITEM	PART NO.	QTY.	DESCRIPTION
1	02973184	1	FRAME WLDMT - MODEL 36"
2	02972913	1	BEARING HOUSING ASY.
3	02972916	1	MOTOR MOUNTING PLATE
4	03200269	6	BOLT
5	02918600	4	BOLT
6	00037200	10	LOCKNUT

GENERAL ASY. - BAR CARRIER

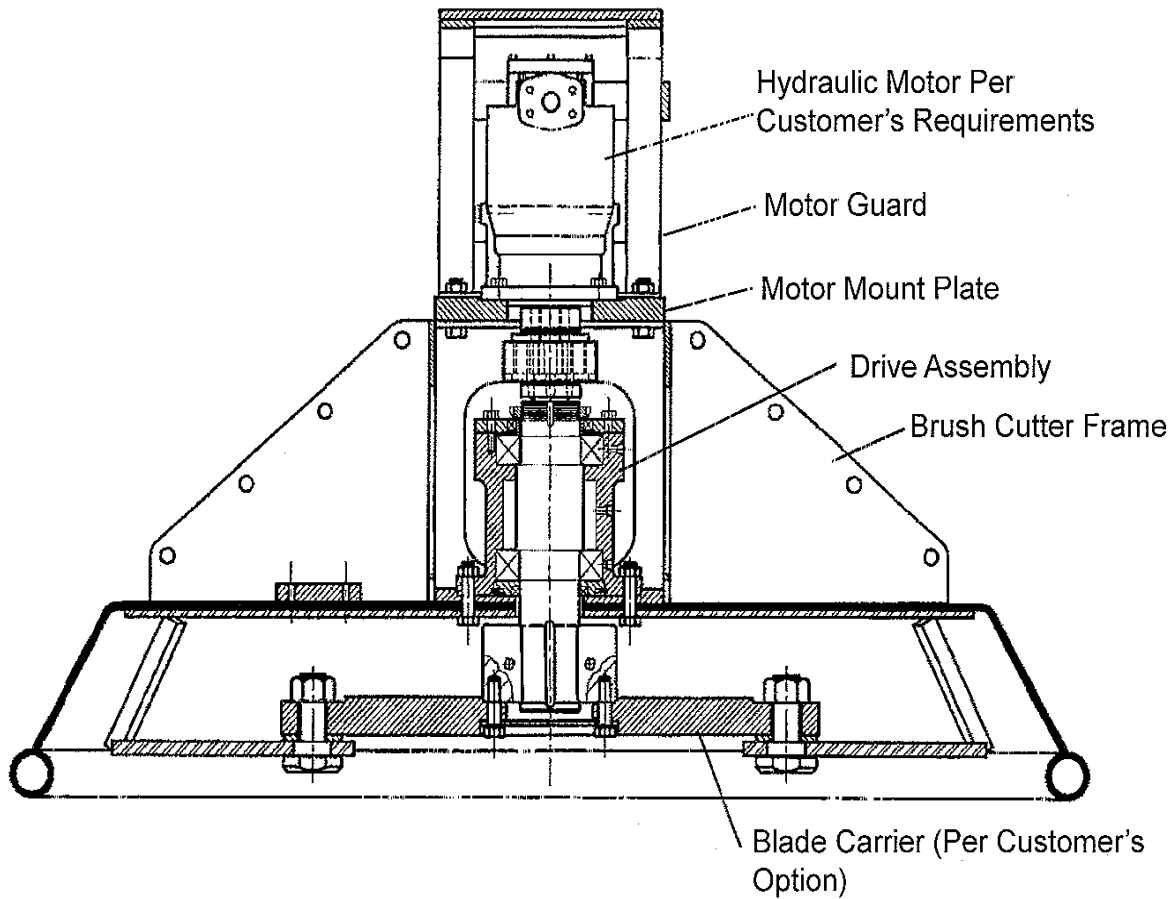

ITEM	PART NO.	QTY.	DESCRIPTION
1	-----	---	* GENERAL ASY. - W/ BLADE CARRIER (OPTIONAL)

BRUSHCUTTER - LIGHT MODEL

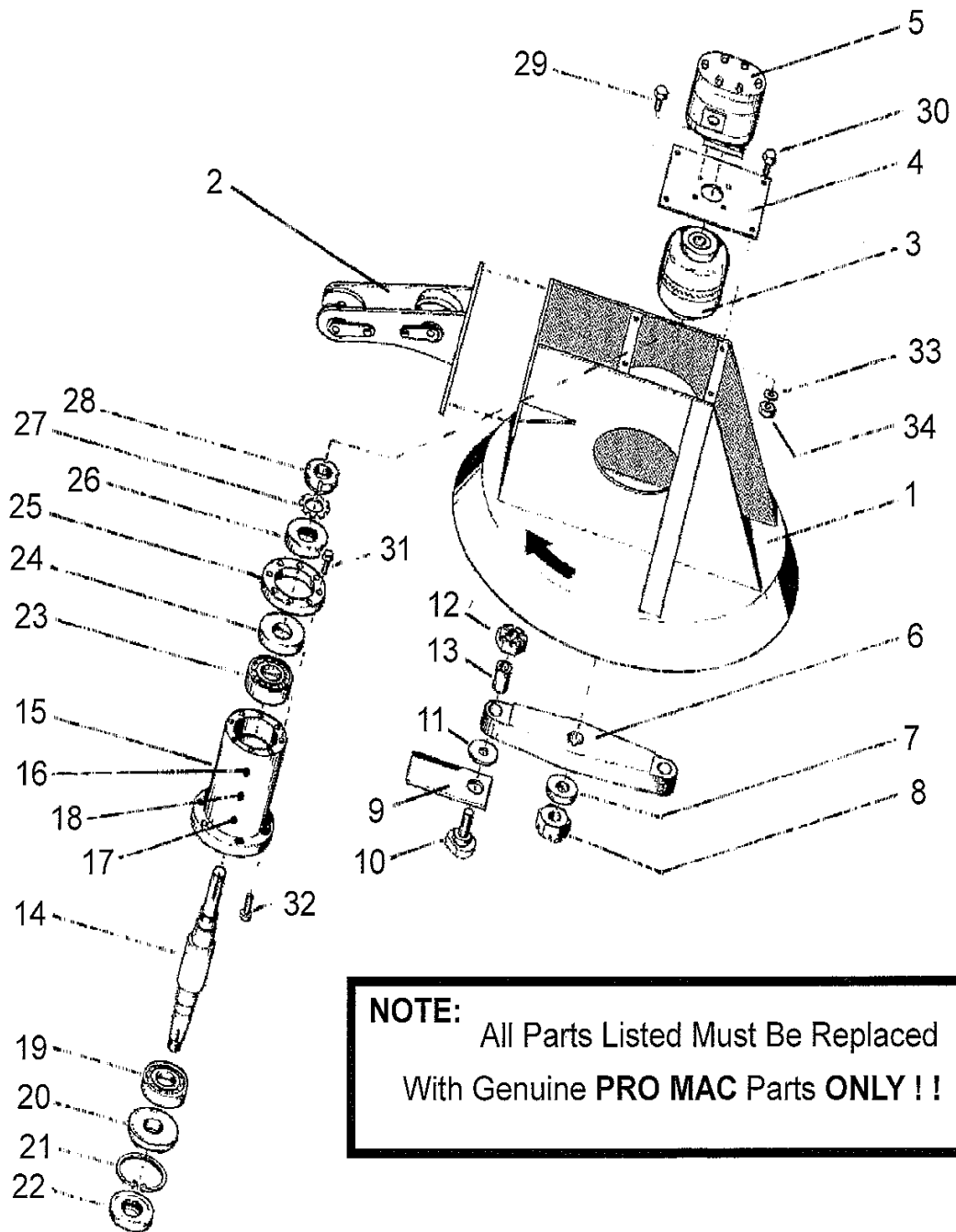

NOTE: All Parts Listed Must Be Replaced
With Genuine **PRO MAC** Parts **ONLY !!**

BRUSHCUTTER - LIGHT MODEL

ITEM	PART NO.	QTY.	DESCRIPTION
1	02975068	1	MAIN FRAME
2	-----	1	ADAPTER FRAME
3	02975069	1	COUPLING
	02975161	1	LOWER FLANGE
	02975162	1	UPPER FLANGE
	02975163	1	ELEMENT
	02975164	1	SHAFT BUSHING
	02975165	1	MOTOR BUSHING
	02975166	1	MOTOR BUSHING - SPLINED
4	02975070	1	BASE PLATE
5	02975185	1	MOTOR
6	02975071	1	BLADE BAR
7	02975084	1	WASHER
8	5D20120	1	SLOTTED NUT
9	02975072	2	KNIFE BLADE
10	02975073	2	BLADE BOLT
11	02975085	2	WASHER
12	5D20120	2	SLOTTED NUT
13	02975074	2	BUSHING
14	02975075	1	SHAFT
15	02975076	1	BEARING HOUSING
16	00003500	1	GREASE FITTING
17	02026800	1	GREASE FITTING 45 DEG
18	02959018	1	RELEASE VALVE
19	02975077	1	LOWER BEARING
20	02975078	1	LOWER COVER
21	02975079	1	RETAINING RING
22	02975080	1	LOWER SEAL
23	02975077	1	UPPER BEARING
24	02975081	1	BUSHING
25	02975082	1	UPPER COVER
26	02975083	1	UPPER SEAL
27	02909600	1	LOCKWASHER
28	02909500	1	SLOTTED NUT
29	02892000	4	MOTOR BOLT
30	00013300	4	FRAME BOLT
31	00753642	8	COVER BOLT
32	02788400	6	HOUSING BOLT
33	00001300	10	LOCKWASHER
34	00001800	10	LOCKNUT

CROSS-OVER RELIEF & CIRCULATING VALVE

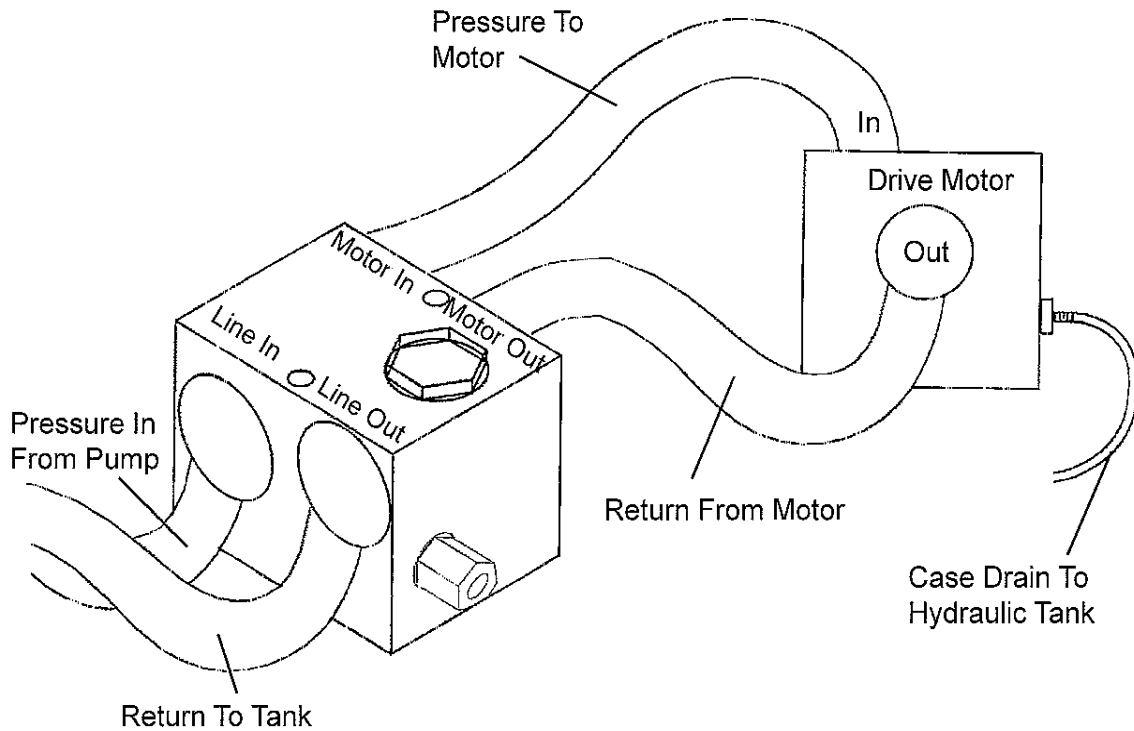

High Pressure: P/N 02973213
Low Pressure: P/N 02973214

ITEM	PART NO.	QTY.	DESCRIPTION
1	02973213	---	HIGH PRESSURE RELIEF VALVE
	02973214	---	LOW PRESSURE RELIEF VALVE

BEARING HOUSING ASSEMBLY

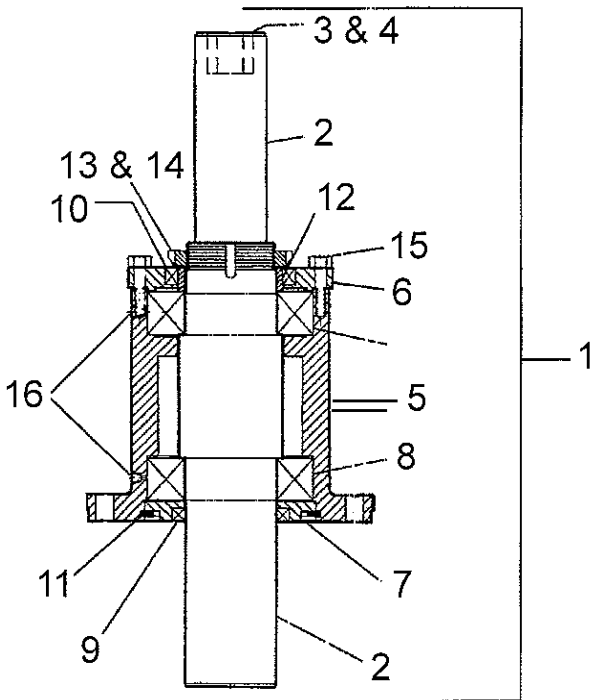

ITEM	PART NO.	QTY.	DESCRIPTION
1	02972913	1	BEARING HOUSING ASY.
2	02972914	1	SHAFT
3	02972915	1	SPLINED SHAFT, INSERT
4	02972917	1	SNAP RING, INSERT
5	02972918	1	BEARING HOUSING
6	02972919	1	TOP COVER
7	02972920	1	BOTTOM COVER
8	02972921	2	BEARING
9	02972922	1	LOWER SEAL
10	02972923	1	UPPER SEAL
11	02972924	1	RETAINER RING
12	02972925	1	SPACER
13	02972926	1	BEARING NUT
14	02972927	1	BEARING NUT WASHER
15	02972949	8	BOLT
16	02972928	2	GREASE FITTING

BEARING HOUSING ASSEMBLY - SERIES II FRAME

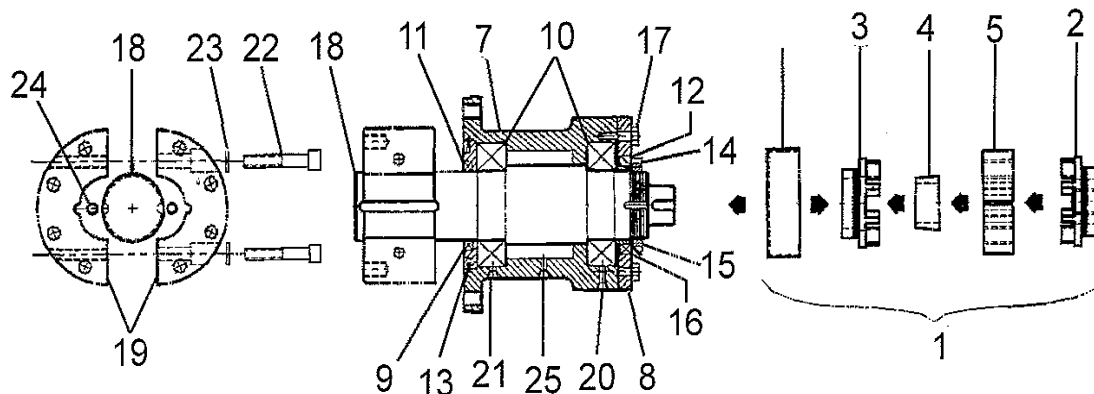

ITEM	PART NO.	QTY.	DESCRIPTION
1	02975025	1	QUICK FLEX COUPLING ASY.
2	02975026	1	COUPLING SPLINED HUB
3	02975027	1	COUPLING TAPER LOCK HUB
4	02975028	1	COUPLING TAPER LOCK BUSHING
5	02975029	1	COUPLING RED INSERT
6	02975030	1	COUPLING COVER
7	02972918	1	HOUSING BEARING
8	02972919	1	TOP COVER
9	02972920	1	BOTTOM COVER
10	02972921	2	BEARING
11	02972922	1	LOWER SEAL
12	02972923	1	UPPER SEAL
13	02972924	1	RETAINER RING
14	02972925	1	SPACER
15	02972926	1	BEARING NUT
16	02972927	1	BEARING NUT WASHER
17	02972949	8	BOLT
18	02975031	1	SHORT COUPLING SHAFT
19	02975032	1	CLAMP HUB
20	02026800	1	GREASE FITTING, 45 DEG.
21	00003500	1	GREASE FITTING, STRAIGHT
22	02975033	2	BOLT
23	00010300	2	LOCKWASHER
24	02975034	2	ROUND KEY
25	02959018	1	GREASE RELIEF FITTING

MULCHING DISC ASSEMBLY

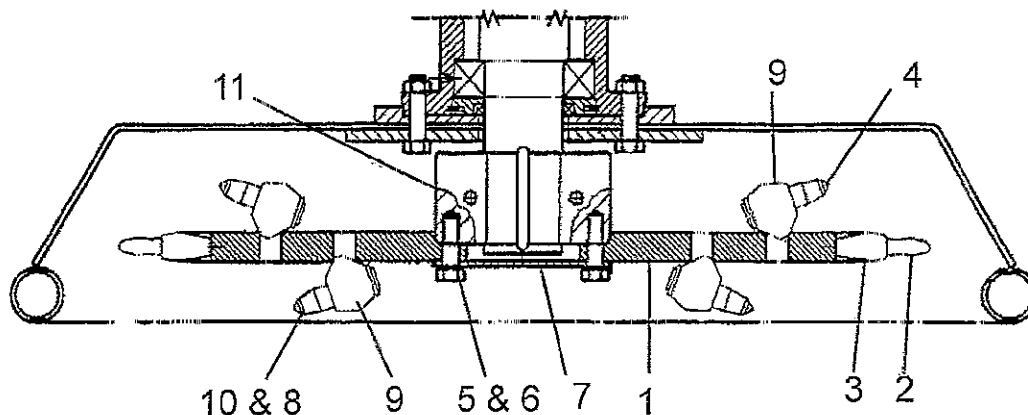

ITEM	PART NO.	QTY.	DESCRIPTION
1	02973185	1	MULCHING DISC, 36"
2	02972933	6	OUTER CUTTER BIT
3	02972934	6	MODIFIED OUTER MOUNTING BLOCK
4	02972935	6	UPPER CUTTER BIT
5	02963646	8	BOLT
6	00003901	8	LOCKWASHER
7	02972931	1	DUST COVER
8	02972939 *	6	HEAVY DUTY BULLET BIT (OPTIONAL)
9	02972940 *	6	HEAVY DUTY MOUNTING BLOCK (OPTIONAL)
10	02972941 *	6	HEAVY DUTY CUP BIT (OPTIONAL)
11	02975032	1	CLAMP HUB

MULCHING AND COUPLING ASSEMBLY

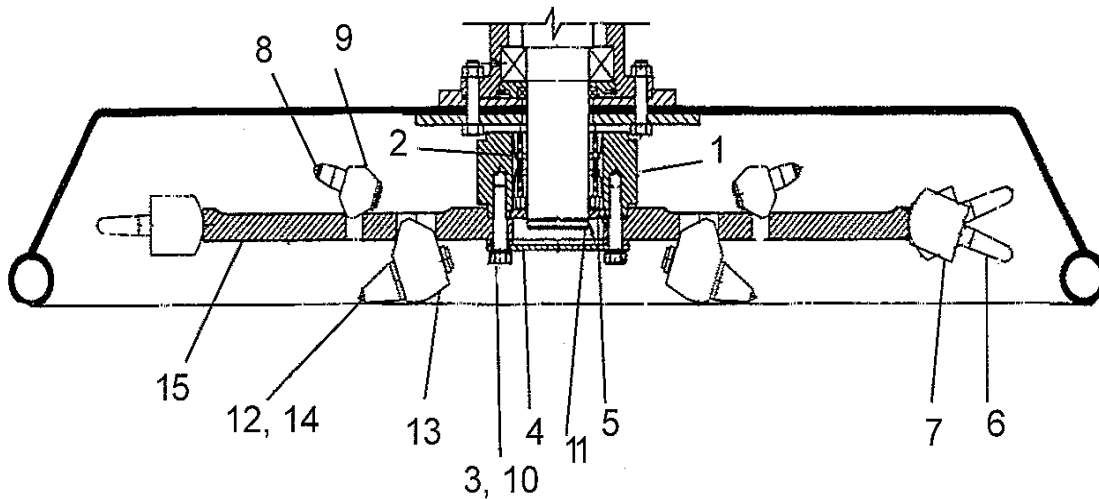

ITEM	PART NO.	QTY.	DESCRIPTION
1	02972929	1	MULTI-PURPOSE COUPLING HUB
2	02972930	1	LOCK ASSEMBLY
3	03200269	8	BOLT
4	02972931	1	DUST COVER / SHAFT END COVER
5	02972932	1	SAFETY PLATE
6	02972933	6	OUTER CUTTER BIT
7	02972934	6	MODIFIED OUTER MOUNTING BLOCK
8	02972935	4	UPPER CUTTER BIT
9	02972936	4	HD BLOCK
10	00003901	6	LOCKWASHER
11	02972938	1	SNAP RING
12	02972939 *	6	HEAVY DUTY, FLARED BIT (OPTIONAL)
13	02972940 *	6	HEAVY DUTY, FACE BLOCK (OPTIONAL)
14	02972941 *	6	HEAVY DUTY, CUP BIT (OPTIONAL)
15	02973185	1	MULCHING DISC 36" (W/O CUTTERS)

SAFETY - DECAL LOCATION

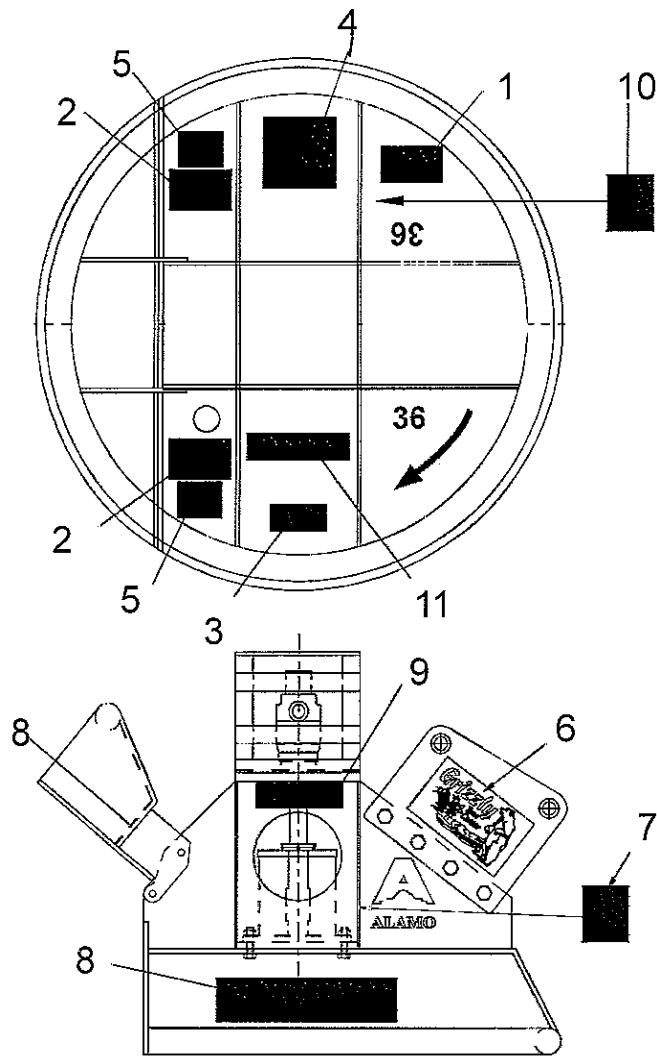

ITEM	PART NO.	QTY.	DESCRIPTION
1	00769736	1	DECAL - WARNING - USE/REPAIR SHIELD & GUARDS
2	00769737	2	DECAL - DANGER - CUTTING BLADES/THROWN OBJECTS
3	02925100	1	DECAL - IMPORTANT - GENUINE PARTS
4	02967827	1	DECAL - DANGER - MULTI-HAZARD
5	02967867	2	DECAL - DANGER - SAFETY GATE OPERATION
6	02972284	2	DECAL - LOGO - GRIZZLY TREE CUTTER
7	02965262	1	DECAL - WARNING - HOSE BURST
8	02973050	3	DECAL - DANGER - DANGER STAND CLEAR
9	02973051	1	DECAL - INSTRUCT - READ OPERATORS INSTRUCTIONS
10	02973052	1	DECAL - DANGER - KEEP CLEAR OVER HEAD WIRES
11	00725746	1	DECAL - PELIGRO! SPANISH TRANSLATION

SAFETY - CANISTER

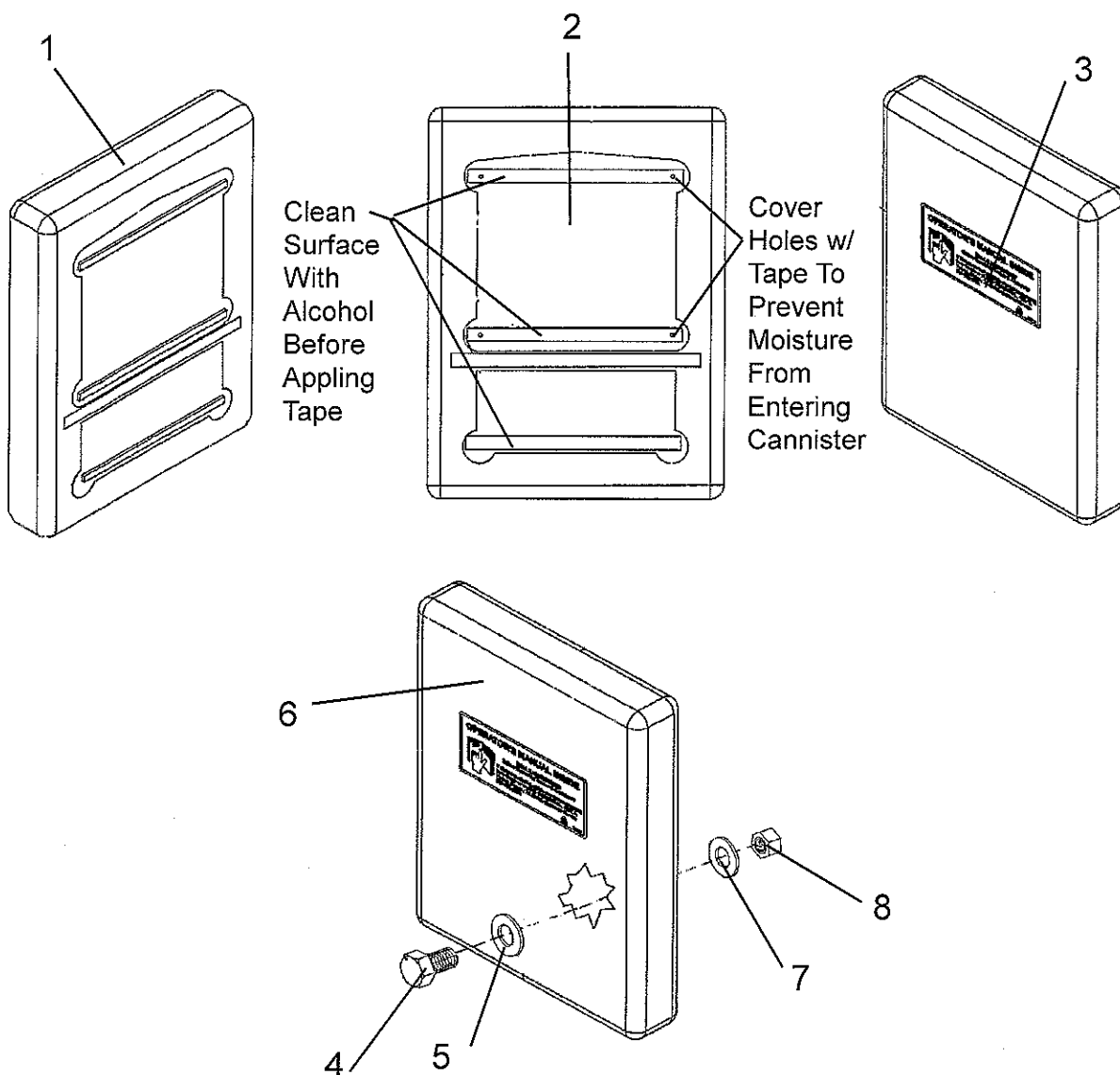

ITEM	PART NO.	QTY.	DESCRIPTION
1	02977385	1	CANISTER
2	02968143	2.5	TAPE 3M BACK TO BACK
3	02977417	1	DECAL, OPERATORS MANUAL INSIDE
4	10058000	4	BOLT
5	00024100	4	FLATWASHER
6	02967444C	4	OPERATORS MANUAL (INSIDE)
7	00017000	4	LOCKWASHER
8	02959924	4	LOCKNUT

Alamo Industrial

LIMITED WARRANTY

1. LIMITED WARRANTIES

- 1.01. Servis-Rhino warrants for one year from the purchase date to the original non-commercial, governmental, or municipal purchaser ("Purchaser") and warrants for six months to the original commercial or industrial purchaser ("Purchaser") that the goods purchased are free from defects in material or workmanship.
- 1.02. Manufacturer will replace for the Purchaser any part or parts found, upon examination at one of its factories, to be defective under normal use and service due to defects in material or workmanship.
- 1.03. This limited warranty does not apply to any part of the goods which has been subjected to improper or abnormal use, negligence, alteration, modification, or accident, damaged due to lack of maintenance or use of wrong fuel, oil, or lubricants, or which has served its normal life. This limited warranty does not apply to any part of any internal combustion engine, or expendable items such as blades, shields, guards, or pneumatic tires except as specifically found in your Operator's Manual.
- 1.04. Except as provided herein, no employee, agent, Dealer, or other person is authorized to give any warranties of any nature on behalf of Manufacturer.

2. REMEDIES AND PROCEDURES.

- 2.01. This limited warranty is not effective unless the Purchaser returns the Registration and Warranty Form to Manufacturer within 30 days of purchase.
- 2.02. Purchaser claims must be made in writing to the Authorized Dealer ("Dealer") from whom Purchaser purchased the goods or an approved Authorized Dealer ("Dealer") within 30 days after Purchaser learns of the facts on which the claim is based.
- 2.03. Purchaser is responsible for returning the goods in question to the Dealer.
- 2.04. If after examining the goods and/or parts in question, Manufacturer finds them to be defective under normal use and service due to defects in material or workmanship, Manufacturer will:
 - (a) Repair or replace the defective goods or part(s) or
 - (b) Reimburse Purchaser for the cost of the part(s) and reasonable labor charges (as determined by Manufacturer) if Purchaser paid for the repair and/or replacement prior to the final determination of applicability of the warranty by Manufacturer.The choice of remedy shall belong to Manufacturer.
- 2.05. Purchaser is responsible for any labor charges exceeding a reasonable amount as determined by Manufacturer and for returning the goods to the Dealer, whether or not the claim is approved. Purchaser is responsible for the transportation cost for the goods or part(s) from the Dealer to the designated factory.

3. LIMITATION OF LIABILITY.

- 3.01. MANUFACTURER DISCLAIMS ANY EXPRESS (EXCEPT AS SET FORTH HEREIN) AND IMPLIED WARRANTIES WITH RESPECT TO THE GOODS INCLUDING, BUT NOT LIMITED TO, MERCHANTABILITY AND FITNESS FOR A PARTICULAR PURPOSE.
- 3.02. MANUFACTURER MAKES NO WARRANTY AS TO THE DESIGN, CAPABILITY, CAPACITY, OR SUITABILITY FOR USE OF THE GOODS.
- 3.03. EXCEPT AS PROVIDED HEREIN, MANUFACTURER SHALL HAVE NO LIABILITY OR RESPONSIBILITY TO PURCHASER OR ANY OTHER PERSON OR ENTITY WITH RESPECT TO ANY LIABILITY, LOSS, OR DAMAGE CAUSED OR ALLEGED TO BE CAUSED DIRECTLY OR INDIRECTLY BY THE GOODS INCLUDING, BUT NOT LIMITED TO, ANY INDIRECT, SPECIAL, CONSEQUENTIAL, OR INCIDENTAL DAMAGES RESULTING FROM THE USE OR OPERATION OF THE GOODS OR ANY BREACH OF THIS WARRANTY. NOTWITHSTANDING THE ABOVE LIMITATIONS AND WARRANTIES, MANUFACTURER'S LIABILITY HEREUNDER FOR DAMAGES INCURRED BY PURCHASER OR OTHERS SHALL NOT EXCEED THE PRICE OF THE GOODS.
- 3.04. NO ACTION ARISING OUT OF ANY CLAIMED BREACH OF THIS WARRANTY OR TRANSACTIONS UNDER THIS WARRANTY MAY BE BROUGHT MORE THAN TWO (2) YEARS AFTER THE CAUSE OF ACTION HAS OCCURRED.

4. MISCELLANEOUS.

- 4.01. Proper Venue for any lawsuits arising from or related to this limited warranty shall be only in Guadalupe County, Texas.
- 4.02. Manufacturer may waive compliance with any of the terms of this limited warranty, but no waiver of any terms shall be deemed to be a waiver of any other term.
- 4.03. If any provision of this limited warranty shall violate any applicable law and is held to be unenforceable, then the invalidity of such provision shall not invalidate any other provisions herein.
- 4.04. Applicable law may provide rights and benefits to purchaser in addition to those provided herein.

KEEP FOR YOUR RECORDS

ATTENTION: Purchaser should fill in the blanks below for his reference when buying repair parts and/or for proper machine identification when applying for warranty.

Servis-Rhino Implement Model _____ Serial Number _____

Date Purchased _____ Dealer _____

ATTENTION:
READ YOUR OPERATOR'S MANUAL





TO THE OWNER/OPERATOR/DEALER

To keep your implement running efficiently and safely, read your manual thoroughly and follow these directions and the Safety Messages in this Manual. The Table of Contents clearly identifies each section where you can easily find the information you need.

The OCCUPATIONAL SAFETY AND HEALTH ACT (1928.51 Subpart C) makes these minimum safety requirements of tractor operators:

REQUIRED OF THE OWNER:

1. Provide a Roll-Over-Protective Structure that meets the requirements of this Standard; and
2. Provide Seatbelts that meet the requirements of this paragraph of this Standard and SAE J4C; and
3. Ensure that each employee uses such Seatbelt while the tractor is moving; and
4. Ensure that each employee tightens the Seatbelt sufficiently to confine the employee to the protected area provided by the ROPS.

REQUIRED OF THE OPERATOR

1. Securely fasten seatbelt if the tractor has a ROPS.
2. Where possible, avoid operating the tractor near ditches, embankments, and holes.
3. Reduce speed when turning, crossing slopes, and on rough, slick, or muddy surfaces.
4. Stay off slopes too steep for safe operation.
5. Watch where you are going - especially at row ends, on roads, and around trees.
6. Do not permit others to ride.
7. Operate the tractor smoothly - no jerky turns, starts, or stops.
8. Hitch only to the drawbar and hitch points recommended by the tractor manufacturer.
9. When the tractor is stopped, set brakes securely and use park lock, if available.



Keep children away from danger all day, every day...



Equip tractors with rollover protection (ROPS) and keep all machinery guards in place...



Please work, drive, play and live each day with care and concern for your safety and that of your family and fellow citizens.



Grizzly 36 (06/05)

© 2005 Alamo Group Inc.