



# Snow Blower

Published 08-05

P/N 5042P

## PART'S MANUAL

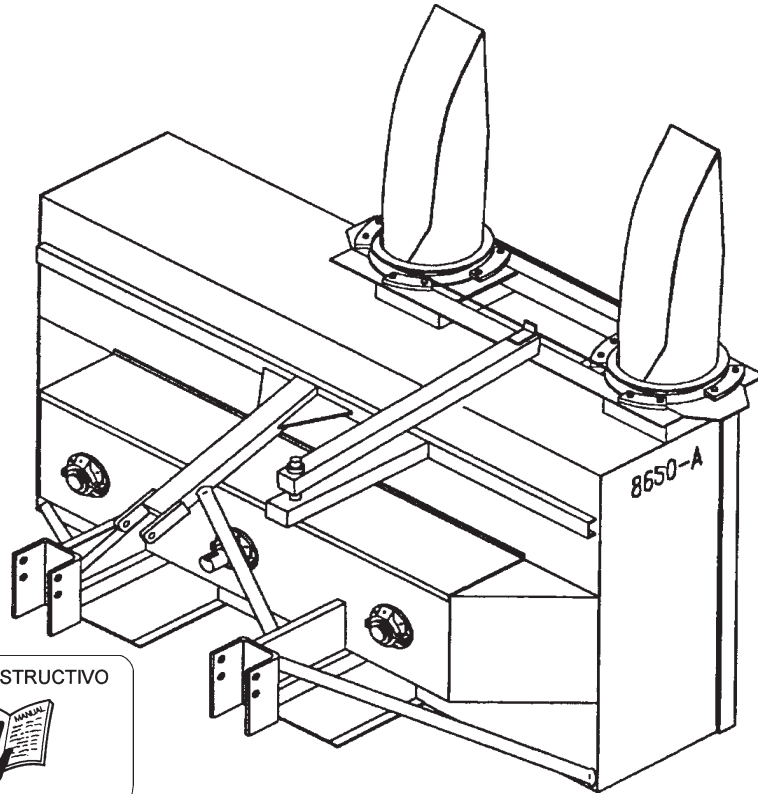

### ATENCIÓN!

LEA EL INSTRUCTIVO

Si No Lee Ingles, Pida Ayuda a Alguien Que Si Lo Lea Para Que le Traduzca las Medidas de Seguridad.



An Operator's Manual was shipped with the equipment in the Manual Canister. This Operator's Manual is an integral part of the safe operation of this machine and must be maintained with the unit at all times. **READ, UNDERSTAND, and FOLLOW** the Safety and Operation Instructions contained in this manual before operating the equipment. If the Operator's Manual is not with the equipment, contact your dealer or Alamo Industrial (830-379-1480) to obtain a copy before operating the equipment.

## ALAMO INDUSTRIAL

1502 E. Walnut  
Seguin, Texas 78155  
830-379-1480

© 2005 Alamo Industrial







# TO THE OWNER/OPERATOR/DEALER

All implements with moving parts are potentially hazardous. There is no substitute for a cautious, safe-minded operator who recognizes the potential hazards and follows reasonable safety practices. The manufacturer has designed this implement to be used with all its safety equipment properly attached to minimize the chance of accidents.

**BEFORE YOU START!!** Read the safety messages on the implement and shown in your manual. Observe the rules of safety and common sense!

**DANGER**

FAILING TO FOLLOW SAFETY MESSAGES AND OPERATING INSTRUCTIONS CAN CAUSE SERIOUS BODILY INJURY OR EVEN DEATH TO OPERATOR AND OTHERS IN THE AREA.

<p><b>1.</b></p>	<p><b>2. NO RIDERS. NO CHILDREN OPERATORS.</b></p>	<p><b>3. USE SAFETY SHOES, HARD HAT, SAFETY GLASSES, SEAT BELTS, &amp; ROPS</b></p>	<p><b>4. BLOCK UP SECURELY BEFORE WORKING UNDER.</b></p>
------------------	--	---	--

1. Study and understand operator's manual, safety signs, and Instructional decals for tractor and implement to prevent misuse, abuse, and accidents.  
 • Learn how to stop engine suddenly in an emergency. Be alert for passerby and especially children.

2. Allow no children on or near implement or tractor. Allow no riders on tractor and implement. Falling off may cause serious injury or death from being run over by tractor or cutter or contact with rotating blades.

3. Operate only with tractor having Roll-Over Protective Structure (ROPS) and with seatbelt fastened securely and snugly to prevent injury and possible death from falling off or tractor overturn. Personal Protective Equipment such as Hard Hat, Safety Glasses, Safety Shoes, and Ear Plugs are Recommended.

4. Block up or support raised machine and all lifted components securely before putting hands or feet under or working underneath any lifted components to prevent crushing injury or death from sudden dropping or inadvertent operation of controls. Make certain area is clear before lowering or folding.

5. Before transporting, put Lift Lever in detent or full-lift position. Secure the implement for transport by installing Cylinder Stops or Transport Pin on Pull-type implement center axle and Wing Transport Locks on folding implements.  
 • Attach Safety Chain to cutter and towing unit securely. See Operator's Manual.

6. Make certain that the SMV sign, Warning Lights, and Reflectors are clearly visible. Follow local traffic codes.

7. Never operate with Cutting Head raised if passerby, bystanders, or traffic are in the area to reduce possibility of injury or death from Objects thrown by Blades under Guard or cutter structure.

8. Before dismounting, secure implement in transport position or lower to ground.  
 • Put tractor in park or set the brake, disengage PTO, stop engine, and remove key, and wait until noise of rotation has ceased to prevent entanglement in rotating parts which can cause injury or death.  
 • Never mount or dismount a moving vehicle. Crushing from runover may cause injury or death.

<p><b>5. TRANSPORT SAFELY, LOCK UP.</b></p>	<p><b>6. USE SMV LIGHTS, &amp; REFLECTORS.</b></p>	<p><b>7. DO NOT OPERATE WITH CUTTER OR WING RAISED.</b></p>	<p><b>8. DO NOT MOUNT OR DISMOUNT WHILE MOVING.</b></p>
---	--	---	---

00749117

## WARRANTY INFORMATION:

Read and understand the complete Warranty Statement found in this Manual. Fill out the Warranty Registration Form in full and return it to within 30 Days. Make certain the Serial Number of the Machine is recorded on the Warranty Card and on the Warranty Form that you retain.



# PARTS ORDERING GUIDE

The following instructions are offered to help eliminate needless delay and error in processing purchase orders for the equipment in this section.

1. The Parts Section is prepared in logical sequence and grouping of parts that belong to the basic machine featured in this manual. Part Numbers and Descriptions are given to help locate the parts and quantities required.
2. The Purchase Order must include the name and address of the person or organization ordering the parts, who should be charged, and if possible, the serial number of the machine for which the parts are ordered.
3. The Purchase Order must clearly list the quantity of each part, the complete and correct part number (be sure to include all periods), and the basic name of the part.
4. The Manufacturer reserves the right to substitute parts where applicable.
5. Some parts are unlisted items which are special production items not normally stocked and are subject to special handling. Request a quotation for such parts before sending a Purchase Order.
6. The Manufacturer reserves the right to change prices without prior notice.

**NOTE:** Please refer to The Safety Section in the front of this Manual for the proper Part Number when ordering Replacement Safety Decals.



For maximum safety and to guarantee optimum product reliability, always use genuine Servis-Rhino Parts. The use of inferior replacement parts may cause premature or catastrophic failure which could result in serious injury or death. Direct any questions regarding parts to:



**ALAMO INDUSTRIAL**

1502 E. Walnut  
Seguin, Texas 78155  
830-379-1480



# **PARTS SECTION**





# PART NAME INDEX

CABLE ASY .....	5
CHAIN IDLER ASY .....	9
DRIVELINE ASY - P/N 00784015 - (OPTIONAL 1-3/8 X 21 SPLINE PTO) .....	14
DRIVELINE ASY - P/N 00784016 - (OPTIONAL 1-3/4 X 20 SPLINE PTO) .....	15
FAN DRIVE ASY .....	6
HITCH - CAT II & III QUICK HITCH ASY - (OPTIONAL) .....	12
HITCH - CAT II & III W/O QUICK HITCH ASY - (STANDARD) .....	11
HITCH - CAT II THREE POINT HITCH ASY - (STANDARD).....	10
HYDRAULIC CYLINDER & HOSE KIT (OPTIONAL).....	13
INTERNAL DRIVE ASY.....	8
OIL TANK PARTS .....	7
SPOUT ASY .....	4

# SPOUT ASY

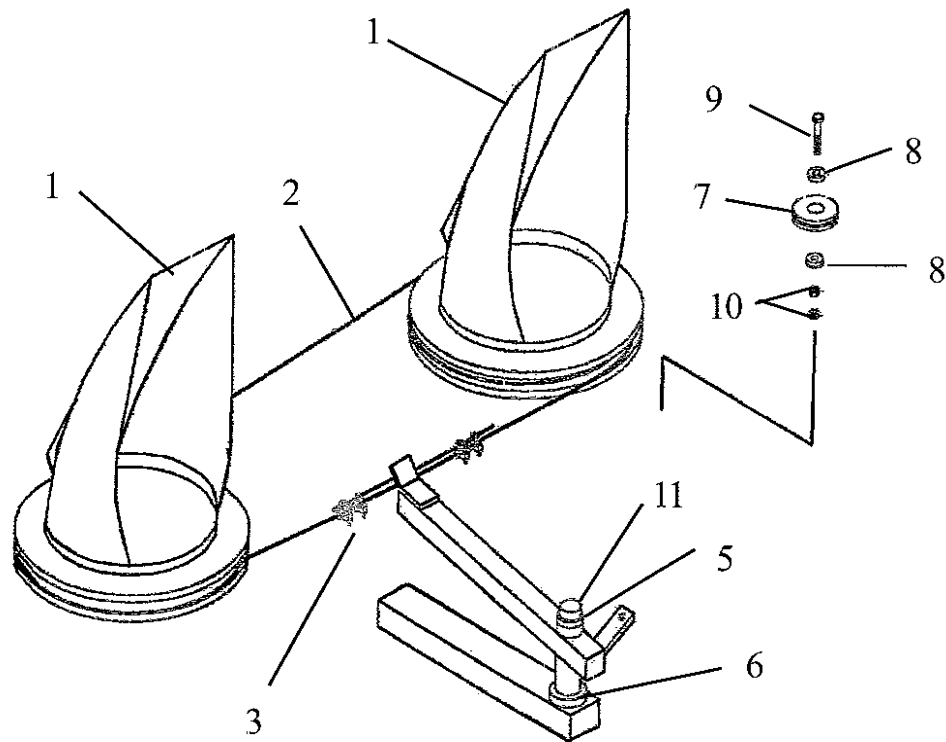

ITEM	PART NO.	QTY.	DESCRIPTION
1	00784020	2	SPOUT
2	00992000	35 1/2	CABLE, 1/4 X35 - 1/2 FT
3	60042	6	WIRE ROPE CLAMP 1/4
5	00783408	1	UPPER BUSHING
6	00783590	1	LOWER BUSHING
7	00783104	16	SPOUT HOLD DOWN W/ BEARINGS
8	00783874	32	HOLD DOWN BEARING
9	02845600	16	BOLT, 5/8 NC X 3 PL5
10	33007C	32	HEX NUT 5/8-11
11	3919A3C	1	AL HD CP PT STSCRW 5/16 -18 X 3/8

# CABLE ASY

Attach 1/4" cable clamp  
to center wrap and bolt to  
spout ring.

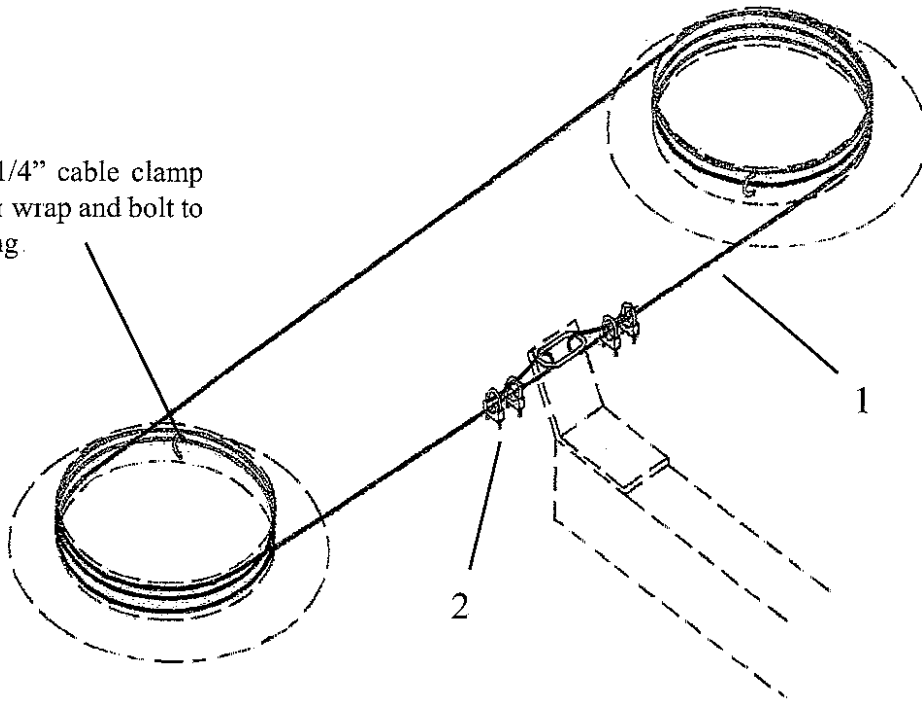

ITEM	PART NO.	QTY.	DESCRIPTION
1	00992000	35 1/2'	CABLE, 1/4 X 35 -1/2FT
2	60042	6	WIRE ROPE CLAMP 1/4

# FAN DRIVE ASY

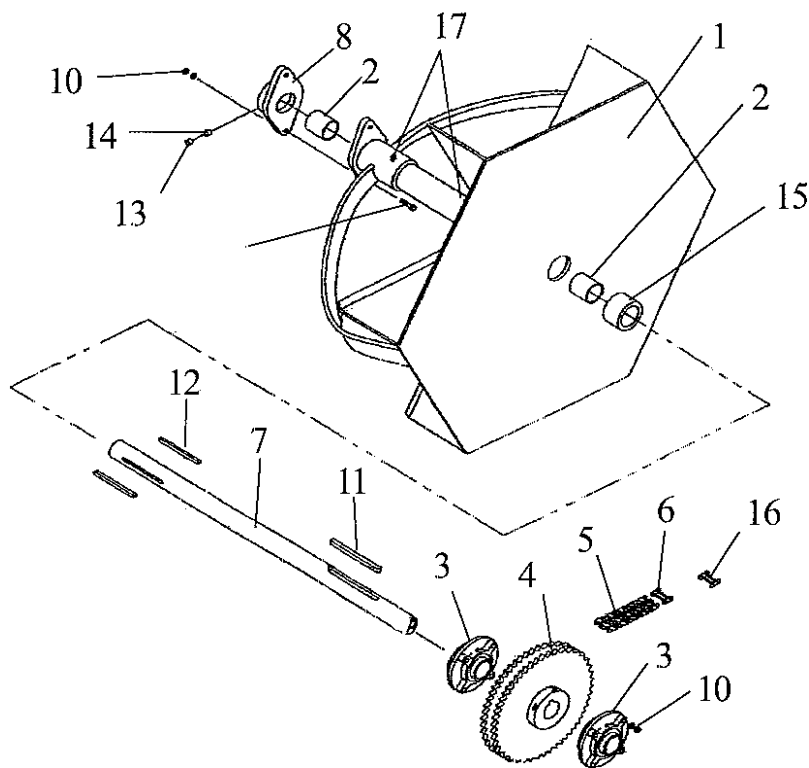

ITEM	PART NO.	QTY.	DESCRIPTION
1	00784078	2	FAN -CW
2	00784248	4	BUSHING, BRASS
3	00783604	5	BEARING 2- 7/16"
4	00783727	2	SPROCKET 54 TOOTH
5	00783738	2	ROLLER CHAIN 80 - 2 X 120 P
6	00783740	2	CONNECTOR LINK 80-2
7	00783416	2	FAN SHAFT
8	00784037	2	FRONT SHEAR PLATE
9	00783436	2	SHEAR BOLT
10	00001200	4	NUT 1/2 NC
11	40663.5	2	5/8" X 5/8" X 3-1/2" KEY
12	40652.25	4	1/2" X 1/2" X 2-1/4" KEY
13	3923A5C	2	5/8" X 1" SET SCREW
14	3923A1C	2	5/8" X 1/2" SET SCREW
15	00784256	2	FAN SPACER
16	00783742	2	OFFSET LINK, 80-2
17	00003500	4	GREASE FITTING 1/8 STRAIGHT

# OIL TANK PARTS

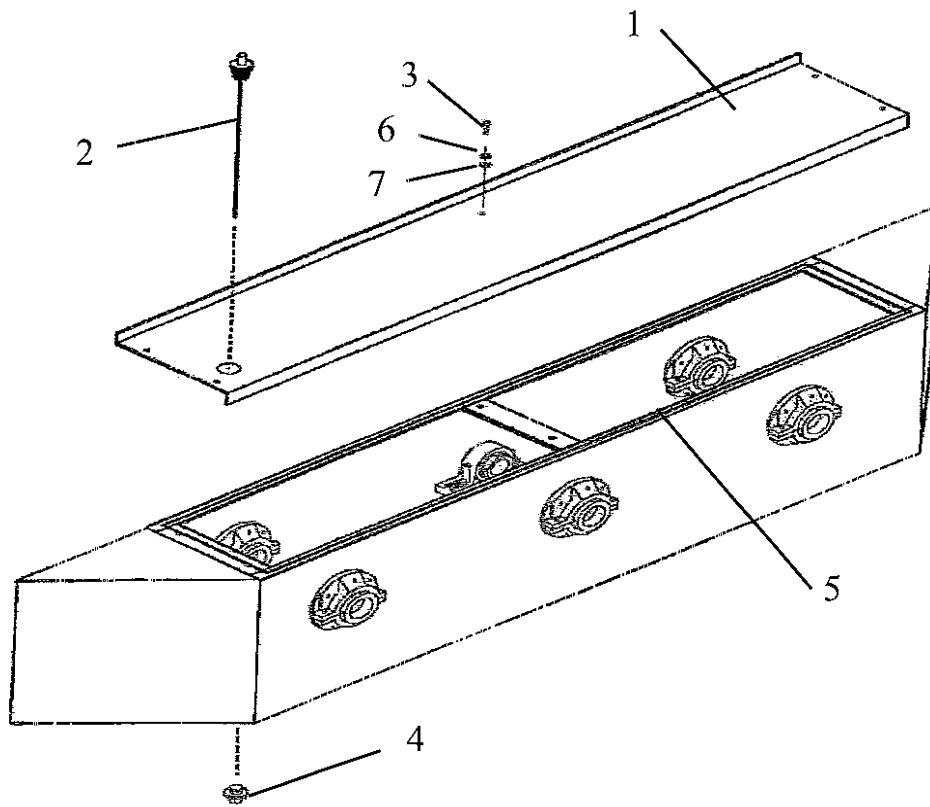

ITEM	PART NO.	QTY.	DESCRIPTION
1	00784104	1	COVER, CHAIN CASE
2	00783551	1	DIPSTICK
3	00011400	6	HHCS 3/8 NC 1 PL5
4	00784028	1	1" MAGNETIC DRAIN PLUG
5	00783692	14'	SEALER, FOAM
6	03101646	6	LOCKWASHER, 3/8,
7	00011100	6	FLATWASHER, 3/8

# INTERNAL DRIVE ASY

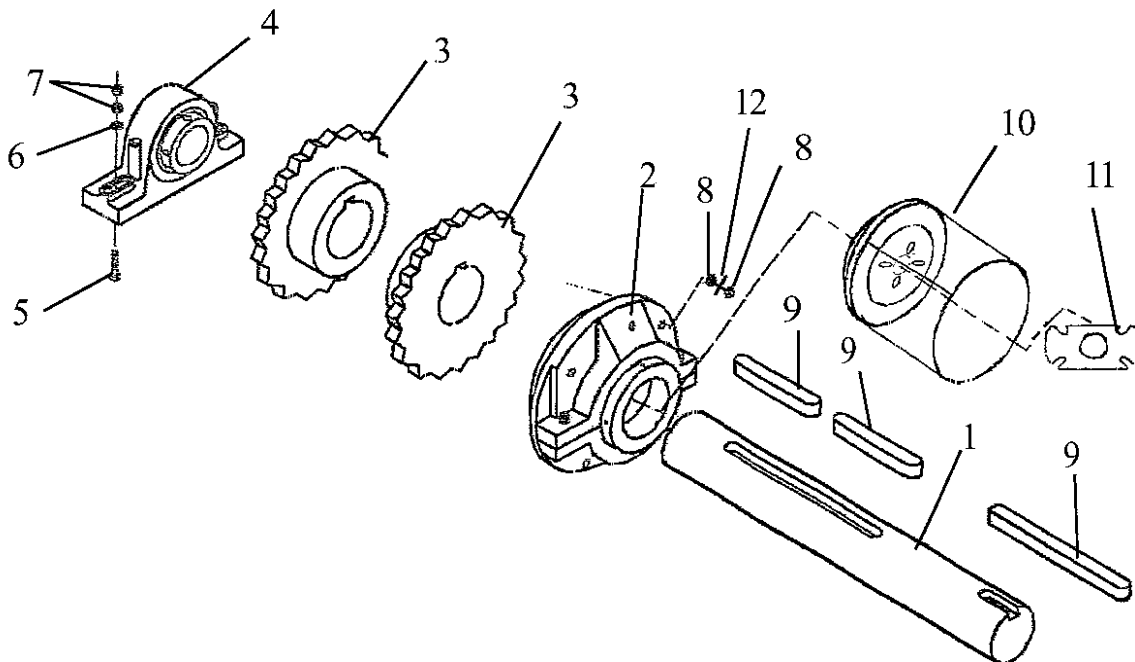

ITEM	PART NO.	QTY.	DESCRIPTION
1	00783435	1	DRIVE SHAFT
2	00783604	5	FLANGE BEARING 2-7/16"
3	00783726	2	SPROCKET X 19 TOOTH
4	00783602	1	PILLOW BLOCK BEARING, 2-7/16"
5	00750952	2	HEXB,5/8NC X 2-1/2,ZP,GRD5
6	00001400	2	FLATWASHER 5/8 PL STD
7	33007C	4	HEX NUT 5/8-11
8	00001200	8	NUT,HEX 1/2 NC PL
9	40662.75	2	KEY, 5/8 X 5/8 X 2-3/4
10	00784566	1	SHIELD, SAFETY DRIVE
11	00784565	1	PLATE, REINFORCEMENT
12	00002700	4	FLATWASHER 1/2 PL
13	00758785	1	KEY,1/2 X 1/2 X 2

# CHAIN IDLER ASY

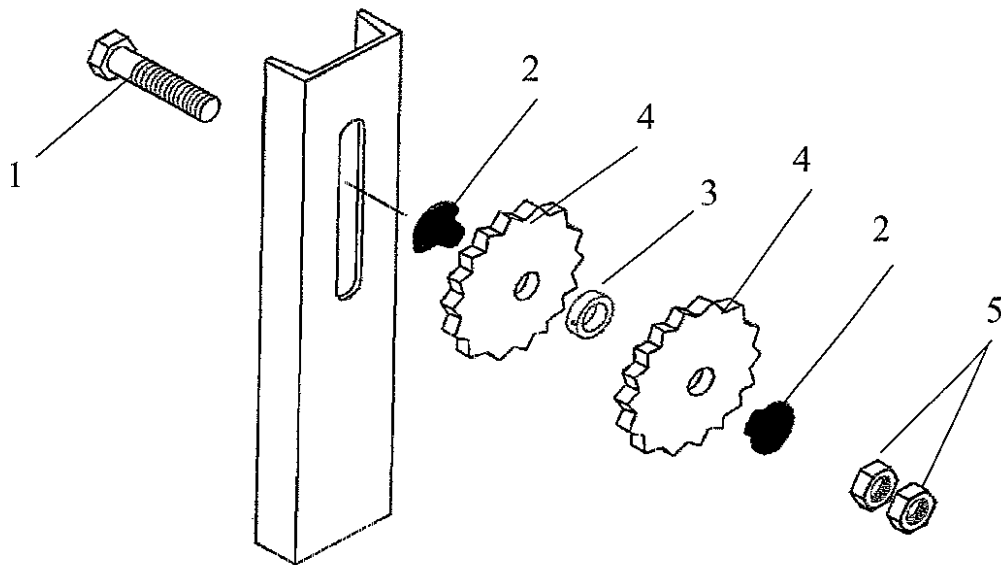

ITEM	PART NO.	QTY.	DESCRIPTION
1	00748598	2	BOLT, 3/4 NC X 5-1/2 PL5
2	00783477	4	SPACER
3	6D5557	2	SET COLLAR, 3/4"
4	1436356	4	IDLER SPROCKET
5	00000200	4	NUT, HEX 3/4"-NC PL

# HITCH - CAT II THREE POINT HITCH ASY - (STANDARD)

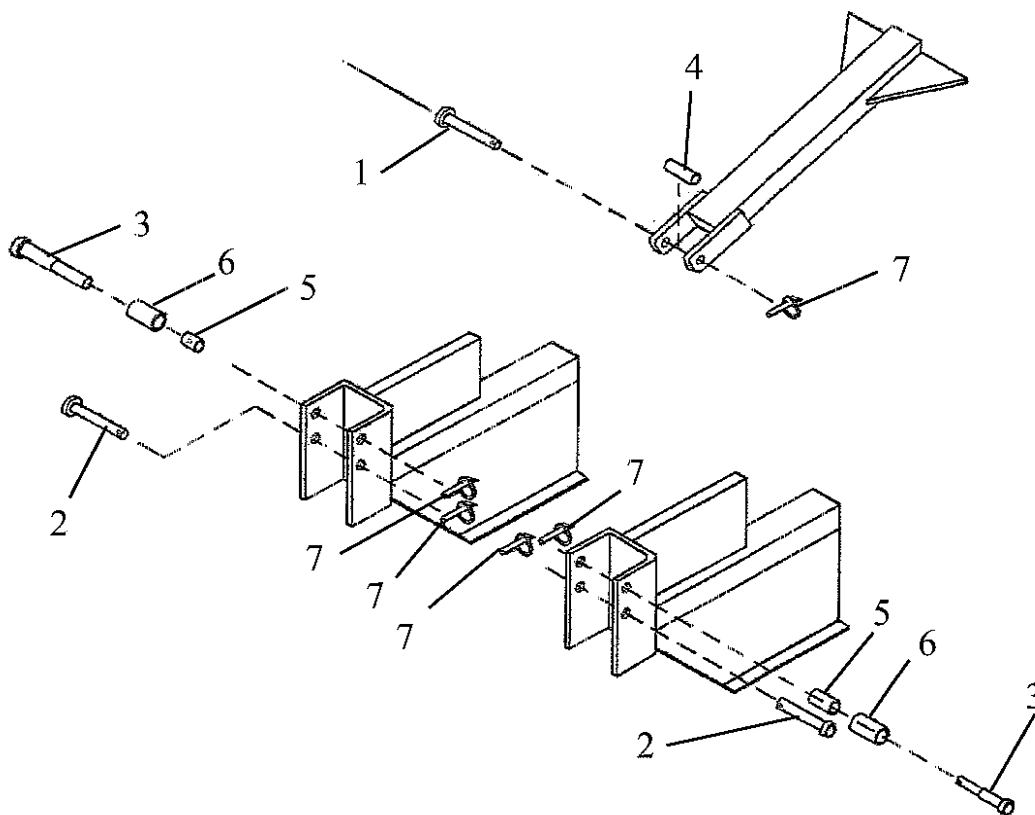

ITEM	PART NO.	QTY.	DESCRIPTION
1	00784030	1	UPPER 3PT HITCH PIN
2	00784031	2	LOWER CAT III HITCH PIN
3	00784032	2	LOWER CAT II HITCH PIN
4	00784033	1	BUSHING, UPPER HITCH PIN
5	00784034	2	BUSHING, LOWER INNER HITCH PIN
6	00784035	2	BUSHING, LOWER OUTER HITCH PIN
7	0838404	5	KLICK PIN 7/16 X 2



# HITCH - CAT II & III W/O QUICK HITCH ASY - (STANDARD)

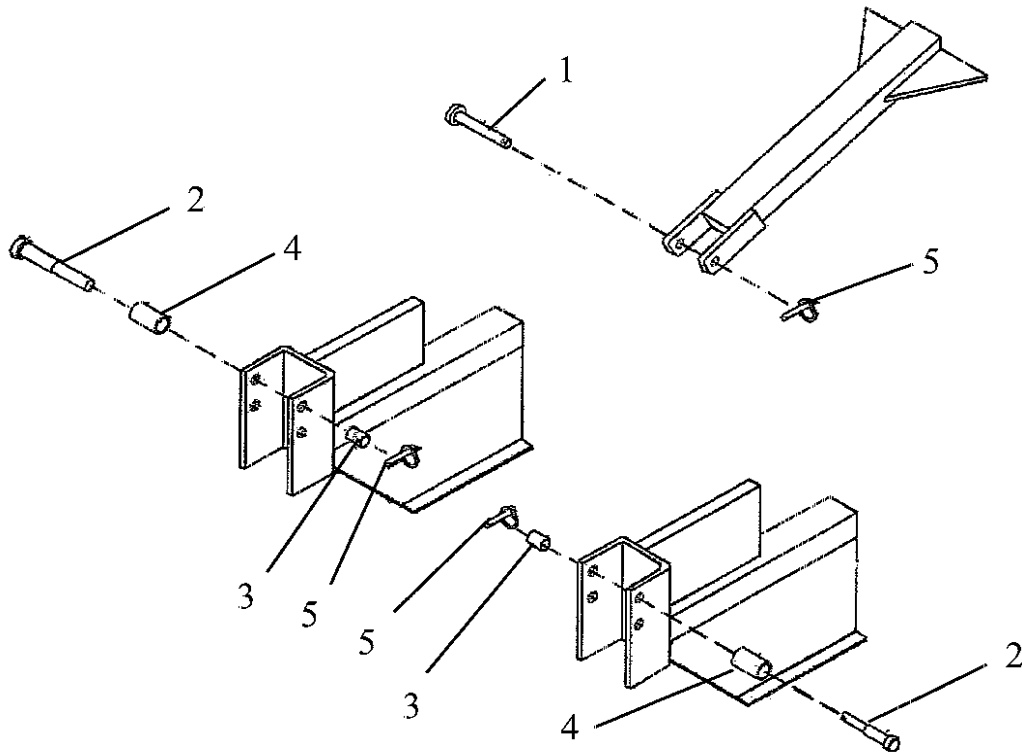

ITEM	PART NO.	QTY.	DESCRIPTION
1	00784030	1	UPPER 3PT HITCH PIN
2	00784032	2	LOWER CAT II HITCH PIN
3	00784034	2	BUSHING, LOWER INNER HITCH PIN
4	00784035	2	BUSHING, LOWER OUTER HITCH PIN
5	0838404	3	CLICK PIN 7/16 X 2

# HITCH - CAT II & III QUICK HITCH ASY - (OPTIONAL)

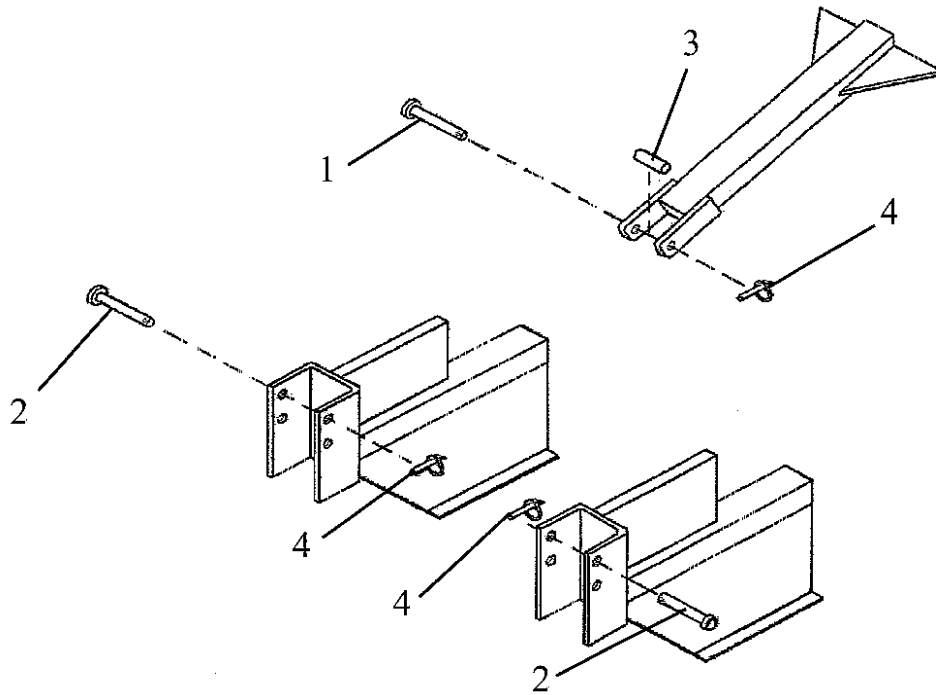

ITEM	PART NO.	QTY.	DESCRIPTION
1	00784030	1	UPPER 3PT HITCH PIN
2	00784031	2	LOWER CAT III HITCH PIN
3	00784033	1	BUSHING, UPPER HITCH PIN
4	0838404	3	CLICK PIN 7/16 X 2

# HYDRAULIC CYLINDER & HOSE KIT (OPTIONAL)

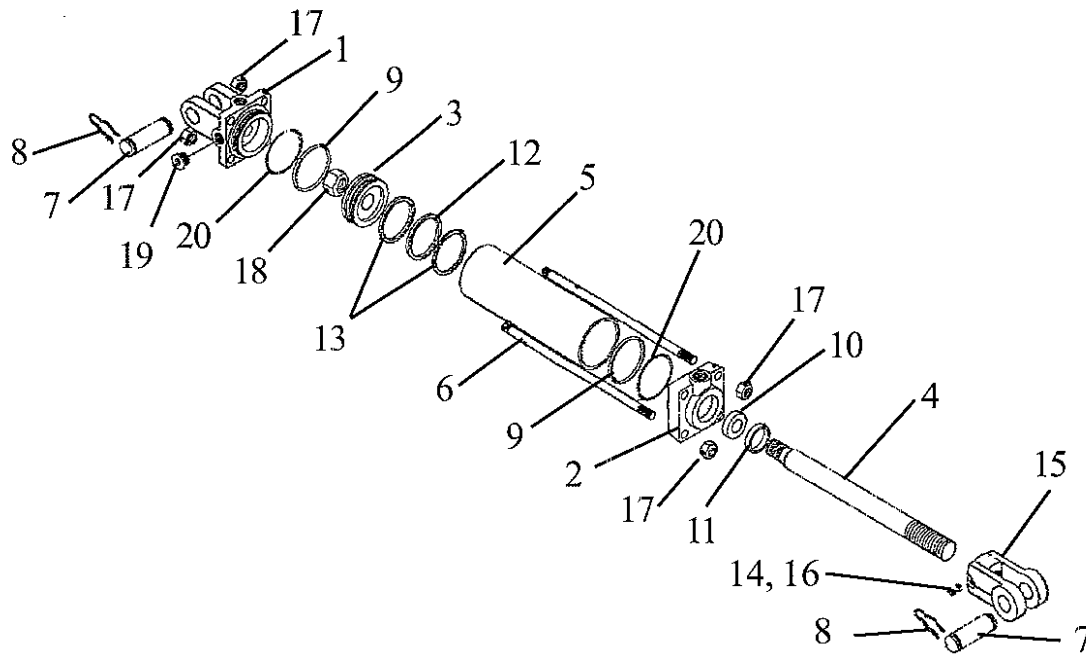

ITEM	PART NO.	QTY.	DESCRIPTION
	<b>00784087</b>	--	<b>CYLINDER &amp; HOSE KIT ASY</b>
	<b>2457104</b>	<b>1</b>	<b>CYLINDER ASY W/O HOSE KIT</b>
1	2417158	1	CAP, CYLINDER CLEVIS
2	2417157	1	CAP, CYLINDER ROD
3	2417160	1	PISTON, CYLINDER
4	00774737	1	ROD CYL 1.25-08-1.00-1.25-A
5	00774748	1	TUBE CYL 3.00-08.00
6	00774742	4	TIE ROD 1/2-08
7	3047104	2	PIN, 1
8	492110	4	HAIRPIN CLIP 7/8
9	-----	4	END CAP O-RING, (INCLUDED IN ITEM 24)
10	-----	1	SEAL, ROD WIPER, (INCLUDED IN ITEM 24)
11	-----	1	SEAL, ROD DUST, (INCLUDED IN ITEM 24)
12	-----	1	END CAP BACK-UP WASHERS, (INCLUDED IN ITEM 24)
13	-----	1	SEAL, PISTON SEAL, (INCLUDED IN ITEM 24)
14	-----	2	PISTON WEAR RING, (INCLUDED IN ITEM 24)
15	3047117	1	THREAD LOCK
16	1917140	1	ROD CLEVIS
17	0116000	1	SETECREW, SOCKET HEAD 3/8"-NC X 1/2"
18	33005H5C	8	NUT, HEX 1/2-13UNC GR5 PLT
19	5JRC12160	1	LOCKNUT, TOPLOCK 3/4"-NF PLC
20	1917132	1	PLUG, SOCKET HEAD O-RNG BOSS,3/4-16 UNF
21	1937156	1	ELBOW 90 DEG W/ RESTRICTOR
22	03200588	1	ADAPTER, HYD ELBOW
23	00784528	2	HOSE ASY, #6 X 120" LG
24	02975530	1	SEAL KIT (INCLUDES ITEMS 9,10,11,12,13,14)

# DRIVELINE ASY - P/N 00784015 - (OPTIONAL 1-3/8 X 21 SPLINE PTO)

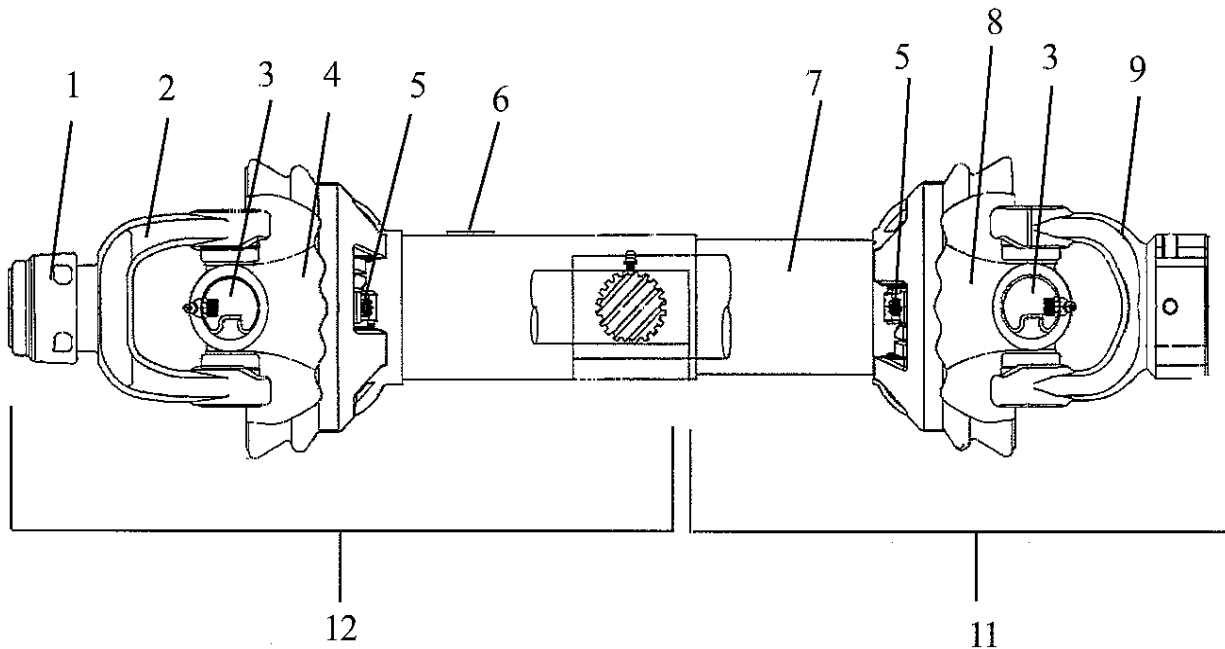

ITEM	PART NO.	QTY.	DESCRIPTION
	<b>00784015</b>	--	<b>DRIVELINE ASY, WITH SHIELDS 1-3/8" X 21 SPLINE PTO</b>
1	2716820	1	REPAIR KIT-SAFETY SLIDE LOCK Y
2	0136416	1	SLIDE LOCK YOKE-1 3/8-21 SPL,5
3	W507	2	UNIVERSAL JOINT (X-KIT)
4	00784049	1	YOKE & SHAFT
5	00780376	2	NYLON BEARING & KEEPER
6	00756005	1	DECAL, ROTATING DRIVELINE
7	00756004	1	DECAL, SHIELD MISSING
8	00784050	1	YOKE, TUBE & SLEEVE WELDMENT
9	00784051	1	YOKE, IMPLEMENT END
10	00784046	1	SHIELD ASY, COMPLETE INNER & OUTER
11	00784047	1	DRIVELINE HALF ASY, WITH SHIELD - TUBE (IMPLEMENT) END)
12	00784048	1	DRIVELINE HALF ASY, WITH SHIELD - SHAFT (TRACTOR) END

# DRIVELINE ASY - P/N 00784016 - (OPTIONAL 1-3/4 X 20 SPLINE PTO)

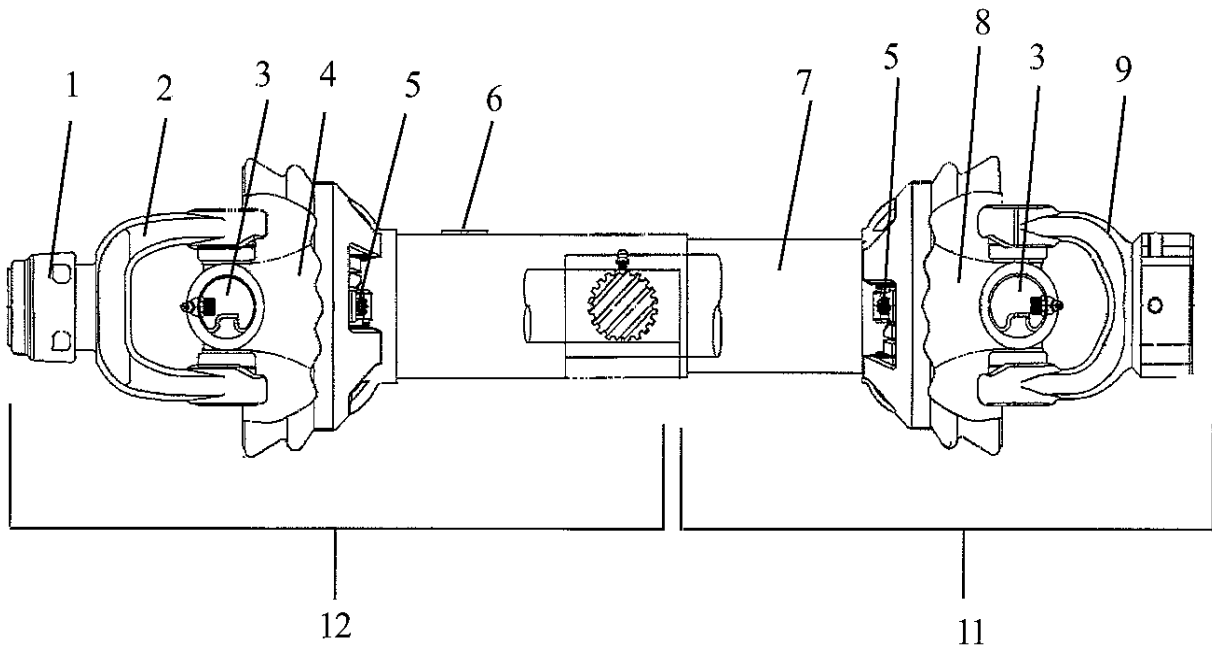

ITEM	PART NO.	QTY.	DESCRIPTION
	<b>00784016</b>	--	<b>DRIVELINE ASY, WITH SHIELDS (1-3/4" X 20 SPLINE PTO)</b>
1	00724738	1	SLIDE COLLAR REPAIR KIT
2	00725126	1	YOKE, Q.D. 1-3/4-20 SPL.
3	W507	2	UNIVERSAL JOINT (X-KIT)
4	00784049	1	YOKE & SHAFT WELDMENT
5	00780376	2	NYLON BEARING & KEEPER
6	00756005	1	DECAL, ROTATING DRIVELINE
7	00756004	1	DECAL, SHIELD MISSING
8	00784050	1	YOKE, TUBE & SLEEVE WELDMENT
9	00784051	1	YOKE, IMPLEMENT END
10	00784046	1	SHIELD ASY, COMPLETE INNER & OUTER
11	00784047	1	DRIVELINE HALF ASY, W/ SHIELD - TUBE (IMPLEMENT) END
12	00784052	1	DRIVELINE HALF ASY, W/ SHIELD - SHAFT (TRACTOR) END



# Alamo Industrial

## LIMITED WARRANTY

### 1. LIMITED WARRANTIES

- 1.01. Servis-Rhino warrants for one year from the purchase date to the original non-commercial, governmental, or municipal purchaser ("Purchaser") and warrants for six months to the original commercial or industrial purchaser ("Purchaser") that the goods purchased are free from defects in material or workmanship.
- 1.02. Manufacturer will replace for the Purchaser any part or parts found, upon examination at one of its factories, to be defective under normal use and service due to defects in material or workmanship.
- 1.03. This limited warranty does not apply to any part of the goods which has been subjected to improper or abnormal use, negligence, alteration, modification, or accident, damaged due to lack of maintenance or use of wrong fuel, oil, or lubricants, or which has served its normal life. This limited warranty does not apply to any part of any internal combustion engine, or expendable items such as blades, shields, guards, or pneumatic tires except as specifically found in your Operator's Manual.
- 1.04. Except as provided herein, no employee, agent, Dealer, or other person is authorized to give any warranties of any nature on behalf of Manufacturer.

### 2. REMEDIES AND PROCEDURES.

- 2.01. This limited warranty is not effective unless the Purchaser returns the Registration and Warranty Form to Manufacturer within 30 days of purchase.
- 2.02. Purchaser claims must be made in writing to the Authorized Dealer ("Dealer") from whom Purchaser purchased the goods or an approved Authorized Dealer ("Dealer") within 30 days after Purchaser learns of the facts on which the claim is based.
- 2.03. Purchaser is responsible for returning the goods in question to the Dealer.
- 2.04. If after examining the goods and/or parts in question, Manufacturer finds them to be defective under normal use and service due to defects in material or workmanship, Manufacturer will:
  - (a) Repair or replace the defective goods or part(s) or
  - (b) Reimburse Purchaser for the cost of the part(s) and reasonable labor charges (as determined by Manufacturer) if Purchaser paid for the repair and/or replacement prior to the final determination of applicability of the warranty by Manufacturer.The choice of remedy shall belong to Manufacturer.
- 2.05. Purchaser is responsible for any labor charges exceeding a reasonable amount as determined by Manufacturer and for returning the goods to the Dealer, whether or not the claim is approved. Purchaser is responsible for the transportation cost for the goods or part(s) from the Dealer to the designated factory.

### 3. LIMITATION OF LIABILITY.

- 3.01. MANUFACTURER DISCLAIMS ANY EXPRESS (EXCEPT AS SET FORTH HEREIN) AND IMPLIED WARRANTIES WITH RESPECT TO THE GOODS INCLUDING, BUT NOT LIMITED TO, MERCHANTABILITY AND FITNESS FOR A PARTICULAR PURPOSE.
- 3.02. MANUFACTURER MAKES NO WARRANTY AS TO THE DESIGN, CAPABILITY, CAPACITY, OR SUITABILITY FOR USE OF THE GOODS.
- 3.03. EXCEPT AS PROVIDED HEREIN, MANUFACTURER SHALL HAVE NO LIABILITY OR RESPONSIBILITY TO PURCHASER OR ANY OTHER PERSON OR ENTITY WITH RESPECT TO ANY LIABILITY, LOSS, OR DAMAGE CAUSED OR ALLEGED TO BE CAUSED DIRECTLY OR INDIRECTLY BY THE GOODS INCLUDING, BUT NOT LIMITED TO, ANY INDIRECT, SPECIAL, CONSEQUENTIAL, OR INCIDENTAL DAMAGES RESULTING FROM THE USE OR OPERATION OF THE GOODS OR ANY BREACH OF THIS WARRANTY. NOTWITHSTANDING THE ABOVE LIMITATIONS AND WARRANTIES, MANUFACTURER'S LIABILITY HEREUNDER FOR DAMAGES INCURRED BY PURCHASER OR OTHERS SHALL NOT EXCEED THE PRICE OF THE GOODS.
- 3.04. NO ACTION ARISING OUT OF ANY CLAIMED BREACH OF THIS WARRANTY OR TRANSACTIONS UNDER THIS WARRANTY MAY BE BROUGHT MORE THAN TWO (2) YEARS AFTER THE CAUSE OF ACTION HAS OCCURRED.

### 4. MISCELLANEOUS.

- 4.01. Proper Venue for any lawsuits arising from or related to this limited warranty shall be only in Guadalupe County, Texas.
- 4.02. Manufacturer may waive compliance with any of the terms of this limited warranty, but no waiver of any terms shall be deemed to be a waiver of any other term.
- 4.03. If any provision of this limited warranty shall violate any applicable law and is held to be unenforceable, then the invalidity of such provision shall not invalidate any other provisions herein.
- 4.04. Applicable law may provide rights and benefits to purchaser in addition to those provided herein.

### KEEP FOR YOUR RECORDS

ATTENTION: Purchaser should fill in the blanks below for his reference when buying repair parts and/or for proper machine identification when applying for warranty.

Servis-Rhino Implement Model \_\_\_\_\_ Serial Number \_\_\_\_\_

Date Purchased \_\_\_\_\_ Dealer \_\_\_\_\_

ATTENTION:  
READ YOUR OPERATOR'S MANUAL





## TO THE OWNER/OPERATOR/DEALER

To keep your implement running efficiently and safely, read your manual thoroughly and follow these directions and the Safety Messages in this Manual. The Table of Contents clearly identifies each section where you can easily find the information you need.

The OCCUPATIONAL SAFETY AND HEALTH ACT (1928.51 Subpart C) makes these minimum safety requirements of tractor operators:

### REQUIRED OF THE OWNER:

1. Provide a Roll-Over-Protective Structure that meets the requirements of this Standard; and
2. Provide Seatbelts that meet the requirements of this paragraph of this Standard and SAE J4C; and
3. Ensure that each employee uses such Seatbelt while the tractor is moving; and
4. Ensure that each employee tightens the Seatbelt sufficiently to confine the employee to the protected area provided by the ROPS.

### REQUIRED OF THE OPERATOR

1. Securely fasten seatbelt if the tractor has a ROPS.
2. Where possible, avoid operating the tractor near ditches, embankments, and holes.
3. Reduce speed when turning, crossing slopes, and on rough, slick, or muddy surfaces.
4. Stay off slopes too steep for safe operation.
5. Watch where you are going - especially at row ends, on roads, and around trees.
6. Do not permit others to ride.
7. Operate the tractor smoothly - no jerky turns, starts, or stops.
8. Hitch only to the drawbar and hitch points recommended by the tractor manufacturer.
9. When the tractor is stopped, set brakes securely and use park lock, if available.



**Keep children away from danger all day, every day...**



**Equip tractors with rollover protection (ROPS) and keep all machinery guards in place...**



**Please work, drive, play and live each day with care and concern for your safety and that of your family and fellow citizens.**







G/W Snow Blower - 8650A - (08-05)

© 2005 Alamo Industrial