



GREAT WHITE 8600-AR

Snow Blower

Published 08-05

P/N 5043P

PART'S MANUAL

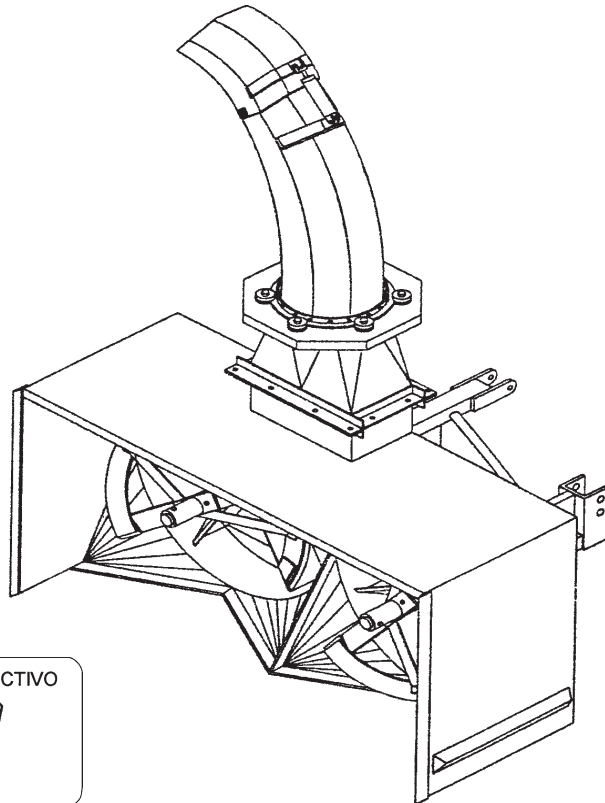

ATENCIÓN!

LEA EL INSTRUCTIVO

Si No Lee Ingles, Pida Ayuda a Alguien Que Si Lo Lea Para Que le Traduzca las Medidas de Seguridad.



An Operator's Manual was shipped with the equipment in the Manual Canister. This Operator's Manual is an integral part of the safe operation of this machine and must be maintained with the unit at all times. **READ, UNDERSTAND, and FOLLOW** the Safety and Operation Instructions contained in this manual before operating the equipment. If the Operator's Manual is not with the equipment, contact your dealer or Alamo Industrial (830-379-1480) to obtain a copy before operating the equipment.

ALAMO INDUSTRIAL

1502 E. Walnut
Seguin, Texas 78155
830-379-1480

© 2005 Alamo Industrial



TO THE OWNER/OPERATOR/DEALER

All implements with moving parts are potentially hazardous. There is no substitute for a cautious, safe-minded operator who recognizes the potential hazards and follows reasonable safety practices. The manufacturer has designed this implement to be used with all its safety equipment properly attached to minimize the chance of accidents.

BEFORE YOU START!! Read the safety messages on the implement and shown in your manual. Observe the rules of safety and common sense!

DANGER

FAILING TO FOLLOW SAFETY MESSAGES AND OPERATING INSTRUCTIONS CAN CAUSE SERIOUS BODILY INJURY OR EVEN DEATH TO OPERATOR AND OTHERS IN THE AREA.

<p>1.</p>	<p>2. NO RIDERS. NO CHILDREN OPERATORS.</p>	<p>3. USE SAFETY SHOES, HARD HAT, SAFETY GLASSES, SEAT BELTS, & ROPS</p>	<p>4. BLOCK UP SECURELY BEFORE WORKING UNDER.</p>
------------------	--	---	--

1. Study and understand operator's manual, safety signs, and Instructional decals for tractor and implement to prevent misuse, abuse, and accidents.

- Learn how to stop engine suddenly in an emergency. Be alert for passerby and especially children.

2. Allow no children on or near implement or tractor. Allow no riders on tractor and implement. Falling off may cause serious injury or death from being run over by tractor or cutter or contact with rotating blades.

3. Operate only with tractor having Roll-Over Protective Structure (ROPS) and with seatbelt fastened securely and snugly to prevent injury and possible death from falling off or tractor overturn. Personal Protective Equipment such as Hard Hat, Safety Glasses, Safety Shoes, and Ear Plugs are Recommended.

4. Block up or support raised machine and all lifted components securely before putting hands or feet under or working underneath any lifted components to prevent crushing injury or death from sudden dropping or inadvertent operation of controls. Make certain area is clear before lowering or folding.

5. Before transporting, put Lift Lever in detent or full-lift position. Secure the implement for transport by installing Cylinder Stops or Transport Pin on Pull-type implement center axle and Wing Transport Locks on folding implements.

- Attach Safety Chain to cutter and towing unit securely. See Operator's Manual.

6. Make certain that the SMV sign, Warning Lights, and Reflectors are clearly visible. Follow local traffic codes.

7. Never operate with Cutting Head raised if passerby, bystanders, or traffic are in the area to reduce possibility of injury or death from Objects thrown by Blades under Guard or cutter structure.

8. Before dismounting, secure implement in transport position or lower to ground.

- Put tractor in park or set the brake, disengage PTO, stop engine, and remove key, and wait until noise of rotation Has ceased to prevent entanglement in rotating parts which can cause injury or death.
- Never mount or dismount a moving vehicle. Crushing from runover may cause injury or death.

<p>5. TRANSPORT SAFELY, LOCK UP.</p>	<p>6. USE SMV LIGHTS, & REFLECTORS.</p>	<p>7. DO NOT OPERATE WITH CUTTER OR WING RAISED.</p>	<p>8. DO NOT MOUNT OR DISMOUNT WHILE MOVING.</p>
---	--	---	---

00749117

WARRANTY INFORMATION:

Read and understand the complete Warranty Statement found in this Manual. Fill out the Warranty Registration Form in full and return it to within 30 Days. Make certain the Serial Number of the Machine is recorded on the Warranty Card and on the Warranty Form that you retain.

PARTS ORDERING GUIDE

The following instructions are offered to help eliminate needless delay and error in processing purchase orders for the equipment in this section.

1. The Parts Section is prepared in logical sequence and grouping of parts that belong to the basic machine featured in this manual. Part Numbers and Descriptions are given to help locate the parts and quantities required.
2. The Purchase Order must include the name and address of the person or organization ordering the parts, who should be charged, and if possible, the serial number of the machine for which the parts are ordered.
3. The Purchase Order must clearly list the quantity of each part, the complete and correct part number (be sure to include all periods), and the basic name of the part.
4. The Manufacturer reserves the right to substitute parts where applicable.
5. Some parts are unlisted items which are special production items not normally stocked and are subject to special handling. Request a quotation for such parts before sending a Purchase Order.
6. The Manufacturer reserves the right to change prices without prior notice.

NOTE: Please refer to The Safety Section in the front of this Manual for the proper Part Number when ordering Replacement Safety Decals.



For maximum safety and to guarantee optimum product reliability, always use genuine Servis-Rhino Parts. The use of inferior replacement parts may cause premature or catastrophic failure which could result in serious injury or death. Direct any questions regarding parts to:



ALAMO INDUSTRIAL

1502 E. Walnut
Seguin, Texas 78155
830-379-1480



PART NAME INDEX

CHAIN IDLER DETAIL ASY	6
CHAIN TIGHTENER DETAIL ASY	7
DRIVELINE ASY - P/N 00784015 - (OPTIONAL 1-3/8 X 21 SPLINE)	8
DRIVELINE ASY - P/N 00784016 - (OPTIONAL 1-3/4 X 20 SPLINE)	9
FAN DRIVE ASY	5
HITCH - CAT. II & III QUICK HITCH ASY - (OPTIONAL)	13
HITCH - CAT. II & III W/O QUICK HITCH ASY - (STANDARD)	14
HITCH - CAT. II QUICK HITCH ASY - (OPTIONAL)	12
HITCH - CAT. II THREE POINT HITCH ASY - (STANDARD).....	11
HITCH - CAT. III W/O QUICK HITCH ASY - (STANDARD)	15
HYDRAULIC CYLINDER ASY - P/N 00783837	10
INPUT SHAFT DETAIL ASY	4
SPOUT ASY - (OPTIONAL)	16

INPUT SHAFT DETAIL ASY

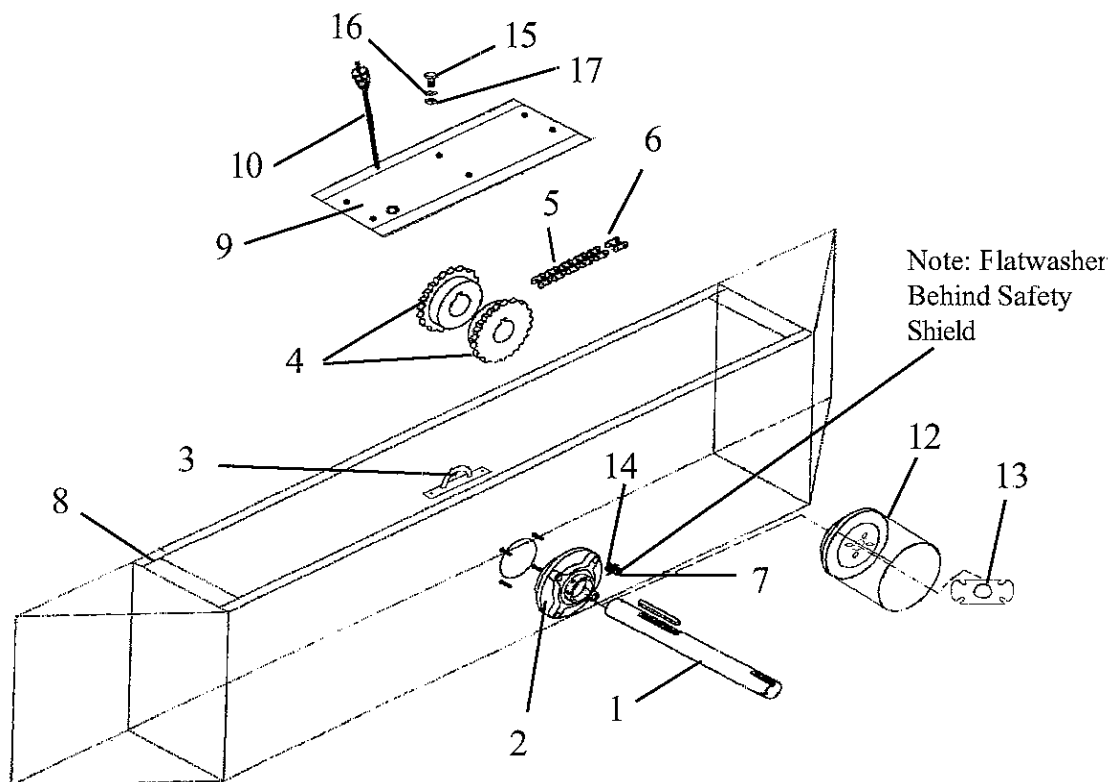

ITEM	PART NO.	QTY.	DESCRIPTION
1	00783061	1	INPUT SHAFT
2	00783596	1	1-15/16" FLANGE BEARING
3	00783598	1	1-15/16" PILLOW BLOCK BEARING
4	00783721	2	1-15/16" BORE SPROCKET X 16 TOOTH
5	00784660	1	80 ROLLER CHAIN # 80 X 135P
6	7D5118	1	80 CONNECTOR LINK, #80
7	00001200	8	NUT,HEX 1/2 NC PL
8	00783692	14'	SEALER, FOAM 3/8 X 1 1/4
9	00784104	1	CHAIN CASE COVER
10	00783551	1	DIPSTICK
12	00784566	1	SHIELD, SAFETY DRIVE
13	00784565	1	PLATE, REINFORCEMENT
14	00002700	4	FLATWASHER 1/2
15	00011400	6	HHCS 3/8 NC 1 PL5
16	03101646	6	LOCKWASHER,3/8
17	00011100	6	FLATWASHER, 3/8
18	00750952	2	BOLT,5/8NC X 2-1/2 PL5
19	00001400	2	FLATWASHER, 5/8
20	33007C	4	HEX NUT, 5/8 NC

FAN DRIVE ASY

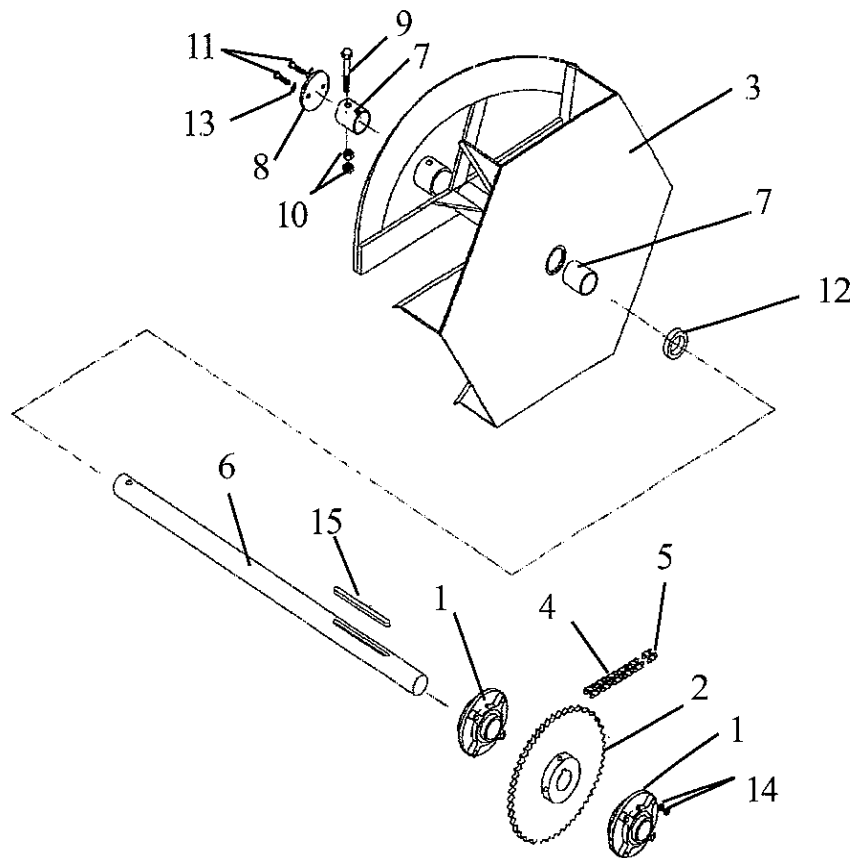

ITEM	PART NO.	QTY.	DESCRIPTION
1	00783595	4	FLANGE BEARING, 2 1/4"
2	00783723	2	SPROCKET, 54 TOOTH
3	00784144	1	FAN CW
	00784145	1	FAN CCW
4	00784618	1	ROLLER CHAIN, # 80 X 85 PITCHES
5	7D5118	1	CONNECTOR LINK, # 80
6	00783062	2	FAN SHAFT
7	00784247	4	BRASS BUSHING, 2-1/4 " ID
8	00783105	2	END CAP
9	00783578	2	SHEAR BOLT, 3/4 X 6
10	00000200	4	NUT 3/4" NC
11	00035900	4	BOLT 5/16"-NC X 3/4" PL5
12	00783693	2	UHMW FAN SPACER
13	00011700	4	LOCKWASHER 5/16 PL
14	00001200	16	NUT, HEX 1/2 NC PL
15	00725073	2	SQ KEY, 1/2 X 2-1/2

CHAIN IDLER DETAIL ASY

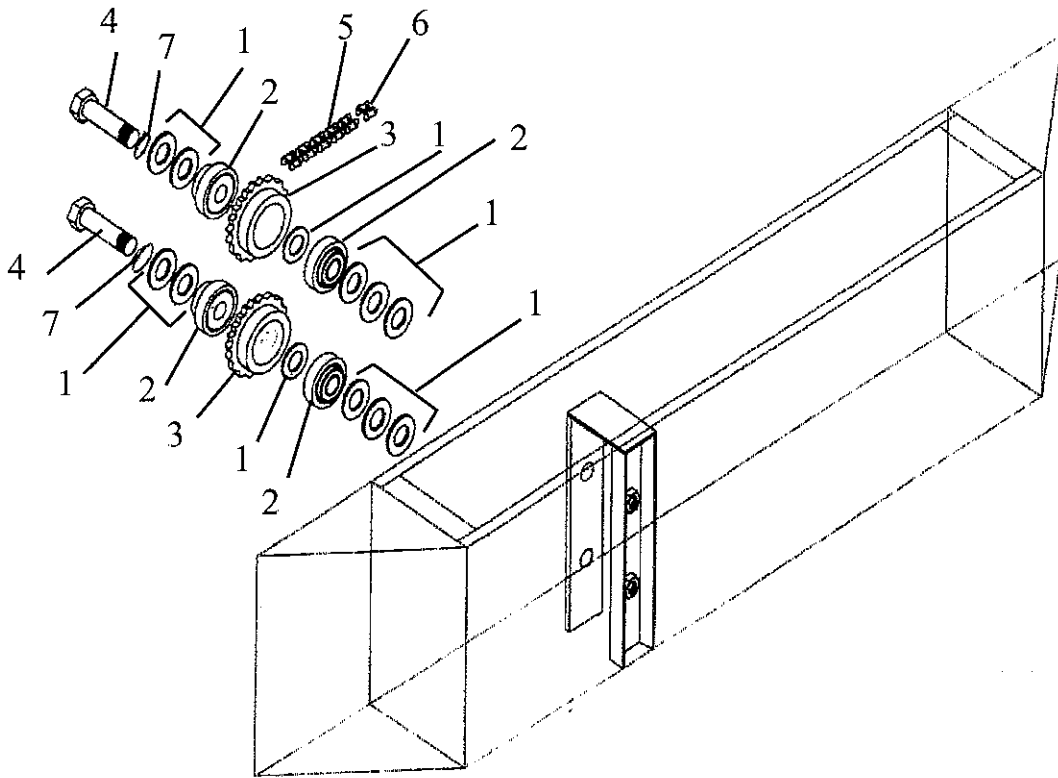

ITEM	PART NO.	QTY.	DESCRIPTION
1	44873	12	BUSHING MACHINERY
2	00783588	4	BEARING,INSERT FLAT - 1-1/2
4	00783311	2	SPROCKET, 18 TOOTH
5	00783312	2	BOLT, SPROCKET
6	00784660	1	ROLLER CHAIN, # 80 X 135P
7	7D5118	1	80 CONNECTOR LINK
9	350027C	2	LOCKWASHER 1 1/2

CHAIN TIGHTENER DETAIL ASY

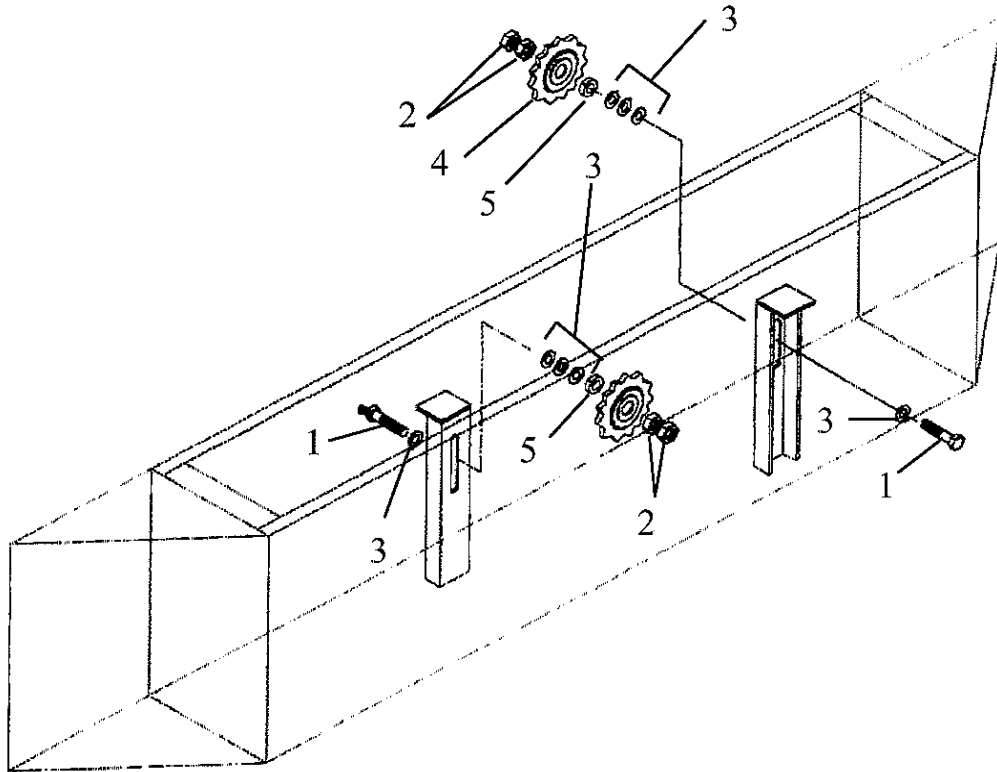

ITEM	PART NO.	QTY.	DESCRIPTION
1	00784038	2	CHAIN IDLER BOLT
2	00000200	4	HEX NUT 3/4 NC
3	00002701	8	FLATWASHER,3/4
4	1436356	2	IDLER SPROCKET
5	6D5557	2	LOCK COLLAR 3/4 BORE

DRIVELINE ASY - P/N 00784015 - (OPTIONAL 1-3/8 X 21 SPLINE)

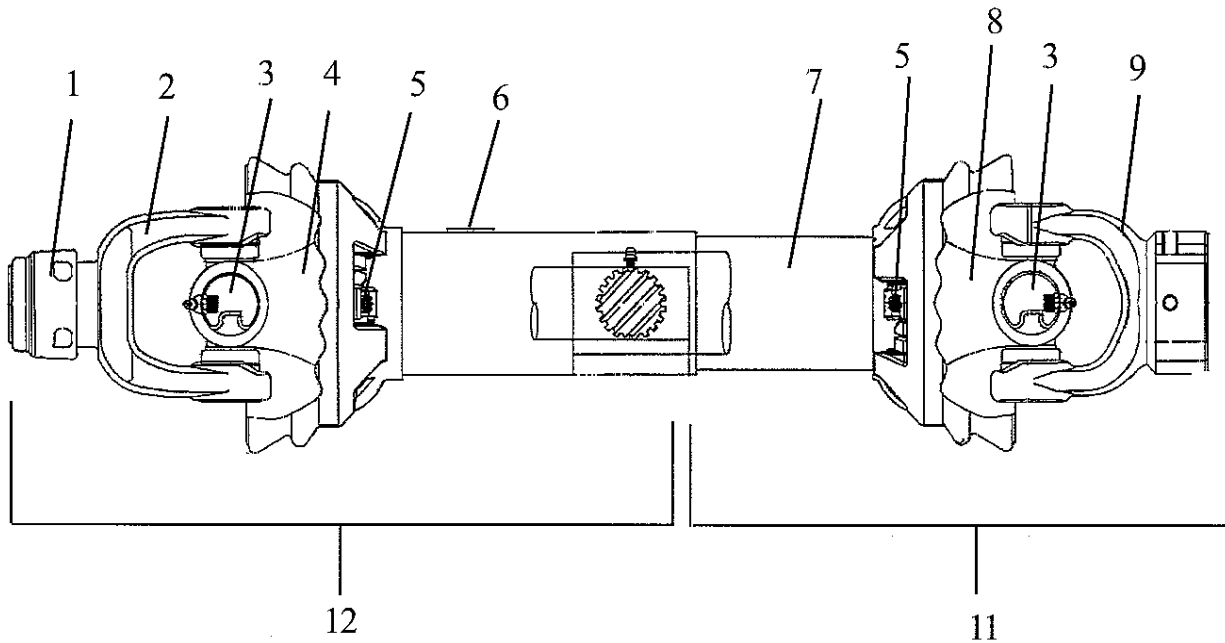

ITEM	PART NO.	QTY.	DESCRIPTION
	00784015	--	DRIVELINE ASY, W/ SHIELDS (F/ 1-3/8" X 21 SPLINE PTO)
1	2716820	1	SLIDE COLLAR REPAIR KIT
2	0136416	1	YOKE, Q.D. 1-3/8" X 21 SPL
3	W507	2	UNIVERSAL JOINT (X-KIT)
4	00784049	1	YOKE & SHAFT WELDMENT
5	00780376	2	NYLON BEARING & KEEPER
6	00756005	1	DECAL, ROTATING DRIVELINE
7	00756004	1	DECAL, SHIELD MISSING
8	00784050	1	YOKE, TUBE & SLEEVE WELDMENT
9	00784051	1	YOKE, IMPLEMENT END
10	00781046	1	SHIELD ASY, INNER & OUTER COMPLETE
11	00784047	1	DRIVELINE HALF ASY W/ SHIELD, TUBE (IMPLEMENT) END
12	00784048	1	DRIVELINE HALF ASY W/ SHIELD, SHAFT (TRACTOR) END

DRIVELINE ASY - P/N 00784016 - (OPTIONAL 1-3/4 X 20 SPLINE)

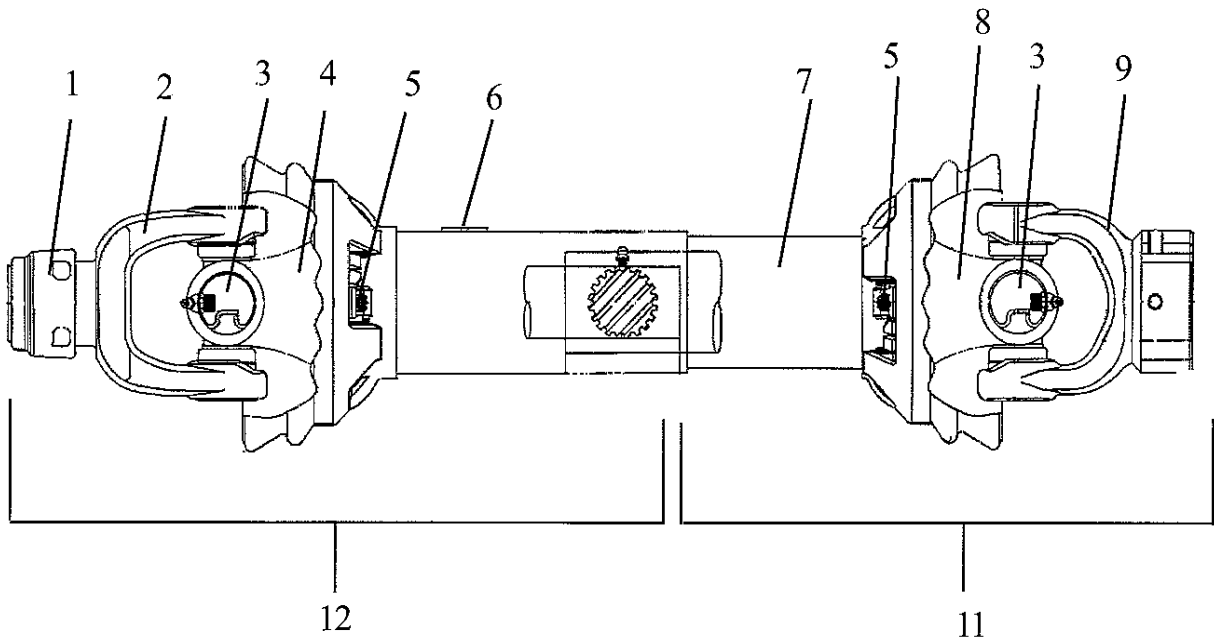

ITEM	PART NO.	QTY.	DESCRIPTION
	00784016	--	DRIVELINE ASY W/ SHIELD, (F/ 1-3/4" X 20 SPLINE PTO)
1	00724738	1	SLIDE COLLAR REPAIR KIT
2	00725126	1	YOKE, Q.D. 1-3/4" X 20 SPL.
3	W507	2	UNIVERSAL JOINT (X-KIT)
4	00784049	1	YOKE & SHAFT WELDMENT
5	00780376	2	NYLON BEARING & KEEPER
6	00756005	1	DECAL, ROTATING DRIVELINE
7	00756004	1	DECAL, SHIELD MISSING
8	00784050	1	YOKE, TUBE & SLEEVE WELDMENT
9	00784051	1	YOKE, IPLEMENT END
10	00784049	1	SHIELD ASY, COMPLETE INNER & OUTER ASY
11	00784047	1	DRIVELINE HALF ASY W/ SHIELD, TUBE (IMPLEMENT) END
12	00784052	1	DRIVELINE HALF ASY W/ SHIELD, SHAFT (TRACTOR) END

HYDRAULIC CYLINDER ASY - P/N 00783837

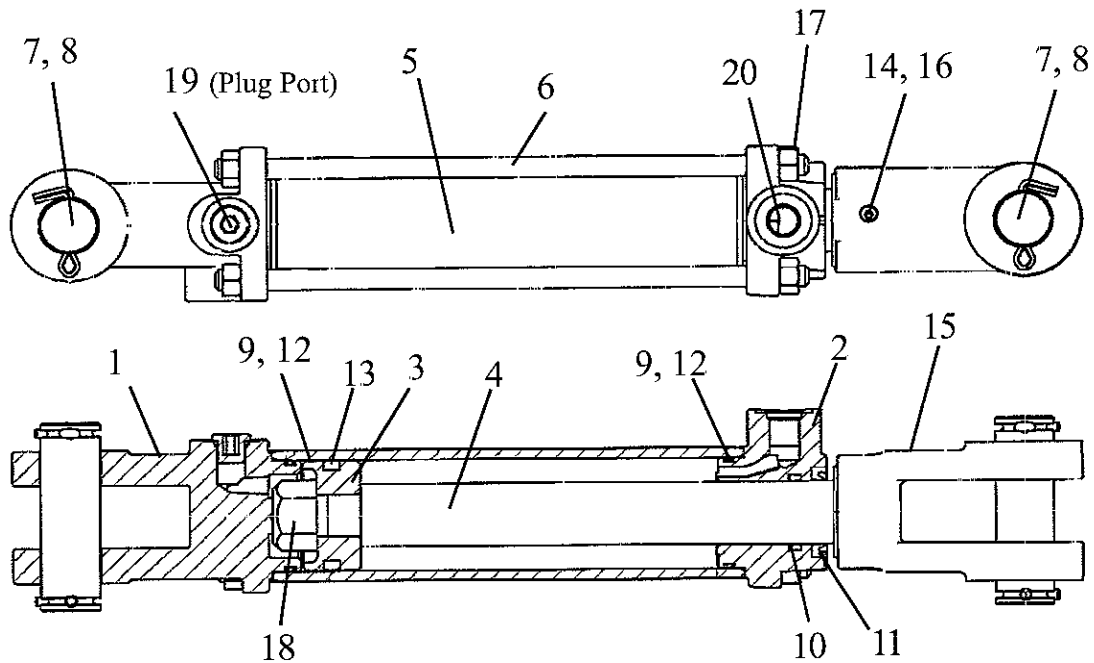

ITEM	PART NO.	QTY.	DESCRIPTION
	00773837	--	CYLINDER ASY
1	00784254	1	CLEVIS CAP
2	00784253	1	ROD CAP
3	1417141	1	PISTON,CYLINDER
4	00784255	1	ROD CYL
5	00784251	1	TUBE CYL
6	00784252	4	TIE ROD 3/8-06
7	3047104	2	PIN CYL
8	49045	2	COTTER PIN, 3/16" X 1-1/2" PLATED
9	-----	2	O-RING (INCLUDED IN ITEM 21)
10	-----	1	SEAL (INCLUDED IN ITEM 21)
11	-----	2	SEAL (INCLUDED IN ITEM 21)
12	-----	1	SEAL WIPER ROD (INCLUDED IN ITEM 21)
13	-----	1	SEAL PSP PISTON RING (INCLUDED IN ITEM 21)
14	3047117	1	THREAD LOCK
15	3047119	1	ROD CLEVIS
16	0116000	1	SETSCREW, SOCKET HEAD 3/8"-NC 1/2"
17	33003H5C	8	HEX NUT, 3/8-16 GR5
18	5JRC12160	1	LOCKNUT, TOPLOCK 3/4"-NF PLC
19	00784250	1	PLUG 9/16-18UNF SOC HD STR
20	00784249	2	THREAD PROTECTOR, 9/16" INT PLSTC
21	00768668	1	SEAL KIT, (INCLUDES ITEMS 9,10,11,12 & 13)

HITCH - CAT. II THREE POINT HITCH ASY - (STANDARD)

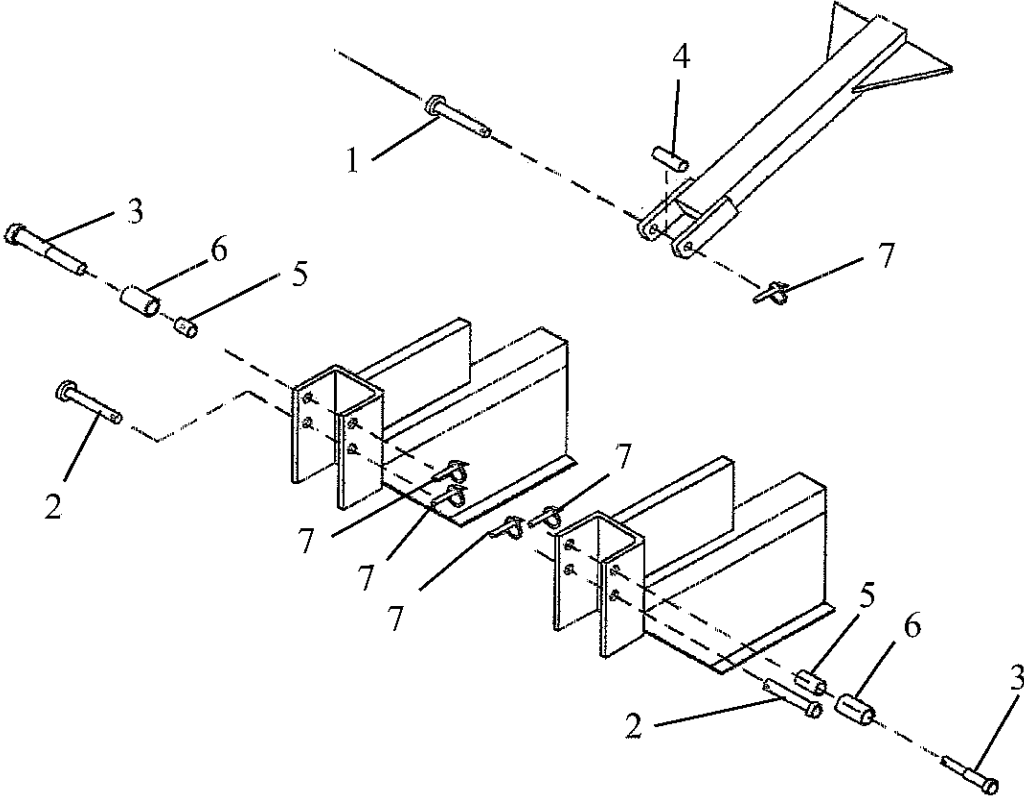

ITEM	PART NO.	QTY.	DESCRIPTION
1	00784030	1	UPPER 3PT HITCH PIN
2	00784031	2	LOWER CAT III HITCH PIN
3	00784032	2	LOWER CAT II HITCH PIN
4	00784033	1	BUSHING, UPPER HITCH PIN
5	00784034	2	BUSHING, LOWER INNER HITCH PIN
6	00784035	2	BUSHING, LOWER OUTER HITCH PIN
7	0838404	5	KLICK PIN 7/16 X 2

HITCH - CAT. II QUICK HITCH ASY - (OPTIONAL)

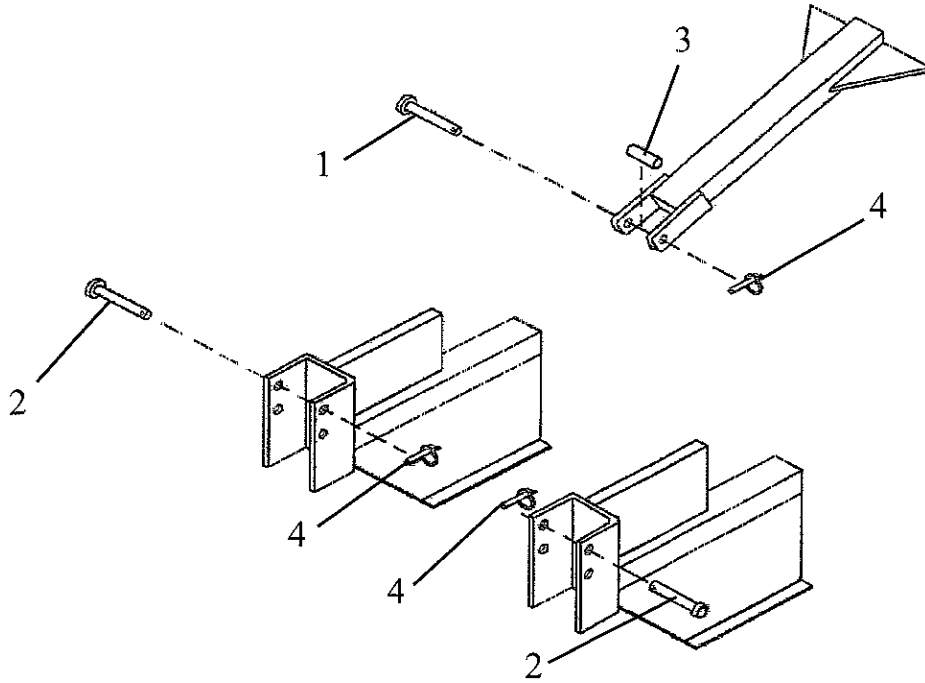

ITEM	PART NO.	QTY.	DESCRIPTION
1	00784030	1	UPPER 3PT HITCH PIN
2	00784031	2	LOWER CAT III HITCH PIN
3	00784033	1	BUSHING, UPPER HITCH PIN
4	0838404	3	KLICK PIN 7/16 X 2

HITCH - CAT. II & III QUICK HITCH ASY - (OPTIONAL)

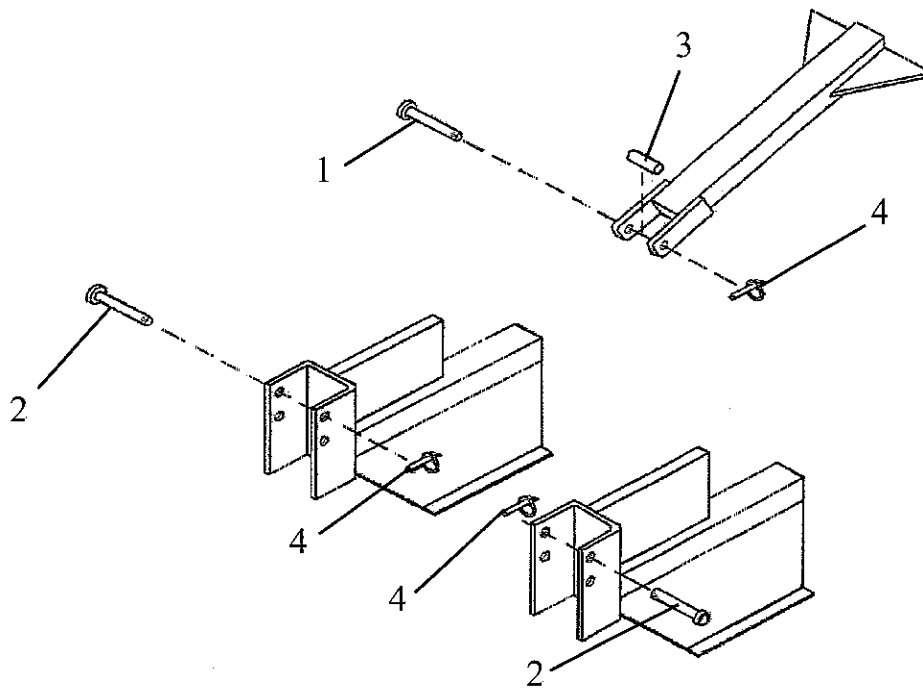

ITEM	PART NO.	QTY.	DESCRIPTION
1	00784030	1	UPPER 3PT HITCH PIN
2	00784031	2	LOWER CAT III HITCH PIN
3	00784033	1	BUSHING, UPPER HITCH PIN
4	0838404	3	KLICK PIN 7/16 X 2

HITCH - CAT. II & III W/O QUICK HITCH ASY - (STANDARD)

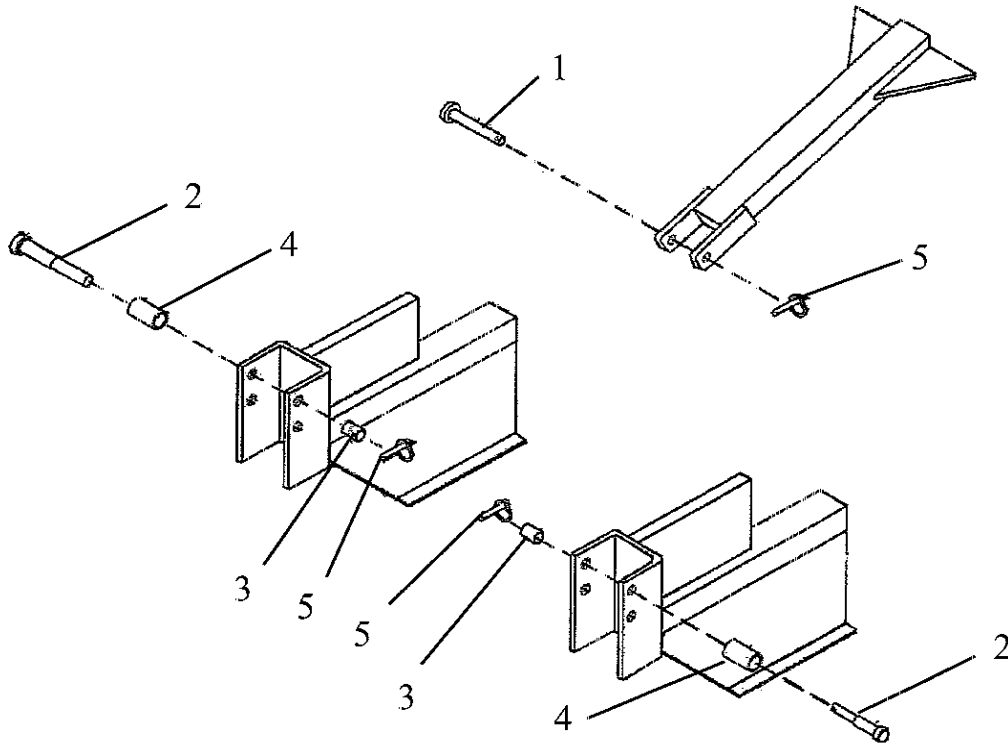

ITEM	PART NO.	QTY.	DESCRIPTION
1	00784030	1	UPPER 3PT HITCH PIN
2	00784032	2	LOWER CAT II HITCH PIN
3	00784034	2	BUSHING, LOWER INNER HITCH PIN
4	00784035	2	BUSHING, LOWER OUTER HITCH PIN
5	0838404	3	KLICK PIN 7/16 X 2

HITCH - CAT. III W/O QUICK HITCH ASY - (STANDARD)

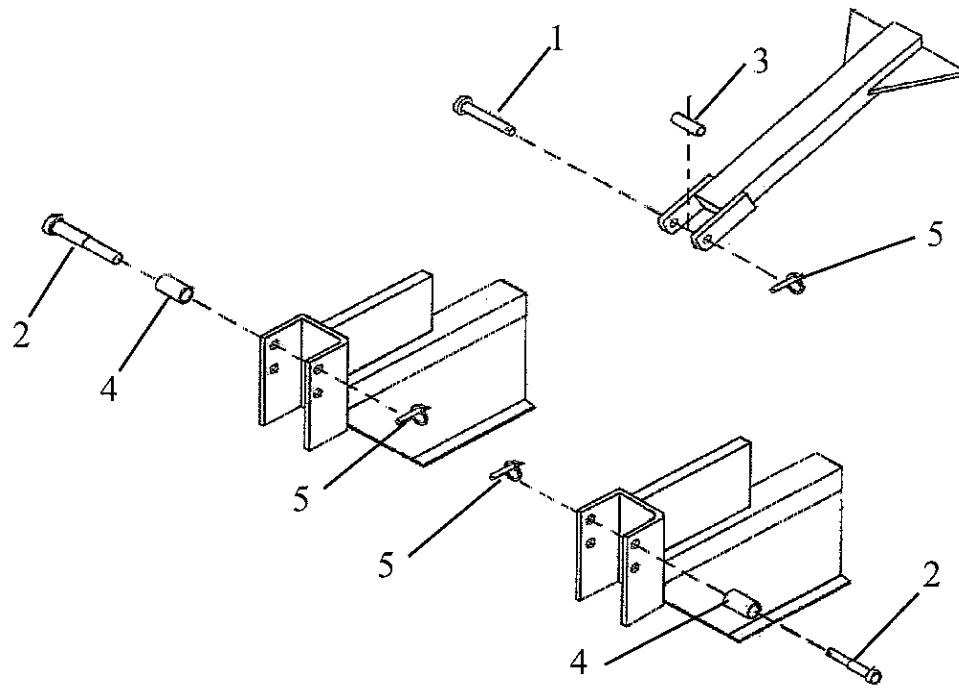

ITEM	PART NO.	QTY.	DESCRIPTION
1	00784030	1	UPPER 3PT HITCH PIN
2	00784031	2	CAT III HITCH PIN
3	00784033	1	BUSHING, UPPER HITCH PIN
4	00784035	2	BUSHING, LOWER OUTER HITCH PIN
5	0838404	3	KLICK PIN 7/16 X 2

SPOUT ASY - (OPTIONAL)

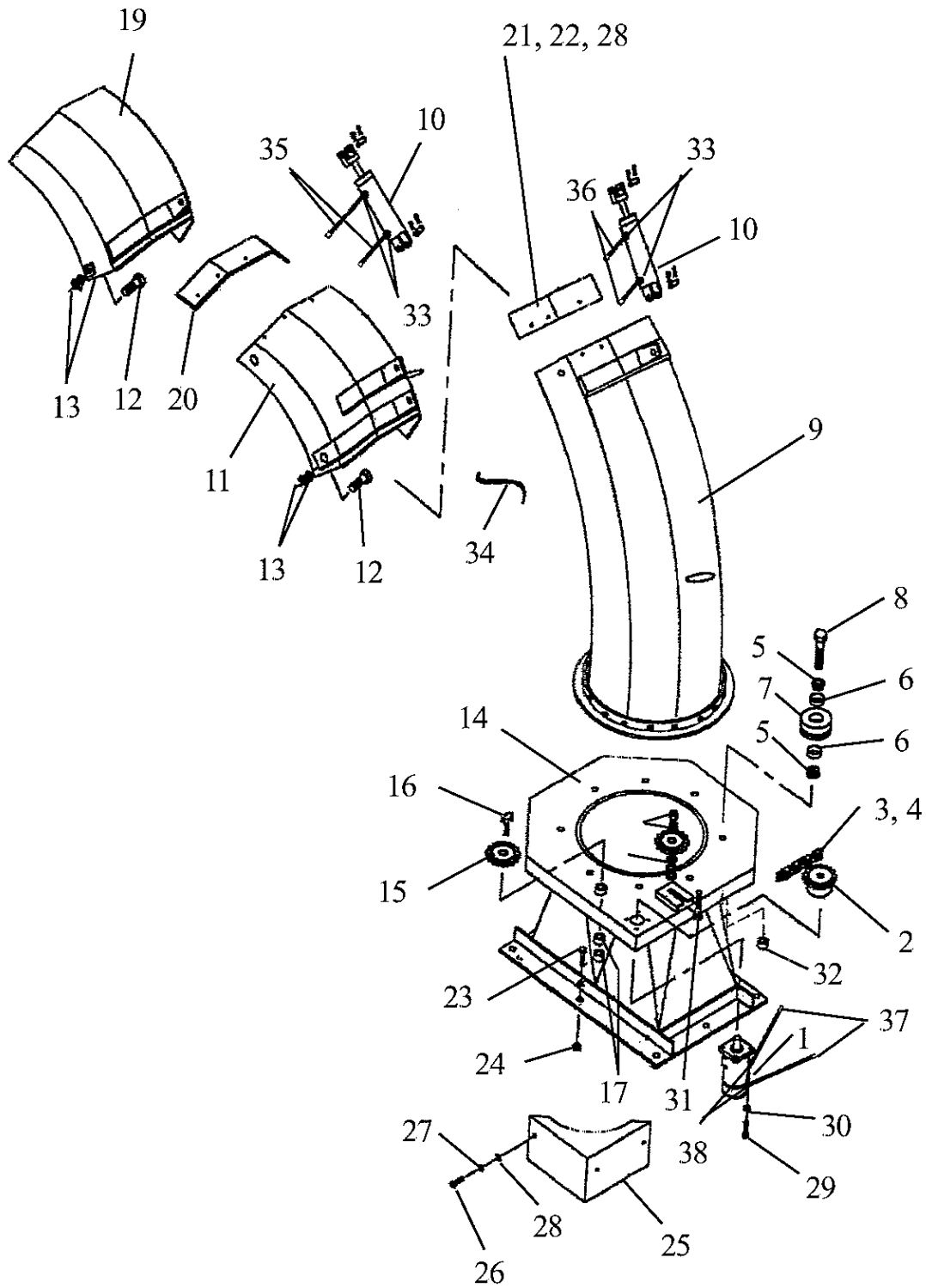

SPOUT ASY - (OPTIONAL)

ITEM	PART NO.	QTY.	DESCRIPTION
1	00783779	1	HYD MOTOR, 4 -BOLT MOUNT
2	00784098	1	HUB & SPROCKET
3	00783735	1	CHAIN, ROLLER 2060 X 60
4	00783736	1	CONNECTOR LINK, 2060
5	00783589	16	BEARING CONE
6	6W604	16	BEARING CUP
7	00783155	8	HOLD DOWN
8	317010H5C	8	HEX CAP 3/4-10 X 3 1/2 GR.5
9	00784091	1	SPOUT, PRIMARY
10	00783837	2	CYLINDER , HYDRUALIC 2X6
11	00784092	1	SECONDARY SPOUT
12	31795H5C	4	HEXB 1 NC X 2 -1/2 PL5
13	23511000	8	NUT JAM HEX 1 NC PL
14	00784094	1	SPOUT BASE
15	00783716	2	IDLER SPROCKET-15 TOOTH
16	316013H5C	1	HEX CAP 5/8-11 X 3 1/2 GR.5
17	33007C	4	HEX NUT 5/8-11
18	00001400	4	FLATWASHER 5/8 PL
19	00784093	1	SPOUT CAP
20	00784099	2	FLASHING, SPOUT RUBBER
21	31064H5C	14	FLAT SCKHD CPSC 1/4-20 X 3/4 PL5
22	33111C	14	HEX JAM NUT 1/4-20
23	02845500	8	HEXB 5/8 NC 2 PL5
24	00695100	8	NUT, TOPLOCK 5/8 NC PLB
25	00784095	1	SHIELD, MOTOR
26	10058000	3	HHCS 1/4 NC 1 PL5
27	00017000	3	LOCKWASHER 1/4 PL
28	00024100	17	FLATWASHER STD 1/4 PL
29	00011400	4	HHCS 3/8 NC 1 PL5
30	03101646	4	LOCKWASHER, 3/8
31	00783290	1	LOCK BOLT
32	00000200	8	NUT 3/4 NC
33	63149100	4	ADAPTER, HYD, ELBOW 6MB-6MJ 90 DG
34	0138629	2	TY RAP, 13 LONG
35	00784100	2	HYDRUALIC HOSE, 1/4 X145
36	00784101	2	HYDRUALIC HOSE, 1/4 X136
37	00784102	2	HYDRUALIC HOSE, 3/8 X35
38	11103	2	STREET ELBOW 1/2 X 90 DG
39	2727100	6	MALE HYD. TIP, 1/2 NPTF (NOT SHOWN)

Alamo Industrial

LIMITED WARRANTY

1. LIMITED WARRANTIES

- 1.01. Servis-Rhino warrants for one year from the purchase date to the original non-commercial, governmental, or municipal purchaser ("Purchaser") and warrants for six months to the original commercial or industrial purchaser ("Purchaser") that the goods purchased are free from defects in material or workmanship.
- 1.02. Manufacturer will replace for the Purchaser any part or parts found, upon examination at one of its factories, to be defective under normal use and service due to defects in material or workmanship.
- 1.03. This limited warranty does not apply to any part of the goods which has been subjected to improper or abnormal use, negligence, alteration, modification, or accident, damaged due to lack of maintenance or use of wrong fuel, oil, or lubricants, or which has served its normal life. This limited warranty does not apply to any part of any internal combustion engine, or expendable items such as blades, shields, guards, or pneumatic tires except as specifically found in your Operator's Manual.
- 1.04. Except as provided herein, no employee, agent, Dealer, or other person is authorized to give any warranties of any nature on behalf of Manufacturer.

2. REMEDIES AND PROCEDURES.

- 2.01. This limited warranty is not effective unless the Purchaser returns the Registration and Warranty Form to Manufacturer within 30 days of purchase.
- 2.02. Purchaser claims must be made in writing to the Authorized Dealer ("Dealer") from whom Purchaser purchased the goods or an approved Authorized Dealer ("Dealer") within 30 days after Purchaser learns of the facts on which the claim is based.
- 2.03. Purchaser is responsible for returning the goods in question to the Dealer.
- 2.04. If after examining the goods and/or parts in question, Manufacturer finds them to be defective under normal use and service due to defects in material or workmanship, Manufacturer will:
 - (a) Repair or replace the defective goods or part(s) or
 - (b) Reimburse Purchaser for the cost of the part(s) and reasonable labor charges (as determined by Manufacturer) if Purchaser paid for the repair and/or replacement prior to the final determination of applicability of the warranty by Manufacturer.The choice of remedy shall belong to Manufacturer.
- 2.05. Purchaser is responsible for any labor charges exceeding a reasonable amount as determined by Manufacturer and for returning the goods to the Dealer, whether or not the claim is approved. Purchaser is responsible for the transportation cost for the goods or part(s) from the Dealer to the designated factory.

3. LIMITATION OF LIABILITY.

- 3.01. MANUFACTURER DISCLAIMS ANY EXPRESS (EXCEPT AS SET FORTH HEREIN) AND IMPLIED WARRANTIES WITH RESPECT TO THE GOODS INCLUDING, BUT NOT LIMITED TO, MERCHANTABILITY AND FITNESS FOR A PARTICULAR PURPOSE.
- 3.02. MANUFACTURER MAKES NO WARRANTY AS TO THE DESIGN, CAPABILITY, CAPACITY, OR SUITABILITY FOR USE OF THE GOODS.
- 3.03. EXCEPT AS PROVIDED HEREIN, MANUFACTURER SHALL HAVE NO LIABILITY OR RESPONSIBILITY TO PURCHASER OR ANY OTHER PERSON OR ENTITY WITH RESPECT TO ANY LIABILITY, LOSS, OR DAMAGE CAUSED OR ALLEGED TO BE CAUSED DIRECTLY OR INDIRECTLY BY THE GOODS INCLUDING, BUT NOT LIMITED TO, ANY INDIRECT, SPECIAL, CONSEQUENTIAL, OR INCIDENTAL DAMAGES RESULTING FROM THE USE OR OPERATION OF THE GOODS OR ANY BREACH OF THIS WARRANTY. NOTWITHSTANDING THE ABOVE LIMITATIONS AND WARRANTIES, MANUFACTURER'S LIABILITY HEREUNDER FOR DAMAGES INCURRED BY PURCHASER OR OTHERS SHALL NOT EXCEED THE PRICE OF THE GOODS.
- 3.04. NO ACTION ARISING OUT OF ANY CLAIMED BREACH OF THIS WARRANTY OR TRANSACTIONS UNDER THIS WARRANTY MAY BE BROUGHT MORE THAN TWO (2) YEARS AFTER THE CAUSE OF ACTION HAS OCCURRED.

4. MISCELLANEOUS.

- 4.01. Proper Venue for any lawsuits arising from or related to this limited warranty shall be only in Guadalupe County, Texas.
- 4.02. Manufacturer may waive compliance with any of the terms of this limited warranty, but no waiver of any terms shall be deemed to be a waiver of any other term.
- 4.03. If any provision of this limited warranty shall violate any applicable law and is held to be unenforceable, then the invalidity of such provision shall not invalidate any other provisions herein.
- 4.04. Applicable law may provide rights and benefits to purchaser in addition to those provided herein.

KEEP FOR YOUR RECORDS

ATTENTION: Purchaser should fill in the blanks below for his reference when buying repair parts and/or for proper machine identification when applying for warranty.

Servis-Rhino Implement Model _____ Serial Number _____

Date Purchased _____ Dealer _____

ATTENTION:
READ YOUR OPERATOR'S MANUAL





TO THE OWNER/OPERATOR/DEALER

To keep your implement running efficiently and safely, read your manual thoroughly and follow these directions and the Safety Messages in this Manual. The Table of Contents clearly identifies each section where you can easily find the information you need.

The OCCUPATIONAL SAFETY AND HEALTH ACT (1928.51 Subpart C) makes these minimum safety requirements of tractor operators:

REQUIRED OF THE OWNER:

1. Provide a Roll-Over-Protective Structure that meets the requirements of this Standard; and
2. Provide Seatbelts that meet the requirements of this paragraph of this Standard and SAE J4C; and
3. Ensure that each employee uses such Seatbelt while the tractor is moving; and
4. Ensure that each employee tightens the Seatbelt sufficiently to confine the employee to the protected area provided by the ROPS.

REQUIRED OF THE OPERATOR

1. Securely fasten seatbelt if the tractor has a ROPS.
2. Where possible, avoid operating the tractor near ditches, embankments, and holes.
3. Reduce speed when turning, crossing slopes, and on rough, slick, or muddy surfaces.
4. Stay off slopes too steep for safe operation.
5. Watch where you are going - especially at row ends, on roads, and around trees.
6. Do not permit others to ride.
7. Operate the tractor smoothly - no jerky turns, starts, or stops.
8. Hitch only to the drawbar and hitch points recommended by the tractor manufacturer.
9. When the tractor is stopped, set brakes securely and use park lock, if available.



Keep children away from danger all day, every day...



Equip tractors with rollover protection (ROPS) and keep all machinery guards in place...



Please work, drive, play and live each day with care and concern for your safety and that of your family and fellow citizens.



G/W Snow Blower - 8600AR - (08-05)

© 2005 Alamo Industrial