



AT 60/74

THREE-POINT MOUNTED FLAIL MOWERS

Published 06 - 05

P/N 00761305P

PART'S MANUAL

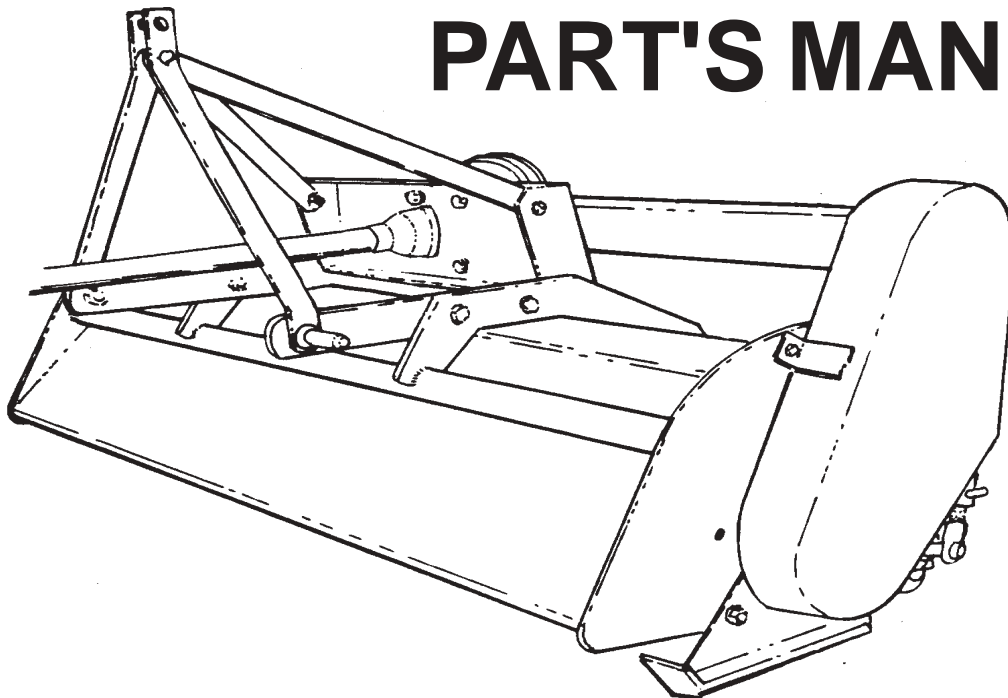

ATENCIÓN!

LEA EL INSTRUCTIVO

Si No Lee Ingles, Pida Ayuda a Alguien
Que Si Lo Lea Para Que le Traduzca las
Medidas de Seguridad.



An Operator's Manual was shipped with the equipment in the Manual Canister. This Operator's Manual is an integral part of the safe operation of this machine and must be maintained with the unit at all times. **READ, UNDERSTAND, and FOLLOW** the Safety and Operation Instructions contained in this manual before operating the equipment. If the Operator's Manual is not with the equipment, contact your dealer or Alamo Industrial (830-379-1480) to obtain a Free copy before operating the equipment.

ALAMO INDUSTRIAL

1502 E. Walnut
Seguin, Texas 78155
830-379-1480



TO THE OWNER/OPERATOR/DEALER

All implements with moving parts are potentially hazardous. There is no substitute for a cautious, safe-minded operator who recognizes the potential hazards and follows reasonable safety practices. The manufacturer has designed this implement to be used with all its safety equipment properly attached to minimize the chance of accidents.

BEFORE YOU START!! Read the safety messages on the implement and shown in your manual.
Observe the rules of safety and common sense!



DANGER

FAILING TO FOLLOW SAFETY MESSAGES AND OPERATING INSTRUCTIONS CAN CAUSE SERIOUS BODILY INJURY OR EVEN DEATH TO OPERATOR AND OTHERS IN THE AREA.

<p>1.</p>	<p>2. NO RIDERS, NO CHILDREN OPERATORS</p>	<p>3. USE SAFETY SHOES, HARD HAT, SAFETY GLASSES, SEAT BELTS, & ROPS</p>	<p>4. BLOCK UP SECURELY BEFORE WORKING UNDER.</p>
-----------	--	--	---

1. Study and understand Operator's Manuals, Safety Signs, and Instructional Decals for tractor & flail mower to prevent misuse, abuse, & accidents. Practice before operating mower in a confined area or near passersby.
 - Learn how to stop engine suddenly in an emergency. Be alert for passersby and especially children.
2. Allow no children on or near implement or tractor. Allow no riders on tractor or implement. Falling off can cause serious injury or death from being runover by tractor or mower or contact with Flail Mower Blades.
3. Operate only with tractor having Roll-Over Protective Structure (ROPS) and with seatbelt fastened securely and snugly to prevent injury and possible death from falling off or tractor overturn. Personal Protective Equipment such as Hard Hat, Safety Glasses, Safety Shoes, and Ear Plugs are recommended.
4. Block up or support raised machine and all lifted components securely before putting hands or feet under or working underneath any lifted component to prevent crushing injury or death from sudden dropping or inadvertent operation of controls. Make certain that area is clear before lowering or folding.
5. Before transporting, put Lift Lever in detent or full-lift position. Install Transport Safety Devices securely on folding implements. Slow down when turning and on hillsides.
 - Install **Restrictor in folding circuit to slow down lowering and unfolding if action is faster than is desirable.
6. Make certain that SMV sign, Warning Lights, and Reflectors are clearly visible. Follow local traffic codes.
7. Never operate with Flail Mower or Folding Section raised if passersby, bystanders or traffic are in the area to reduce possibility of injury or death from objects thrown by Blades under Shields or implement structure.
8. Before dismounting, secure flail mower in transport position or lower to ground.
 - Put tractor in park or set brake, disengage PTO, stop engine, remove key, and wait until noise of rotation has ceased to prevent entanglement in rotating parts which may cause injury or death.
 - Never mount or dismount a moving vehicle. Crushing from runover may cause injury or death.

<p>5. TRANSPORT SAFELY, LOCK UP.</p>	<p>6. USE SMV, LIGHTS, & REFLECTORS.</p>	<p>7. DO NOT OPERATE WITH MOWER OR WING RAISED.</p>	<p>8. DO NOT MOUNT OR DISMOUNT WHILE MOVING.</p>
--------------------------------------	--	---	--

Read and understand the complete Warranty Statement found in this Manual. Fill out the Warranty Registration Form in full and return it within 30 Days. Make certain the Serial Number of the Machine is recorded on the Warranty Card and on the Warranty Form that you retain. The use of "will-fit" parts will void your warranty and can cause catastrophic failure with possible injury or death.

WARRANTY INFORMATION

002369

PARTS SECTION

PARTS ORDERING GUIDE

The following instructions are offered to help eliminate needless delay and error in processing purchase orders for the equipment in this section.

1. The Parts Section is prepared in logical sequence and grouping of parts that belong to the basic machine featured in this manual. Part Numbers and Descriptions are given to help locate the parts and quantities required.
2. The Purchase Order must include the name and address of the person or organization ordering the parts, who should be charged, and if possible, the serial number of the machine for which the parts are ordered.
3. The Purchase Order must clearly list the quantity of each part, the complete and correct part number (be sure to include all periods), and the basic name of the part.
4. The Manufacturer reserves the right to substitute parts where applicable.
5. Some parts are unlisted items which are special production items not normally stocked and are subject to special handling. Request a quotation for such parts before sending a Purchase Order.
6. The Manufacturer reserves the right to change prices without prior notice.

NOTE: Please refer to The Safety Section in the front of this Manual for the proper Part Number when ordering Replacement Safety Decals.



For maximum safety and to guarantee optimum product reliability, always use genuine Servis-Rhino Parts. The use of inferior replacement parts may cause premature or catastrophic failure which could result in serious injury or death. Direct any questions regarding parts to:

**//////ALAMO
INDUSTRIAL™**

ALAMO INDUSTRIAL

1502 E. Walnut
Seguin, Texas 78155
830-379-1480



PART NAME INDEX

CASTER WHEEL PACKAGE	18
DRIVE SHAFT ASSEMBLY (P/N 001867).....	6
DRIVE SHAFT ASSEMBLY (P/N 00775472).....	19
DRIVE SHAFT ASSEMBLY (PN 001862).....	8
GENERAL ASY.....	7
PULLEY ASSEMBLY	11
REVERSE GEARBOX ASSEMBLY (P/N 702673)	10
ROLLER AND CUTTERSHAFT ASSEMBLY	13
SAFETY	4
SHIELDS, SKID SHOES & RUBBER FLAPS	15
60" A-FRAME ASSEMBLY	5
74" OFFSET A-FRAME ASSEMBLY.....	17

SAFETY

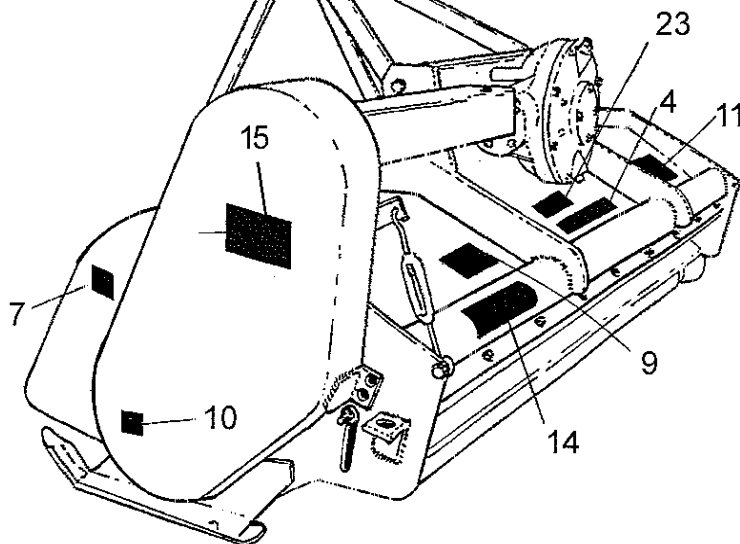
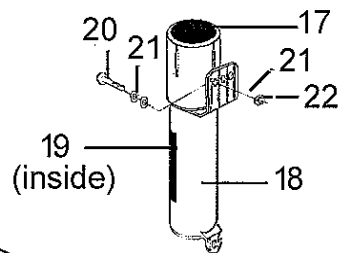
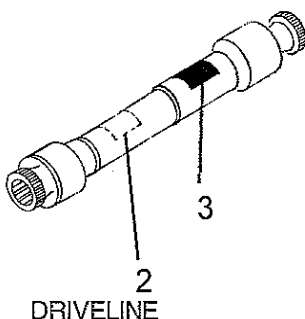
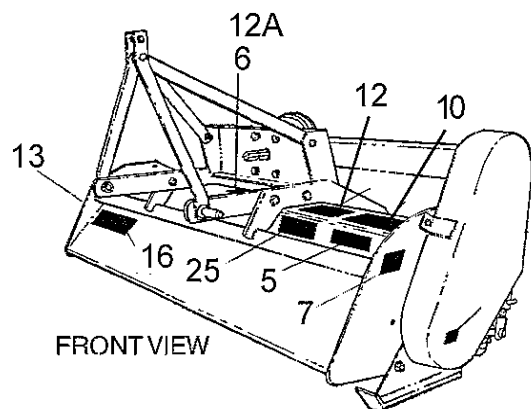

ITEM	PART NO.	QTY	LEVEL	DESCRIPTION
1	002369	1	DANGER	MULTI - HAZARD
2	00756004	1	DANGER	D/L SHIELD MISSING
3	00756005	1	DANGER	ROTATING DRIVELINE
4	00725739	1	WARNING	USE/REPAIR SHIELDS & GUARDS
5	02967668	1	DANGER	CUTTING BLADES / THROWN OBJECTS
6	00756494	1	DANGER	D/L MULTI HAZ
7	00758194	1	WARNING	PINCH POINT (V-BELT / PULLEY)
8	03200347	1	REFLCTR	SMV REFLECTOR
9	000108	1	Instruc	FLAIL OPERATION
10	000678	2	Instruc	GREASE FITTING INSIDE
11	001830	1	Instruc	LUBRICATION CHART
12	02925100	1	Instruc	GENUINE PARTS, FLAIL
12A	00773723	1	PELIGRO!	ROTATING DRIVELINE TRANSLATION
13	001650	1	Logo	ALAMO BY MOTT
14	001651	1	Logo	ALAMO
15	02960766	1	Logo	ALAMO
16	NFS	1	Ser Pit	SERIAL PLATE
17	00776481	1	Instruc	OPERATOR'S MANUAL INSIDE (DECAL)
18	00776031	1	-----	CANISTER, OPERATOR'S MANUAL
19	00761305C	1	-----	OPERATOR'S MANUAL
20	10058000	3	-----	BOLT
21	00024100	6	-----	FLATWASHER
22	02959924	3	-----	LOCKNUT
23	00725746	1	PELIGRO!	SPANISH TRANSLATION

60" A-FRAME ASSEMBLY

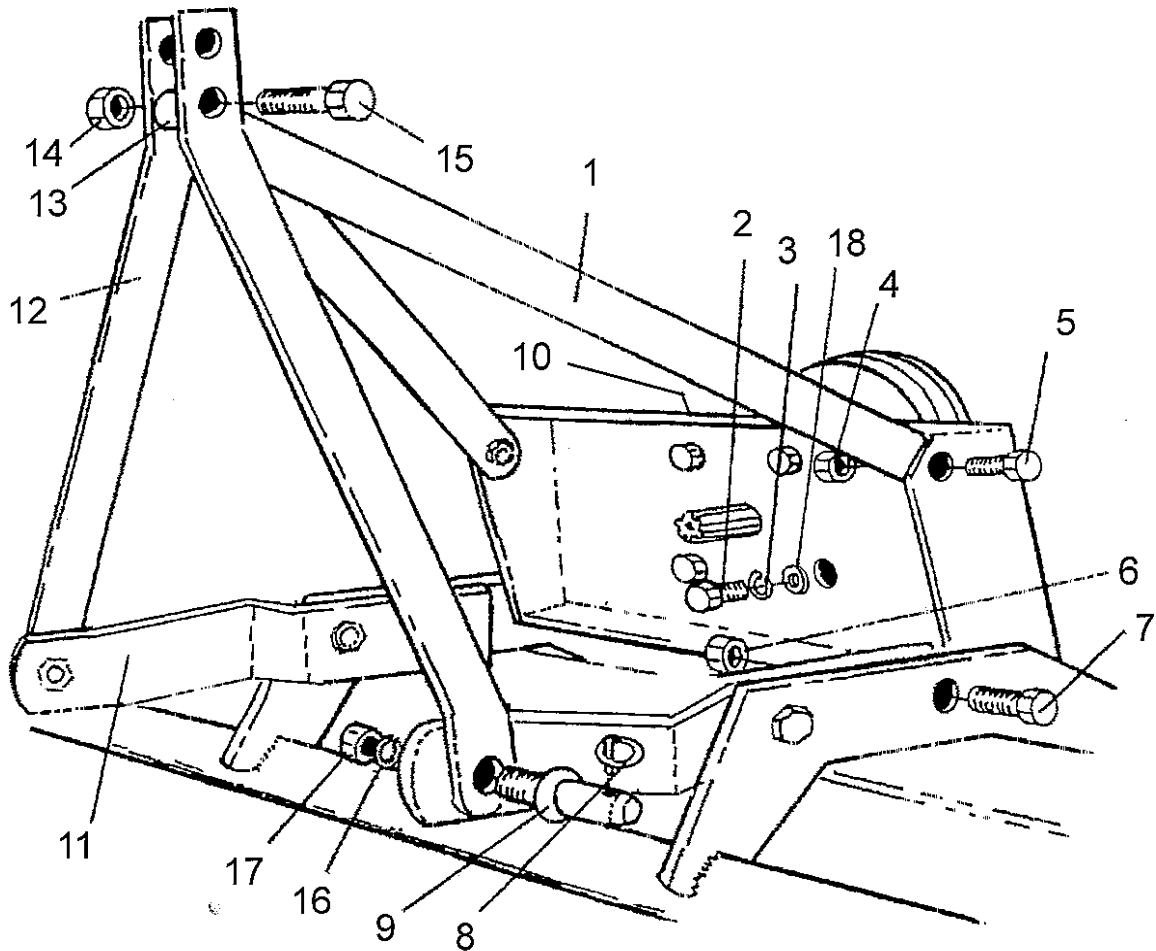

ITEM	PART NO.	QTY.	DESCRIPTION
1	102802	2	UPPER STRUT
2	02675800	4	BOLT
3	00010300	4	LOCKWASHER
4	00001800	2	LOCKNUT
5	02030700	2	BOLT
6	00695100	4	LOCKNUT
7	02045000	4	BOLT
8	2196	2	LYNCH PIN
9	00603500	2	CATEGORY I HITCH PIN WITH NUT AND LOCKWASHER
10	000552	6	SHIM (AS NEEDED) - SEE ASSEMBLY 3-4
11	106623	2	HITCH ARM
12	100022	2	FRONT STRUT
13	102803	1	STRUT SPACER
14	00001800	1	LOCKNUT
15	00999418	1	BOLT
16	00012200	2	LOCKWASHER
17	00603600	2	NUT
18	00001400	4	FLATWASHER

DRIVE SHAFT ASSEMBLY (P/N 001867)

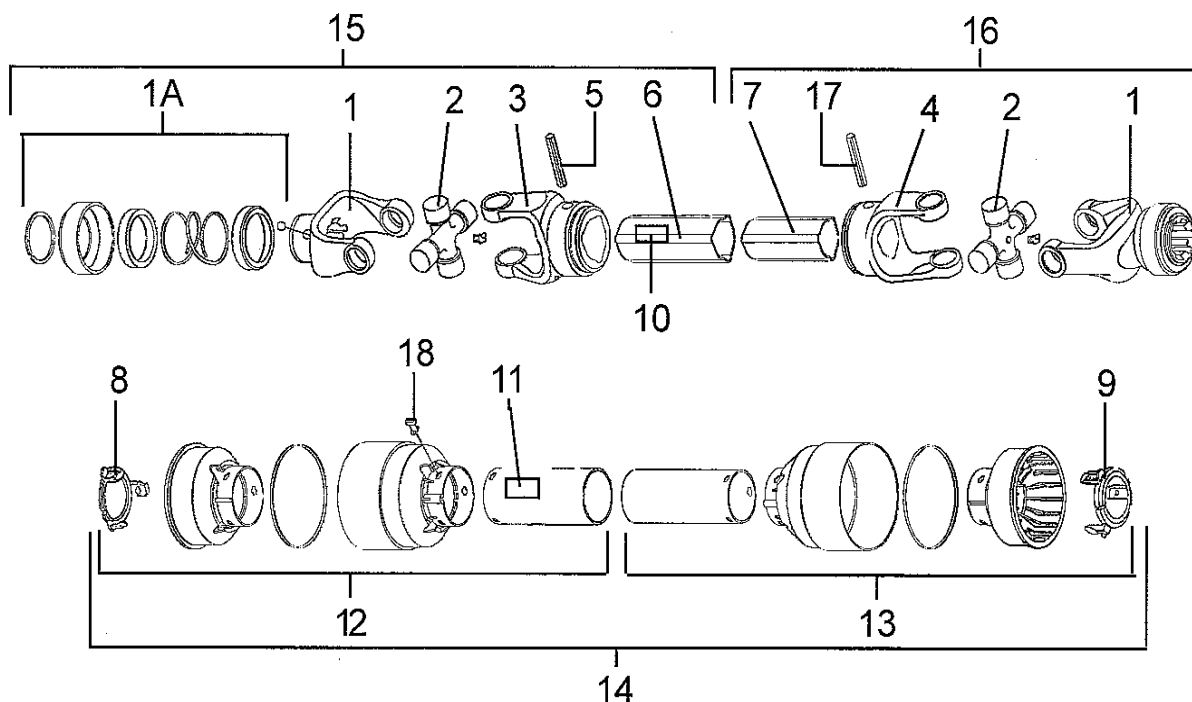

ITEM	PART NO.	QTY.	DESCRIPTION
	001867		DRIVE SHAFT ASY.
1	00764500	2	YOKE, W/ SLIDE COLLAR
1A	00757144	1	SLIDE COLLAR REPAIR KIT (ONLY)
2	00756231	2	CROSS & BEARING KIT
3	00759168	1	YOKE, OUTER TUBE
4	00759164	1	YOKE, INNER TUBE
5	00759169	1	ROLL PIN, OUTER TUBE
6	00759519	1	OUTER TUBE
7	00759518	1	INNER TUBE
8	00764506	1	INNER, COLLAR RETAINER
9	00764507	1	OUTER, COLLAR RETAINER
10	00756004	1	DECAL - SHIELD MISSING
11	00756005	1	DECAL - ROTATING DRIVELINE
12	00759528A	1	SHIELD ASY, OUTER HALF
13	00759529A	1	SHIELD ASY, INNER HALF
14	00759530A	1	SHIELD ASY. (COMPLETE)
15	00759523	1	OUTER SHAFT ASY. W/ SHIELD
16	00759522	1	INNER SHAFT ASY, W/ SHIELD
17	00759165	1	ROLL PIN, INNER TUBE
18	00754330	6	NYLON BOLT

GENERAL ASY

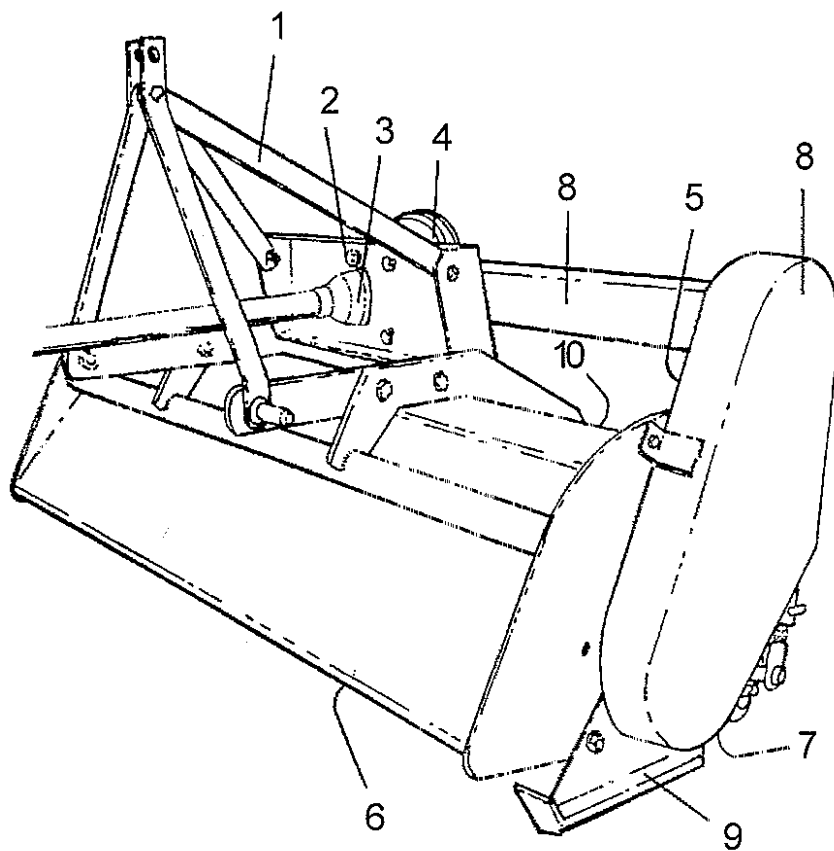

ITEM	PAGE NO.	DESCRIPTION
1	6-5	60" A-FRAME ASSEMBLY
2	6-8	GEAR BOX MOUNT
3	6-6	DRIVE SHAFT ASSEMBLY
4	6-8	GEAR BOX ASSEMBLY
5	6-10	PULLEY ASSEMBLY
6	6-12	CUTTERSHAFT ASSEMBLY
7	6-12	ROLLER ASSEMBLY
8	6-14	SHIELDS
9	6-14	SKID SHOES
10	6-14	RUBBER SKIRTS
*	6-16	74" OFFSET A-FRAME ASSEMBLY
*	6-17	TAILWHEEL ASSEMBLY

DRIVE SHAFT ASSEMBLY (PN 001862)

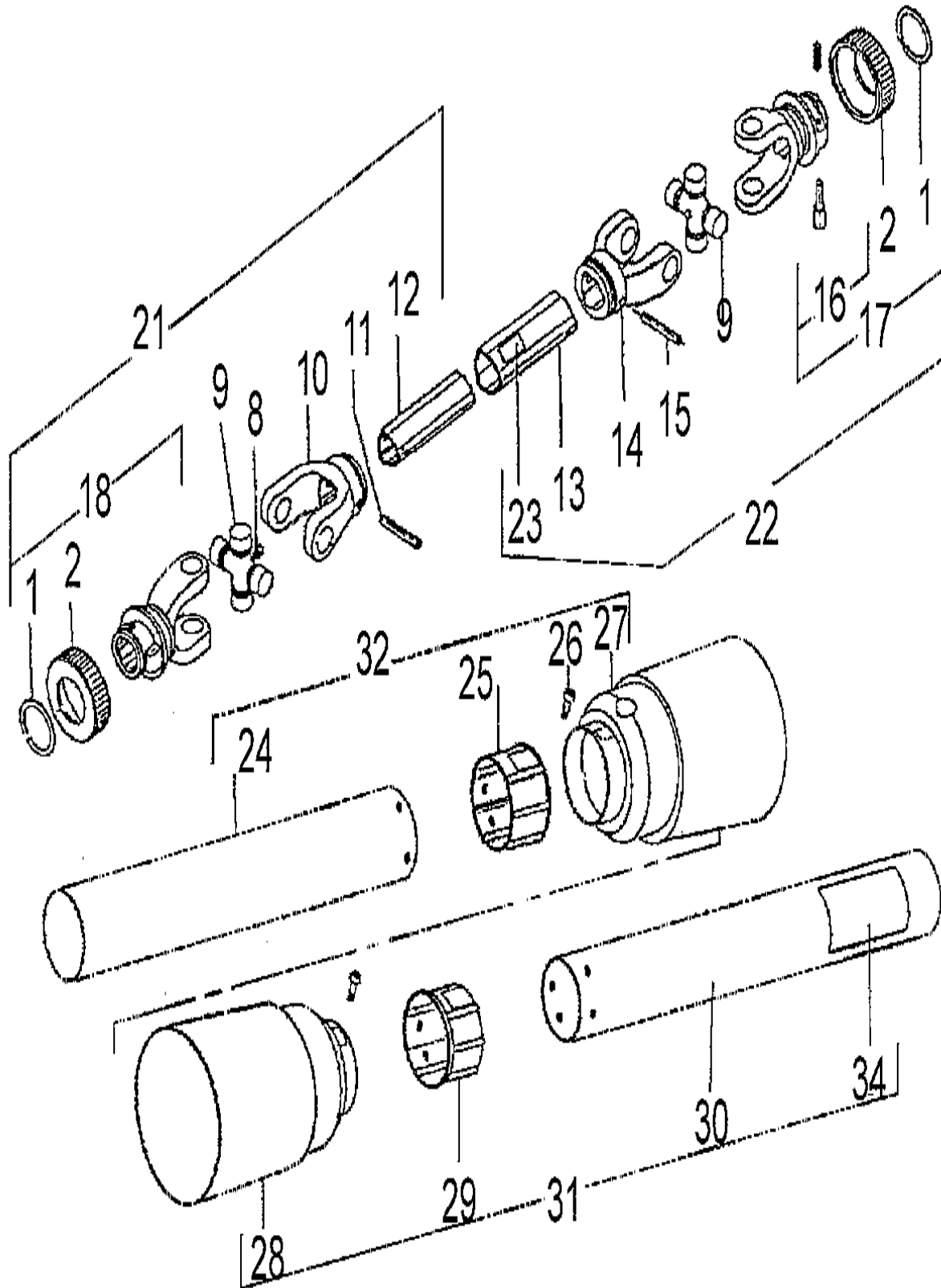

DRIVE SHAFT ASSEMBLY (PN 001862)

ITEM	PART NO.	QTY.	DESCRIPTION
	001862	---	DRIVE SHAFT ASY.
1	00759515	1	CIRCLIP
2	00759516	1	COLLAR LOCK
8	00759517	2	GREASE FITTING
9	00759163	2	CROSS & BEARING KIT
10	00759164	1	INNER YOKE
11	00759165	1	ROLL PIN
12	00759518	1	INNER TUBE
13	00759519	1	OUTER TUBE
14	00759168	1	OUTER YOKE
15	00759169	1	ROLL PIN
16	00754474	1	PUSH PIN SET
17	00759171	1	COLLAR KIT
18	00759170	1	OUTER YOKE, W/ QUICK RELEASE
19	00759520	1	INSIDE U-JOINT
20	00759521	1	OUTSIDE U-JOINT
21	00759522	1	INNER SHAFT W/ PROTECTOR
22	00759523	1	OUTER SHAFT W/ PROTECTOR
23	00756004	1	DRIVELINE WARNING LABEL
24	00759524	1	INNER TUBE
25	00759174	1	INNER TUBE BEARING
26	00759175	2	SCREW
27	00759526	1	STANDARD CONE
28	00759526	1	STANDARD CONE
29	00759527	1	OUTER TUBE BEARING
30	00759525	1	OUTER TUBE
31	00759528	1	FEMALE SHIELD HALF
32	00759529	1	MALE SHIELD HALF
33	00759530	1	COMPLETE SHIELD
34	00756005	1	DRIVELINE SHIELD WARNING LABEL

REVERSE GEARBOX ASSEMBLY (P/N 702673)

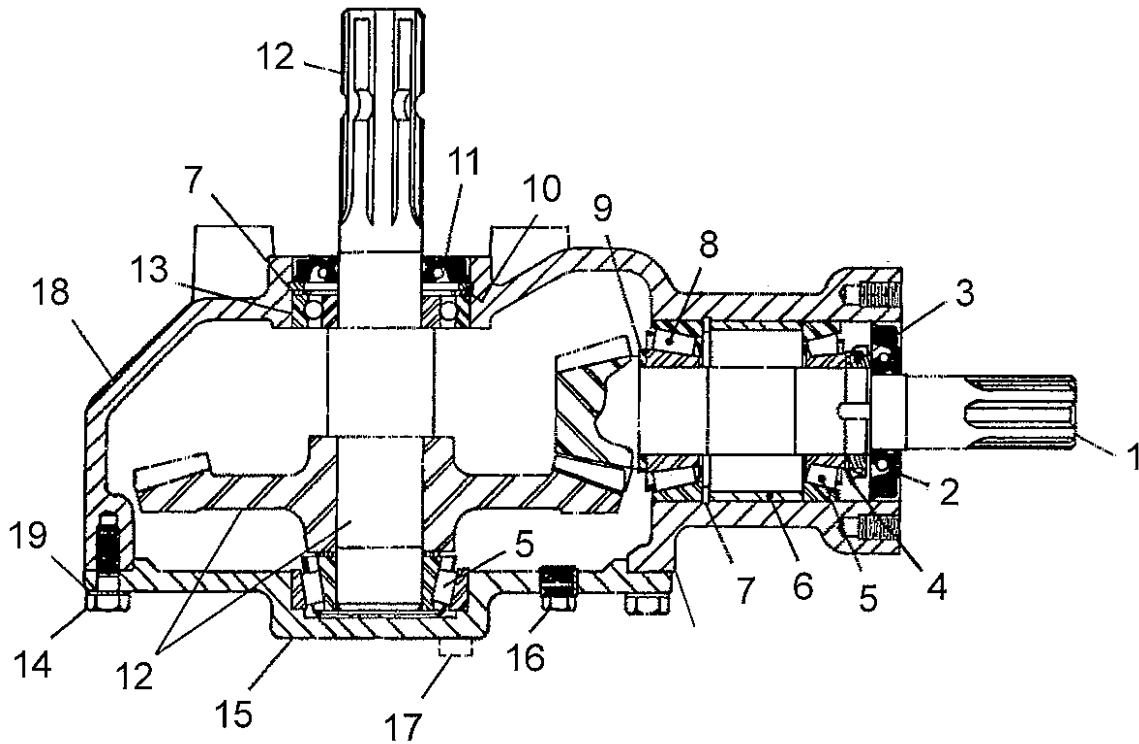

ITEM	PART NO.	QTY.	DESCRIPTION
	702673	---	GEARBOX ASY, (OILED & TESTED)
1	001718	1	PINION
2	001719	1	SEAL
3	001717	1	NUT
4	001720	1	SPRING WASHER
5	00754757	2	ROLLER BEARING
6	001716	1	SPACER
7	00754752	2	INTERNAL CIRCLIP
8	001722	1	ROLLER BEARING
9	00753222	2	SHIM
10	00754761	1	SHIM
11	001724	1	SEAL
12	001725	1	SHAFT W/GEAR
13	00754459	1	BALL BEARING
14	001708	8	BOLT
15	001710	1	COVER
16	00755633	2	PLUG
17	000055	2	DRAIN PLUG

PULLEY ASSEMBLY

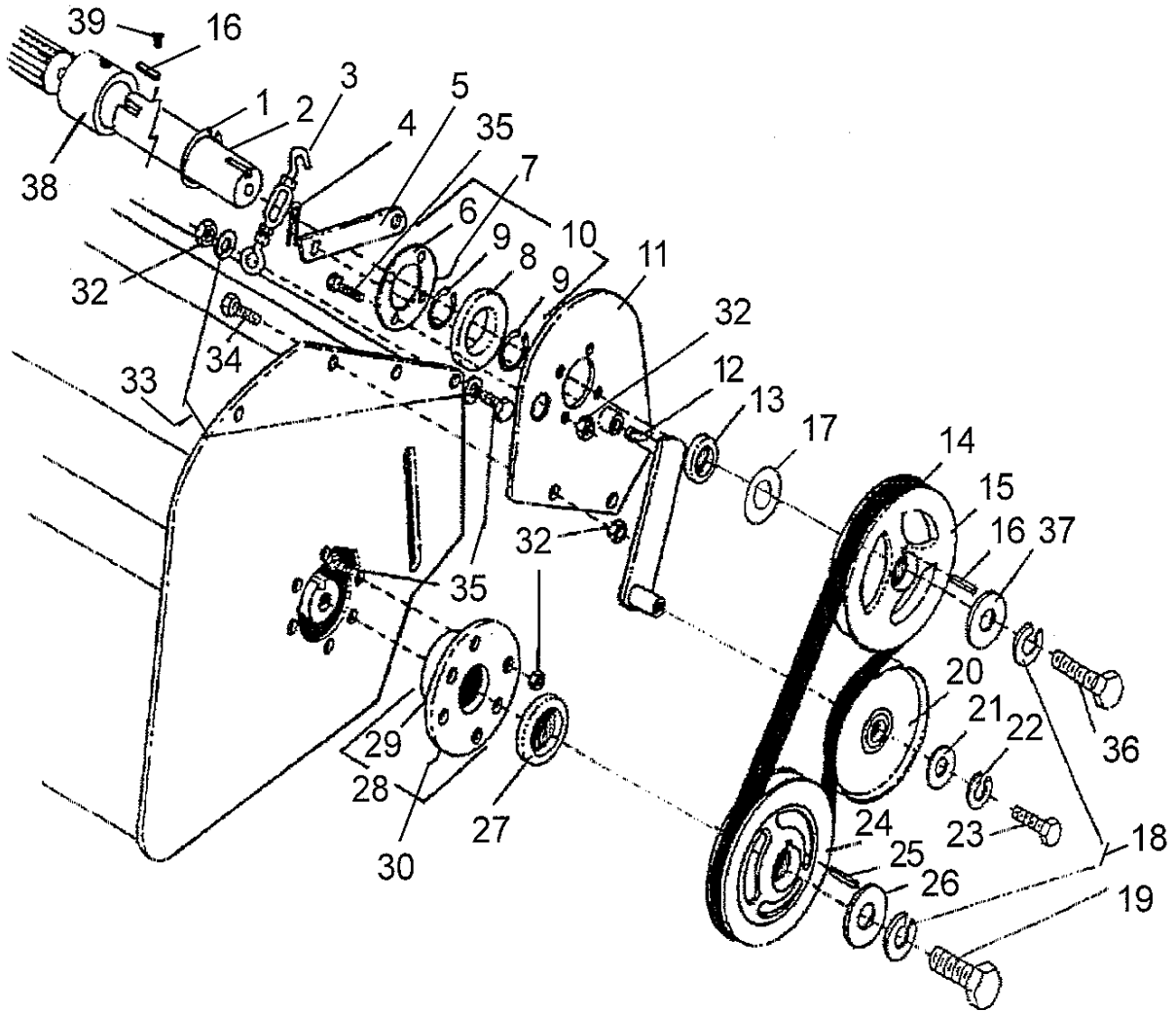

PULLEY ASSEMBLY

ITEM	QTY.	DESCRIPTION
1		00758900RETAINING RING
2		106641 AT 60, EXTENSION SHAFT
		107415 AT 74, EXTENSION SHAFT REVERSE ROTATION
		106640 AT 74, EXTENSION SHAFT FORWARD ROTATION
3		02961194TURNBUCKLE
4		00755153COTTER PIN
5		106786 SPRING ARM
6		700739 BEARING HOUSING
7		000053 GREASE FITTING
8		000398 BEARING
9		000402 RETAINING RING
10		700491 BEARING ASSEMBLY (ITEMS 6-9)
11		106630 BEARING SUPPORT
12		106789 IDLER ARM
13		106799 PULLEY SPACER
14		001585 V-BELT
15		102501 CUTTER SHAFT, DRIVE PULLEY
16		02669600SQUARE KEY
17		102651 SHIM
18		00019600LOCK WASHER
19		00607900BOLT
20		000547 IDLER PULLEY
21		00023500WASHER
22		00011700LOCK WASHER
23		00027100BOLT
24		106165 CUTTER SHAFT PULLEY
25		02959282SQUARE KEEPER KEY
26		103767 WASHER
27		15B2400 CUTTER SHAFT SPACER
28		703695 BEARING ASSEMBLY, DRIVE SIDE
29		002315 BEARING
30		00752176GREASE FITTING, W/ NIPPLE
32		00015800LOCKNUT
33		00011100WASHER
34		00011400BOLT
35		00753642BOLT
36		00748823BOLT
37		00002700WASHER
38		106970 SHAFT COUPLER
39		02957080SET SCREW

ROLLER AND CUTTERSHAFT ASSEMBLY

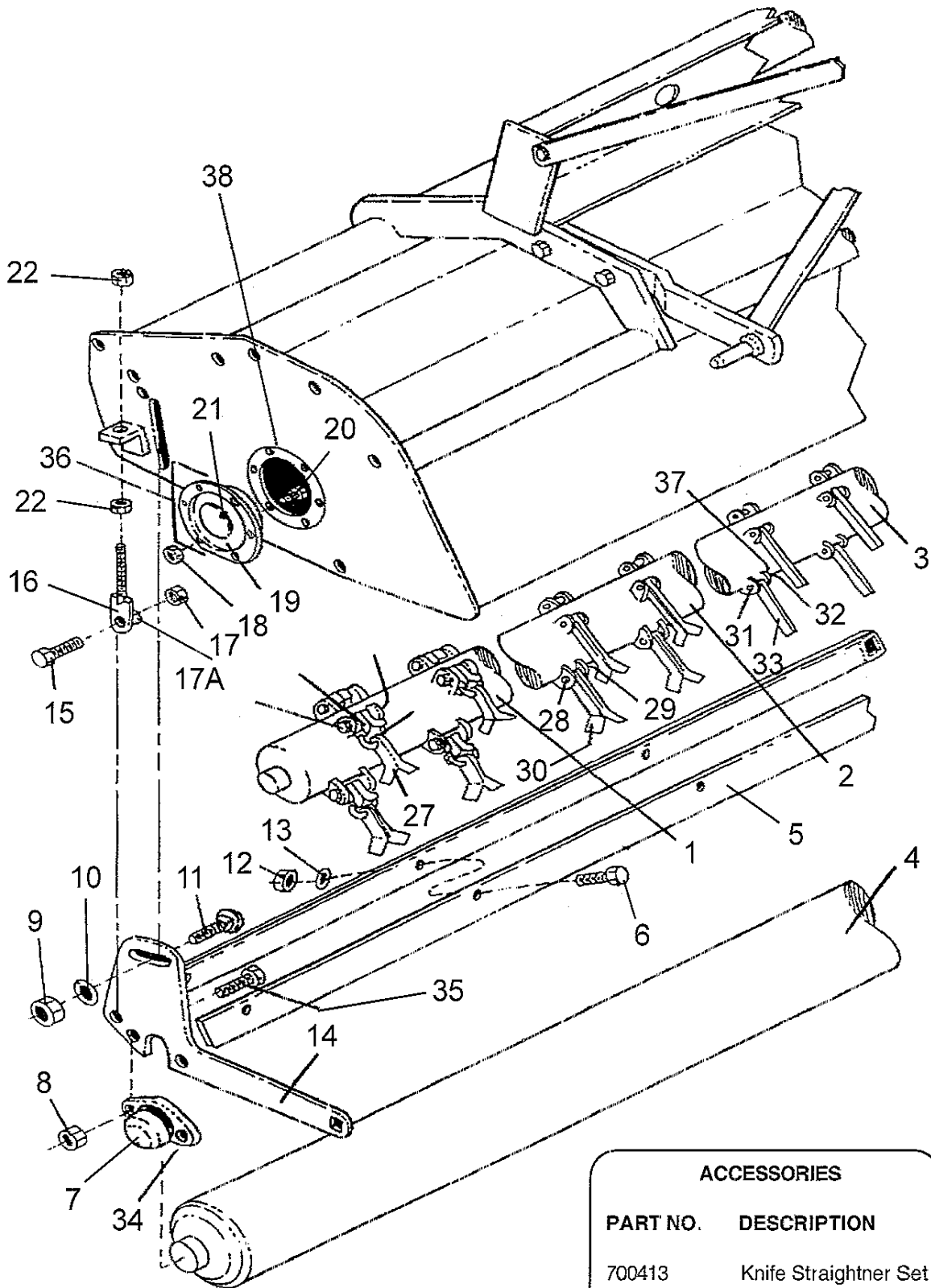

ACCESSORIES	
PART NO.	DESCRIPTION
700413	Knife Straightner Set
702321	Electric Knife Grinder

ROLLER AND CUTTERSHAFT ASSEMBLY

ITEM	PART NO.	QTY.	DESCRIPTION
1	106878	1	60" RING KNIFE CUTTERSHAFT WITH KNIVES
	703090	1	74" RING KNIFE CUTTERSHAFT WITH KNIVES
2	702616	1	60" FINE CUT CUTTERSHAFT WITH KNIVES
	702615	1	74" FINE CUT CUTTERSHAFT WITH KNIVES
3	106881	1	60" RENOVATING KNIFE CUTTERSHAFT WITH KNIVES
	703091	1	74" RENOVATING KNIFE CUTTERSHAFT WITH KNIVES
4	106652	1	60" ROLLER WELDMENT
	106651	1	74" ROLLER WELDMENT
5	106496	1	60" ROLLER SCRAPER
	106488	1	74" ROLLER SCRAPER
6	00013900	4	HEX BOLT (60" MOWER)
	00013900	5	HEX BOLT (74" MOWER)
7	001681	2	FLANGE BEARING
8	02957941	4	LOCKNUT
9	00001800	2	LOCKNUT
10	00002700	2	WASHER
11	02886900	2	BOLT
12	00015800	4	LOCKNUT (60" MOWER)
	00015800	5	LOCKNUT (74" MOWER)
13	00011100	4	WASHER (60" MOWER)
	00011100	5	WASHER (74" MOWER)
14	106498	1	60" ROLLER BRACKET WELDMENT
	106489	1	74" ROLLER BRACKET WELDMENT
15	02845500	2	BOLT
16	106800	2	ROLLER ADJUSTMENT ROD
17A	00010400	2	NUT
17	00695100	2	LOCKNUT
18	00015800	6	LOCKNUT
19	703694	1	BEARING WITH SETSCREW
20	00023100	6	BOLT
21	00752176	1	GREASE FITTING
22	00000200	4	NUT
23	000032	76(60")-92(74")	BOLT
24	105746	152(60")-184(74")	BRACKET CLIP
25	000210	76(60")-92(74")	NUT
26	101991	76(60")-92(74")	WASHER
27	101993	152(60")-184(74")	BRACKET KNIFE
28	101034	76(60")-92(74")	KNIFE PIN
29	000026	76(60")-92(74")	CUTTER PIN
30	102086	152(60")-184(74")	FINE CUT KNIFE
31	101034	76(60")-92(74")	KNIFE PIN
32	000026	76(60")-92(74")	CUTTER PIN
33	102087	76(60")-92(74")	RENOVATING KNIFE
34	106633	2	BEARING COVER
35	00022500	4	BOLT
36	703271	1	BEARING ASSEMBLY
37	000017	152(60")-184(74")	WASHER
38	002367	1	SPACER
	106060		60" CUTTERSHAFT (WITHOUT HARDWARE)
	701654		60" FINE CUT KNIFE SET
	702481		60" RING KNIFE SET
	700515		60" RENOVATING KNIFE SET
	700553		74" FINE CUT SET
	702482		74" RING KNIFE SET
	700516		74" RENOVATING KNIFE SET

SHIELDS, SKID SHOES & RUBBER FLAPS

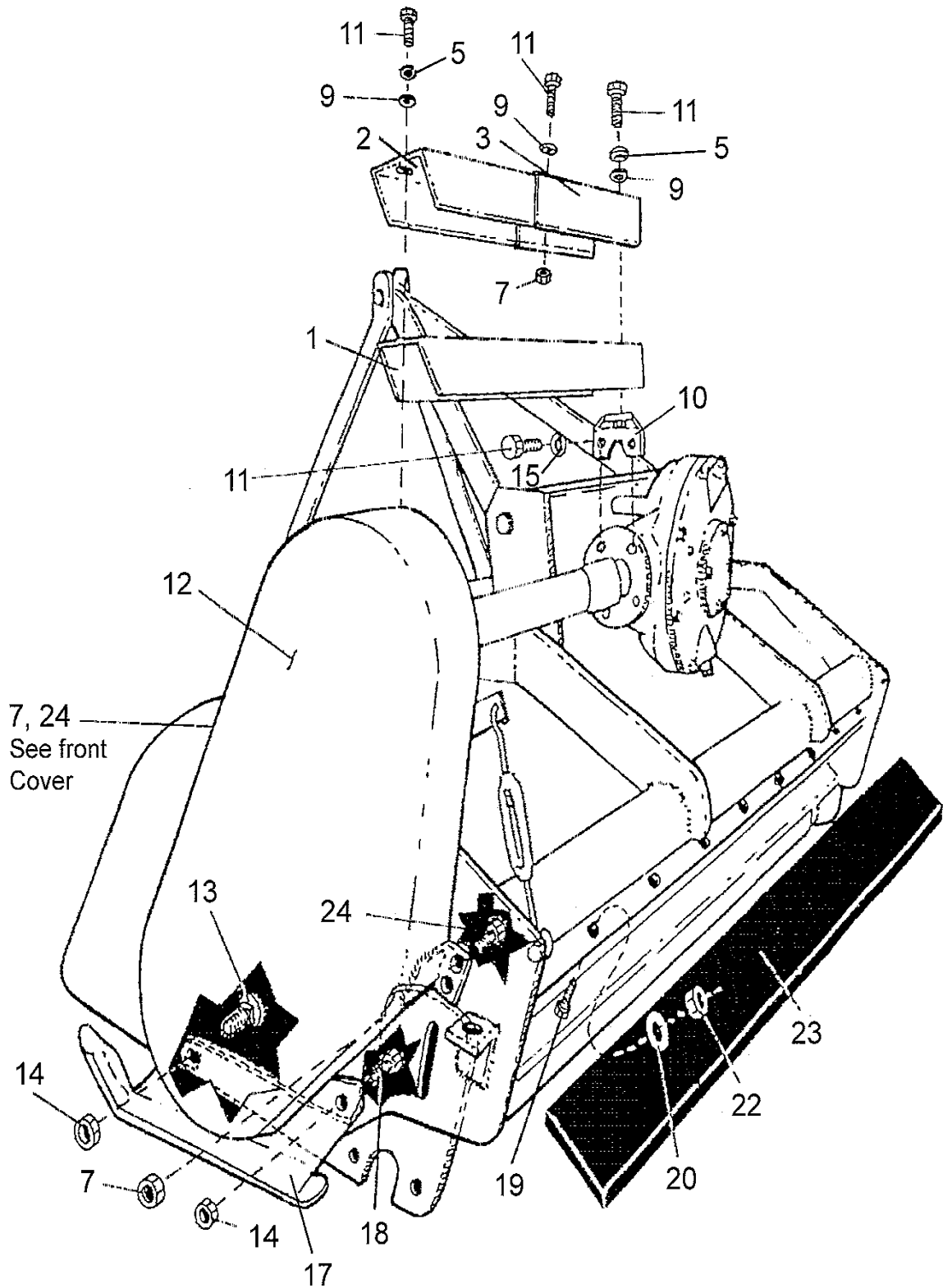

SHIELDS, SKID SHOES & RUBBER FLAPS

ITEM	PART NO.	QTY.	DESCRIPTION
1	106634	1	SHAFT SHIELD (60")
2	106636	1	LONG SHAFT SHIELD (74")
3	106635	1	SHORT SHAFT SHIELD (74") REVERSE ROTATION ONLY
5	00012101	2	LOCKWASHER
7	00015800	4	LOCKNUT
9	00011100	4	FLATWASHER
10	107413	1	SHIELD MOUNT BRACKET
11	00002000	6	BOLT
12	106632	1	PULLEY SHIELD
13	02886900	2	CARRIAGE BOLT
14	00001800	4	LOCKNUT
15	03101646	2	LOCKWASHER
17	106794	1	SKID SHOE (RH)
	106795	1	SKID SHOE (LH)
18	02030700	2	BOLT
19	10058000	9	BOLT (60")
		11	BOLT (74")
20	00024100	9	WASHER (60")
		11	WASHER (74")
22	02959924	9	NUT (60")
		11	NUT (74")
23	106172	1	REAR DEFLECTOR (60")
	106159	1	REAR DEFLECTOR (74")
24	00011400	2	BOLT

74" OFFSET A-FRAME ASSEMBLY

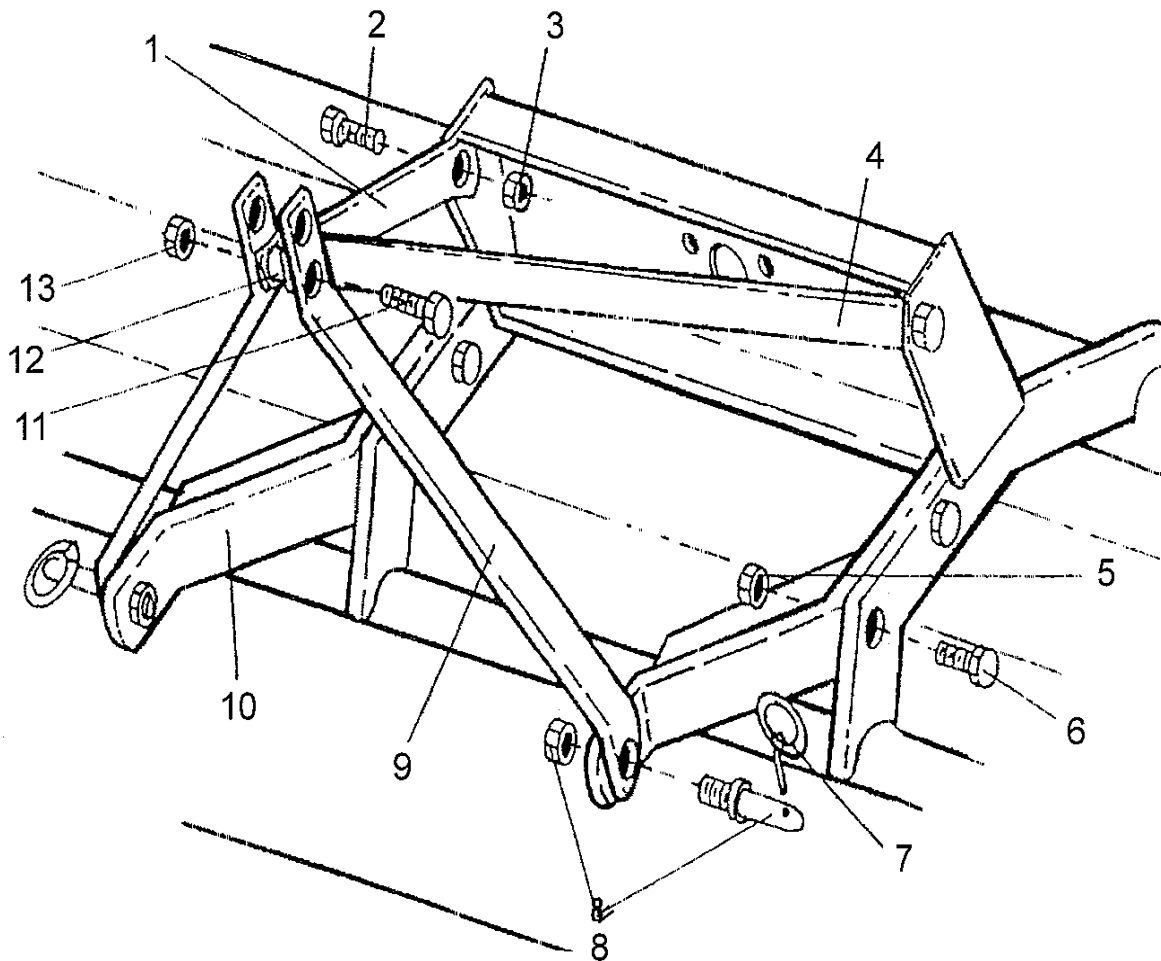

ITEM	PART NO.	QTY.	DESCRIPTION
1	106473	1	NARROW BRACE
2	02030700	2	BOLT
3	00001800	2	LOCKNUT
4	106472	1	WIDE BRACE
5	00695100	4	LOCKNUT
6	02045000	4	BOLT
7	2196	2	LYNCH PIN
8	00603500	2	CATEGORY I HITCH PIN, W/ NUT & LOCKWASHER
9	100022	2	FRONT STRUT
10	107412	2	HITCH ARM WELDMENT
11	00999418	1	BOLT
12	102803	1	STRUT SPACER
13	00001800	1	LOCKNUT

CASTER WHEEL PACKAGE

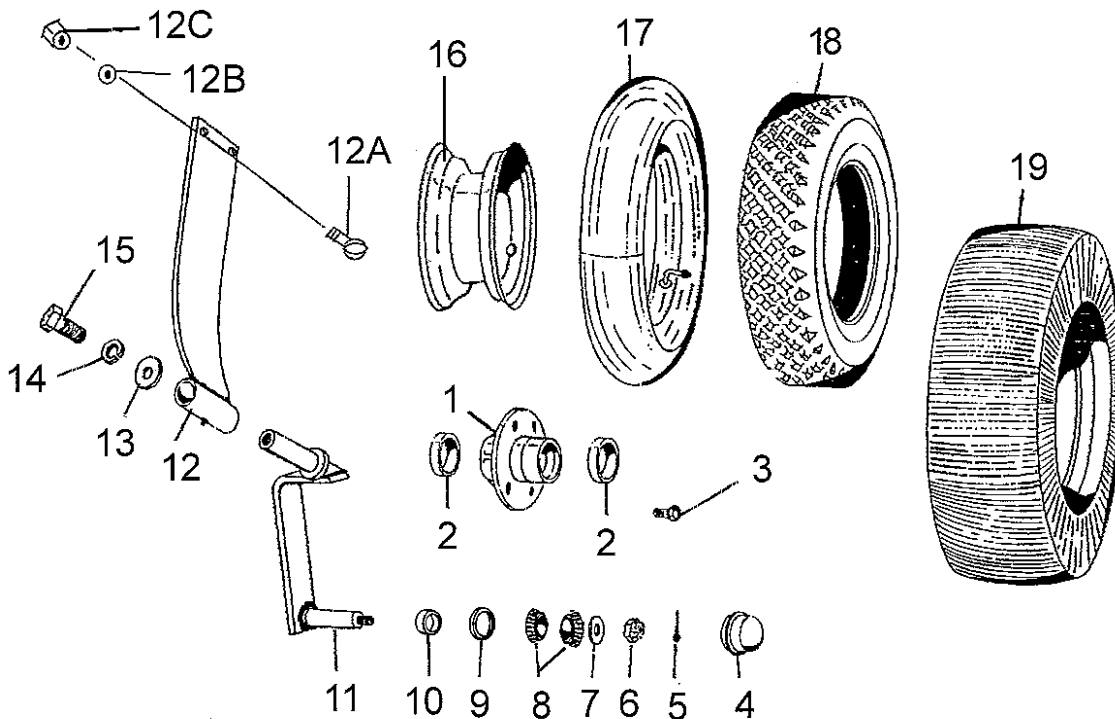

ITEM	PART NO.	QTY.	DESCRIPTION
1	000621	2	HUB WITH BEARING CUPS
2	000226	4	BEARING CUPS
3	000622	8	HUB BOLT (WITH ITEM 16)
	000554	8	HUB BOLT
	000520	8	LOCKWASHER
4	000247	2	HUB CAP
	000620	2	HUB COMPLETE (INCLUDES 1,8-10,4)
	702272	2	LOWER FORK ASY. (INCLUDES 1,4-11)
5	000123	2	COTTER PIN
6	000122	2	NUT
7	101780	2	WASHER
8	000225	4	BEARING CONE
9	000201	2	SEAL
10	000573	2	SPACER
11	100141	2	CASTER HALF FORK
12	701058	2	360 DEG. CASTER SOCKET WITH GREASE FITTING
12A	000142	4	BOLT
12B	000520	4	LOCKWASHER
12C	000170	4	NUT
13	103767	2	WASHER
14	000520	2	LOCKWASHER
15	000554	2	BOLT
16	000619	2	WHEEL (TUBE TYPE TIRE)
17	000623	2	TUBE
18	000618	2	TIRE (TUBE TYPE)
	000617	2	WHEEL, TIRE, TUBE ASY. (#S 16-18)
19	700280	2	LAMINATED TIRE / WHEEL ASY. (OPTIONAL)

QTY; SHOWN IS FOR TWO TAIL WHEEL ASY'S.

DRIVE SHAFT ASSEMBLY (P/N 00775472)

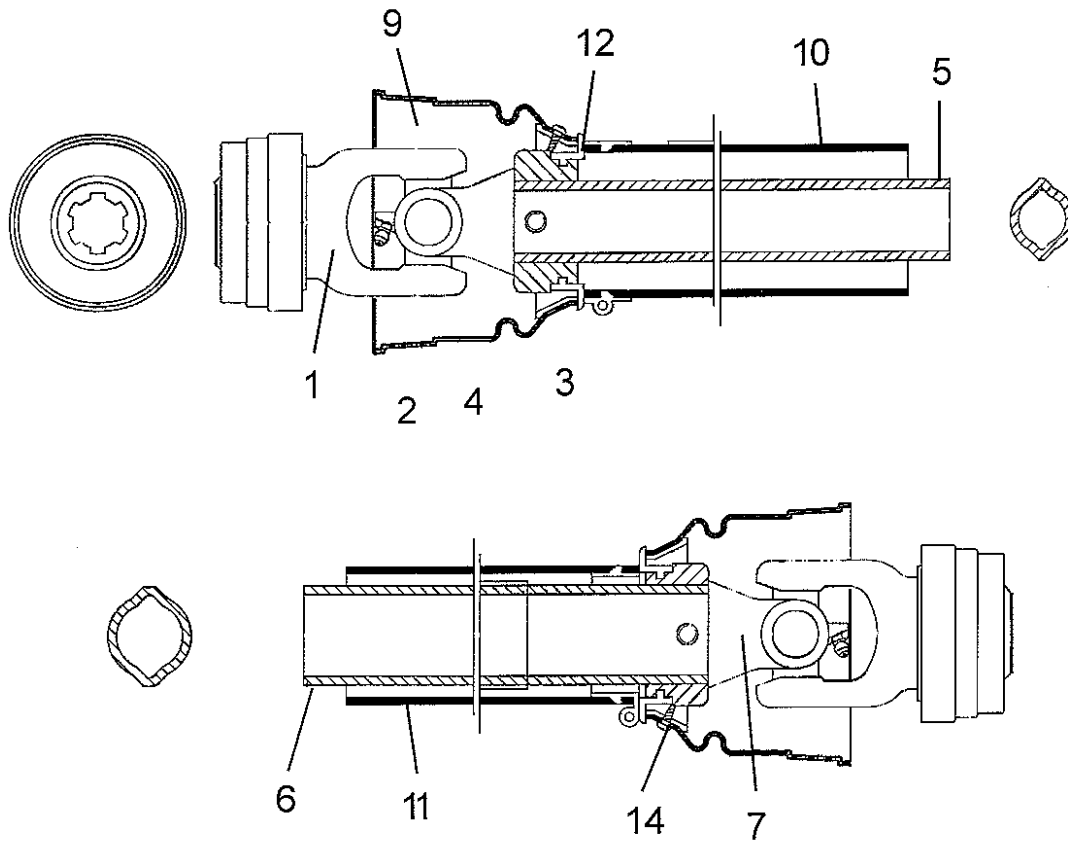

Item	Part No.	Qty	DESCRIPTION
	00775472		DRIVE SHAFT ASY.
1	007754752		YOKE, 1-3/8" - 6 SPLINE
2	007754762		CROSS & BEARING KIT
3	703623W2		SPRING PIN
4	007754771		INBOARD YOKE
5	3216401	1	INNER PROFILE
6	3216402	1	OUTER PROFILE
7	007754801		INBOARD YOKE
9	-----	2	SHIELD CONE
10	-----	4	OUTER SHIELD TUBE, OVAL
11	-----	4	INNER SHIELD TUBE, ROUND
12	3216406	2	BEARING RING
14	007592172		SCREW, (IN ITEMS 9)

Alamo Industrial

LIMITED WARRANTY

1. LIMITED WARRANTIES

- 1.01. Servis-Rhino warrants for one year from the purchase date to the original non-commercial, governmental, or municipal purchaser ("Purchaser") and warrants for six months to the original commercial or industrial purchaser ("Purchaser") that the goods purchased are free from defects in material or workmanship.
- 1.02. Manufacturer will replace for the Purchaser any part or parts found, upon examination at one of its factories, to be defective under normal use and service due to defects in material or workmanship.
- 1.03. This limited warranty does not apply to any part of the goods which has been subjected to improper or abnormal use, negligence, alteration, modification, or accident, damaged due to lack of maintenance or use of wrong fuel, oil, or lubricants, or which has served its normal life. This limited warranty does not apply to any part of any internal combustion engine, or expendable items such as blades, shields, guards, or pneumatic tires except as specifically found in your Operator's Manual.
- 1.04. Except as provided herein, no employee, agent, Dealer, or other person is authorized to give any warranties of any nature on behalf of Manufacturer.

2. REMEDIES AND PROCEDURES.

- 2.01. This limited warranty is not effective unless the Purchaser returns the Registration and Warranty Form to Manufacturer within 30 days of purchase.
- 2.02. Purchaser claims must be made in writing to the Authorized Dealer ("Dealer") from whom Purchaser purchased the goods or an approved Authorized Dealer ("Dealer") within 30 days after Purchaser learns of the facts on which the claim is based.
- 2.03. Purchaser is responsible for returning the goods in question to the Dealer.
- 2.04. If after examining the goods and/or parts in question, Manufacturer finds them to be defective under normal use and service due to defects in material or workmanship, Manufacturer will:
 - (a) Repair or replace the defective goods or part(s) or
 - (b) Reimburse Purchaser for the cost of the part(s) and reasonable labor charges (as determined by Manufacturer) if Purchaser paid for the repair and/or replacement prior to the final determination of applicability of the warranty by Manufacturer.The choice of remedy shall belong to Manufacturer.
- 2.05. Purchaser is responsible for any labor charges exceeding a reasonable amount as determined by Manufacturer and for returning the goods to the Dealer, whether or not the claim is approved. Purchaser is responsible for the transportation cost for the goods or part(s) from the Dealer to the designated factory.

3. LIMITATION OF LIABILITY.

- 3.01. MANUFACTURER DISCLAIMS ANY EXPRESS (EXCEPT AS SET FORTH HEREIN) AND IMPLIED WARRANTIES WITH RESPECT TO THE GOODS INCLUDING, BUT NOT LIMITED TO, MERCHANTABILITY AND FITNESS FOR A PARTICULAR PURPOSE.
- 3.02. MANUFACTURER MAKES NO WARRANTY AS TO THE DESIGN, CAPABILITY, CAPACITY, OR SUITABILITY FOR USE OF THE GOODS.
- 3.03. EXCEPT AS PROVIDED HEREIN, MANUFACTURER SHALL HAVE NO LIABILITY OR RESPONSIBILITY TO PURCHASER OR ANY OTHER PERSON OR ENTITY WITH RESPECT TO ANY LIABILITY, LOSS, OR DAMAGE CAUSED OR ALLEGED TO BE CAUSED DIRECTLY OR INDIRECTLY BY THE GOODS INCLUDING, BUT NOT LIMITED TO, ANY INDIRECT, SPECIAL, CONSEQUENTIAL, OR INCIDENTAL DAMAGES RESULTING FROM THE USE OR OPERATION OF THE GOODS OR ANY BREACH OF THIS WARRANTY. NOTWITHSTANDING THE ABOVE LIMITATIONS AND WARRANTIES, MANUFACTURER'S LIABILITY HEREUNDER FOR DAMAGES INCURRED BY PURCHASER OR OTHERS SHALL NOT EXCEED THE PRICE OF THE GOODS.
- 3.04. NO ACTION ARISING OUT OF ANY CLAIMED BREACH OF THIS WARRANTY OR TRANSACTIONS UNDER THIS WARRANTY MAY BE BROUGHT MORE THAN TWO (2) YEARS AFTER THE CAUSE OF ACTION HAS OCCURRED.

4. MISCELLANEOUS.

- 4.01. Proper Venue for any lawsuits arising from or related to this limited warranty shall be only in Guadalupe County, Texas.
- 4.02. Manufacturer may waive compliance with any of the terms of this limited warranty, but no waiver of any terms shall be deemed to be a waiver of any other term.
- 4.03. If any provision of this limited warranty shall violate any applicable law and is held to be unenforceable, then the invalidity of such provision shall not invalidate any other provisions herein.
- 4.04. Applicable law may provide rights and benefits to purchaser in addition to those provided herein.

KEEP FOR YOUR RECORDS

ATTENTION: Purchaser should fill in the blanks below for his reference when buying repair parts and/or for proper machine identification when applying for warranty.

Servis-Rhino Implement Model _____ Serial Number _____

Date Purchased _____ Dealer _____

ATTENTION:
READ YOUR OPERATOR'S MANUAL





TO THE OWNER/OPERATOR/DEALER

To keep your implement running efficiently and safely, read your manual thoroughly and follow these directions and the Safety Messages in this Manual. The Table of Contents clearly identifies each section where you can easily find the information you need.

The OCCUPATIONAL SAFETY AND HEALTH ACT (1928.51 Subpart C) makes these minimum safety requirements of tractor operators:

REQUIRED OF THE OWNER:

1. Provide a Roll-Over-Protective Structure that meets the requirements of this Standard; and
2. Provide Seatbelts that meet the requirements of this paragraph of this Standard and SAE J4C; and
3. Ensure that each employee uses such Seatbelt while the tractor is moving; and
4. Ensure that each employee tightens the Seatbelt sufficiently to confine the employee to the protected area provided by the ROPS.

REQUIRED OF THE OPERATOR

1. Securely fasten seatbelt if the tractor has a ROPS.
2. Where possible, avoid operating the tractor near ditches, embankments, and holes.
3. Reduce speed when turning, crossing slopes, and on rough, slick, or muddy surfaces.
4. Stay off slopes too steep for safe operation.
5. Watch where you are going - especially at row ends, on roads, and around trees.
6. Do not permit others to ride.
7. Operate the tractor smoothly - no jerky turns, starts, or stops.
8. Hitch only to the drawbar and hitch points recommended by the tractor manufacturer.
9. When the tractor is stopped, set brakes securely and use park lock, if available.



Keep children away from danger all day, every day...



Equip tractors with rollover protection (ROPS) and keep all machinery guards in place...



Please work, drive, play and live each day with care and concern for your safety and that of your family and fellow citizens.



AT 60/74 (06 - 05)

© 2005 Alamo Group Inc.