

Form No.
904071

216

Finger Wheel Rake

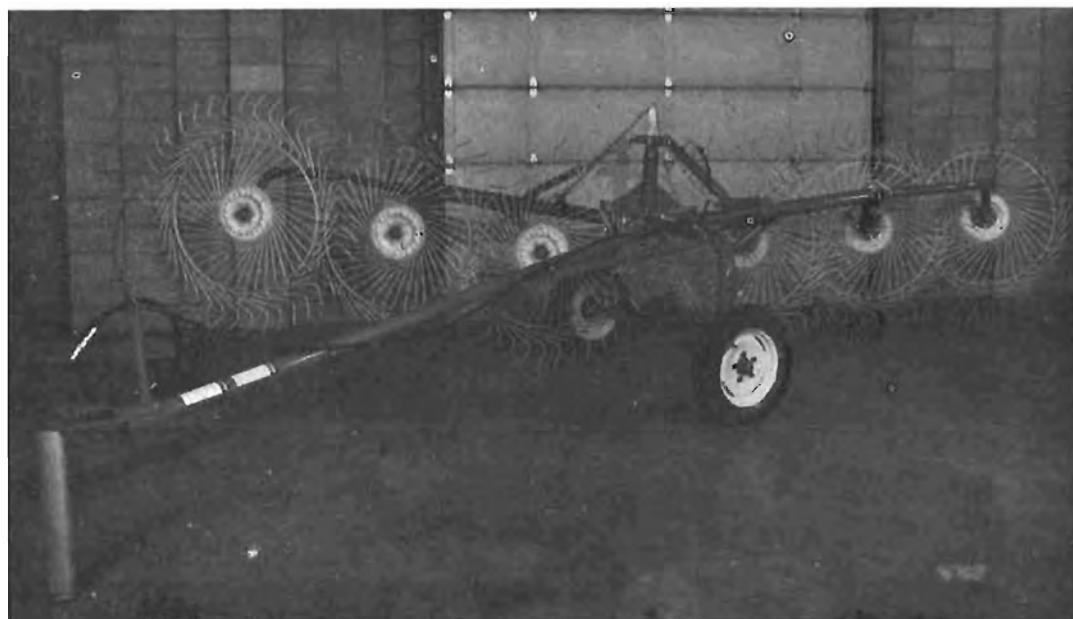

OPERATOR'S AND SERVICE PARTS MANUAL

GEHL® COMPANY

Warranty

GEHL COMPANY New Agricultural Equipment

GEHL Company (Incorporated), hereinafter referred to as **GEHL**, as manufacturer of quality machinery since 1859, warrants new **GEHL** machinery and/or attachments at the time of delivery to the original purchaser to be free from defects in material and workmanship if properly set up and operated in accordance with the recommendations set forth in **GEHL**'s Operator Manual.

GEHL's liability for any defect with respect to accepted goods shall be limited to repairing the goods at an authorized **GEHL** dealer or other **GEHL** designated location, or replacing them, as **GEHL** shall elect. The above shall be in accordance with **GEHL** warranty adjustment policies. **GEHL**'s obligation shall terminate twelve (12) months after the delivery of the goods to the original user or when the equipment is first put into use.

This warranty shall not apply to any machine or attachment which shall have been repaired or altered outside the **GEHL** factory or authorized **GEHL** dealership or in any way so as in **GEHL**'s judgment, to affect its stability or reliability, nor which has been subject to misuse, negligence or accident, nor to any machine or attachment which shall not have been operated in accordance with **GEHL**'s printed instructions or beyond the Company recommended machine rated capacity.

This warranty shall not be limited to items which are subject to the warranties of their respective manufacturers. Such items would include but would not be limited to engines, clutches, universal joints, knives, hydraulic components, bearings, tires, belts and other trade accessories.

EXCLUSION OF WARRANTIES

Except as otherwise expressly stated herein, **GEHL** makes no representation or warranty of any kind, express or implied, AND MAKES NO WARRANTY OF MERCHANTABILITY IN RESPECT TO ITS MACHINERY AND/OR ATTACHMENTS AND MAKES NO WARRANTY THAT ITS MACHINERY AND/OR ATTACHMENTS ARE FIT FOR ANY PARTICULAR PURPOSE. **GEHL** shall not be liable for incidental or consequential damages for any breach of warranty, including but not limited to inconvenience, rental or replacement equipment, loss of profits or other commercial loss. **GEHL** shall not be liable for, and the buyer assumes all liability for, all personal injury and property damage resulting from the handling, possession or use of the goods by the buyer.

No agent, employee or representative of **GEHL** has any authority to bind **GEHL** to any affirmation, representation or warranty concerning its machinery and/or attachments except as specifically set forth herein.

TABLE OF CONTENTS

Chapter	Description	Page
	Warranty	Inside Front Cover
1	Introduction	2
2	Specifications	3
3	Check Lists	5-7
4	Safety	8-9
5	Operation	10-13
6	Adjustments	14-15
7	Maintenance & Service	16
8	Set-up & Assembly	17-18
9	Decal Locations	19
10	Service Parts & Numerical Index	20-24
	Index	Inside Back Cover
	Standard Hardware Torque	Inside Back Cover

CHAPTER 1

INTRODUCTION

Your decision to purchase this piece of **GEHL** equipment was a good one. We are sure that your decision was strongly considered and that you are looking forward to many seasons of reliable performance from this machine.

We, as a Company, have invested a great deal of time and effort in developing our lines of agricultural and industrial equipment. The equipment you have purchased is built with a great deal of pride and designed to give you long life, efficient operation, durability and dependability. We ask that you study this manual carefully and familiarize yourself with the unit prior to using it; especially the information on safe operation contained in the **SAFETY** chapter. The information, contained within, was prepared for your assistance in preparing, adjusting, maintaining and servicing your machine. More importantly, this manual provides an operating plan for safe and proper use of your machine. Refer to the Table of Contents for an outline of this manual.

Modern machinery has become more sophisticated and with that in mind, GEHL Company asks that you read and understand the contents of this manual COMPLETELY and become familiar with your new machine, BEFORE you attempt to operate it. Furthermore, we recommend if this machine is resold that this Manual accompany the unit.

Typical Model & Serial No. Plate

MODEL NO. WR216
SERIAL NO. (Fill In)
GEHL COMPANY WEST BEND, WIS. 53095 U.S.A.

The Model and Serial numbers are on a decal plate located on the Main Frame.

"Right" and "Left" are determined from a position standing behind the Rake and facing the direction of travel.

Our wide Dealership network stands by to provide any assistance required, including genuine **GEHL** service parts. All parts should be obtained from or ordered through your **GEHL** Dealer. Give complete information about the part as well as the model number and serial numbers of your machine. Record numbers, in the spaces provided as a handy record for quick reference.

GEHL Company reserves the right to make changes or improvements in the design or construction of any part without incurring the obligation to install such changes on any unit previously delivered.

Throughout this manual, information is provided which is set in **bold type** and introduced by the word **NOTE**. **BE SURE to read carefully and comply with** the message or directive given. Following this information will improve your operating or maintenance efficiency, help you to avoid costly breakdowns or unnecessary damage and, extend your machine's life.

The **GEHL** Company, in cooperation with the Farm and Industrial Equipment Institute and the American Society of Agricultural Engineers, has adopted this **SAFETY ALERT SYMBOL**



to pinpoint characteristics which, if **NOT** properly followed, can create a safety hazard. When you see this symbol in this manual or on the unit itself, you are reminded to **BE ALERT!** Your personal safety is involved!

CHAPTER 2

SPECIFICATIONS

(All Dimensions are in Inches (Millimeters) Unless Otherwise Noted)

Model & Description	WR216 Wheel Rake
Working Width (Adjustable)	78 to 115 (1980 to 2920)
Transport Width	89 (2260)
Finger Wheel Diameter	55-1/8 (1400)
Number of Finger Wheels	Six
Number of Tines per Finger Wheel	Forty
Unit Weight (Approximate)	935 lb (425 kg)
Tire Size	5.00 x 15
Minimum Power Required	30 hp (22.3 kw)
Operating Speed	Up to 14 mph (9 kmh)

INTENTIONALLY BLANK

CHAPTER 3

CHECKLISTS

PRE-DELIVERY

After the Finger Wheel Rake has been completely set-up, the following inspections should be made before delivering it to the Customer. Check off each item after prescribed action is taken.

Check that:

- NO** parts of the unit have been damaged in shipment. Check for such things as dents and loose or missing parts; correct or replace components as required.
- Finger Wheel Rake has been completely and properly set-up according to the details in this manual
- All fasteners are in place and tightly secured.
- Hydraulic Cylinder, Hose and Fittings are **NOT** damaged leaking or loosely connected.
- All Grease Fittings and pivoting points have been properly lubricated; see Lubrication information in Maintenance & Service chapter of this manual.
- Serial Number of this unit are recorded on this page and page 2.

Dealership's Name

Dealer Representative's Signature

Date Checklist Filled-out

Serial Number

DELIVERY

The following Checklist is an important reminder of valuable information that **MUST** be passed on to the Customer at time the unit is delivered. Check off each item as you explain it to the Customer.

- Give the Operator's & Service Parts Manual to the Customer. Instruct Customer to **BE SURE** to read and completely understand its contents **BEFORE** operating the unit.
- Explain and review with Customer the **SAFETY** information in this manual.
- Explain the function and demonstrate the use of the Transport Lock Bar for the Hydraulic Lift Cylinder.
- Completely fill out the Owner's Registration, including Customer's signature, and return to the **GEHL** Company.

I acknowledge that above points were reviewed with me at the time of delivery.

Customer's Signature

Date Delivered

(Dealer's File Copy)

INTENTIONALLY BLANK
(To be removed as Dealer's File Copy)

CHAPTER 3

CHECKLISTS

PRE-DELIVERY

After the Finger Wheel Rake has been completely set-up, the following inspections should be made before delivering it to the Customer. Check off each item after prescribed action is taken.

Check that:

- ___ **NO** parts of the unit have been damaged in shipment. Check for such things as dents and loose or missing parts; correct or replace components as required.
- ___ Finger Wheel Rake has been completely and properly set-up according to the details in this manual
- ___ All fasteners are in place and tightly secured.
- ___ Hydraulic Cylinder, Hose and Fittings are **NOT** damaged leaking or loosely connected.
- ___ All Grease Fittings and pivoting points have been properly lubricated; see Lubrication information in Maintenance & Service chapter of this manual.
- ___ Serial Number of this unit are recorded on this page and page 2.

Dealership's Name

Dealer Representative's Signature

Date Checklist Filled-out

Serial Number

DELIVERY

The following Checklist is an important reminder of valuable information that **MUST** be passed on to the Customer at time the unit is delivered. Check off each item as you explain it to the Customer.

- ___ Give the Operator's & Service Parts Manual to the Customer. Instruct Customer to **BE SURE** to read and completely understand its contents **BEFORE** operating the unit.
- ___ Explain and review with Customer the **SAFETY** information in this manual.
- ___ Explain the function and demonstrate the use of the Transport Lock Bar for the Hydraulic Lift Cylinder.
- ___ Completely fill out the Owner's Registration, including Customer's signature, and return to the **GEHL** Company.

I acknowledge that above points were reviewed with me at the time of delivery.

Customer's Signature

Date Delivered

**(Pages 5 and 6 Have Been Removed
At Perforation)**

CHAPTER 4

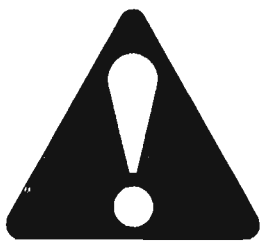

SAFETY



BEFORE ATTEMPTING TO OPERATE THIS EQUIPMENT, READ AND STUDY THE FOLLOWING SAFETY INFORMATION. IN ADDITION, ALWAYS MAKE SURE THAT EVERY INDIVIDUAL WHO OPERATES OR WORKS WITH THIS EQUIPMENT IS FAMILIAR WITH THESE SAFETY PRECAUTIONS.

GEHL Company always takes the operators and their safety into consideration when designing its machinery and guards exposed, moving parts for their protection; some areas, however, cannot be guarded or shielded in order to assure proper operation. In addition, the operator's manual and Decals on the machine itself warn of further danger and **MUST** be read and observed closely.

The safety alert symbol means **ATTENTION! BECOME ALERT! YOUR SAFETY IS INVOLVED!** It stresses an attitude of "HEADS UP" for safety and it will be found throughout this manual and on the machine itself.

Remember: The careful operator is the best operator. Most accidents are caused by human error. Certain precautions must be observed to prevent the possibility of injury or damage.

The words **CAUTION**, **WARNING** and **DANGER**, used herein and on the machine itself, signal three degrees of hazard. **CAUTION** is used for a general reminder of good safety practices or to direct attention to unsafe practices. **WARNING** is used to denote a specific potential hazard. **DANGER** is used to denote the most serious specific potential hazard.

Please read the rules listed below for safe operation **BEFORE** you operate this equipment.

MANDATORY SAFETY SHUTDOWN PROCEDURE

Work of any type on machinery is always more dangerous when the machine is operating. Therefore, unless otherwise expressly instructed to the contrary, **BEFORE** cleaning, adjusting, lubricating or servicing this machine, the following **MANDATORY SAFETY SHUTDOWN PROCEDURE** should **ALWAYS** be followed:

Shut the tractor engine off and remove the ignition key and take it with you before leaving the tractor seat to remedy the problem. **BE SURE** that tractor transmission is in "park" and/or lock the brakes.

Only when you have taken these precautions can you be sure it is safe to proceed. Failure to follow the above procedure could lead to death or serious bodily injury!

BEFORE transporting the Wheel Rake on a public highway, take the time necessary to place the Rake in the "Transport" position!

The Company does **NOT** sell replacement Tires. In addition, Tire mounting, service or inflation can be dangerous! Whenever possible, trained personnel should be called upon to service and/or mount Tires, following the Tire manufacturer's instructions. If you do **NOT** have such instructions, contact your tire dealer or the Company. In any event, follow the safety precautions described in the Maintenance & Service chapter!

ALWAYS follow state and local regulations regarding use of a safety chain and auxiliary lighting when towing farm equipment on a public highway! A safety chain should always be used to retain the connection between the towing and towed machines, in the event of separation of the primary attaching system! **BE SURE** to check with local law enforcement agencies for your own particular regulations. **ALWAYS** use a locking hitch pin for securing the implement drawbar to the tractor drawbar!

Wheel Rake operation is a function of the travel of the tractor; to **STOP** the Rake, **STOP** the tractor!

The operator **MUST** be seated on the tractor seat at all times while operating this machine!

BE SURE to review and comply with **ALL** Safety recommendations set forth in tractor operator's manual!



SAFETY

(Continued)



ALWAYS wear Safety Glasses with Side Shields when striking metal. In addition, it is recommended that a softer (non-chipable material) be used to cushion the blow. Failure to heed could result in serious injury to the eye(s) or other part(s) of the body.

Do NOT allow minors to operate or be near this machine unless properly supervised!

Do NOT allow personnel other than a qualified tractor operator near this machine!

NEVER use your hands to search for hydraulic fluid leaks; use a piece of cardboard. Escaping fluid under pressure can be invisible and can penetrate the skin and cause a serious injury! If any fluid is injected into your skin, see a doctor at once! Injected fluid **MUST BE** surgically removed by a doctor familiar with this type of injury or gangrene may result!

Do NOT wear loose or baggy clothing when operating this machine!

Do NOT perform work under the rake unless first engaging the Transport Bar to lock the cylinder in place.

REMEMBER! It is the owner's responsibility for communicating information on the safe use and proper maintenance of this machine!

CHAPTER 5

OPERATION



CAUTION: BEFORE starting the tractor engine and operating the Finger Wheel Rake for the first time, review and comply with ALL SAFETY recommendations set forth in the SAFETY chapter of this manual.

EMERGENCY SHUTDOWN

In an emergency or in case material or a foreign object becomes lodged in or between the Finger Wheels, stop Rake operation **IMMEDIATELY** by stopping tractor forward movement.



CAUTION: Following the MANDATORY SAFETY SHUTDOWN PROCEDURE, shut the tractor engine off and remove the ignition key and take it with you before leaving the tractor seat to remedy the problem.

GENERAL INFORMATION (Fig. 5-1)

The **GEHL** 216 Finger Wheel Rake is a trail-behind ground-driven Rake suitable for raking hay, straw, grass, etc. It features inflated rubber Tires mounted in the middle of the Main Frame. Three Finger Wheel assemblies are provided ahead of and behind the Tires to maintain proper balance. Through appropriate positioning of the Drawbar Width Adjustment Rod and both Wheels Axles, the operating width of the Rake can be adjusted from 78 to 115" (1980 to 2920 mm).

As a trail-behind Rake, the model 216 is ideal for particular field conditions where obstacles, such as trees, may be encountered. The Rake continues to turnout regular windrows, even through the curves and around obstacles.

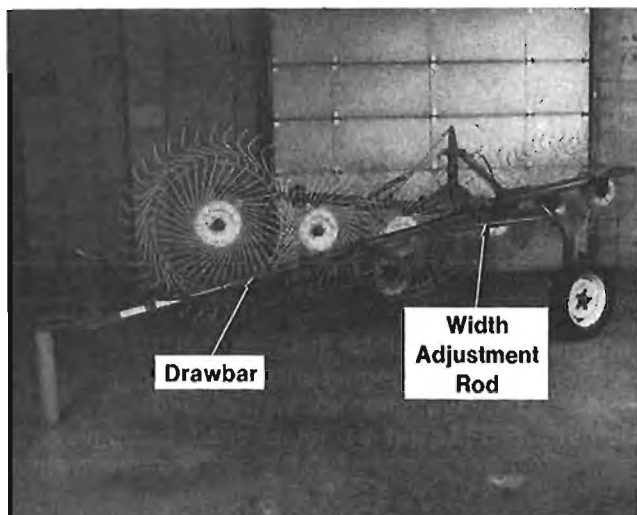

Fig. 5-1: WR216 Rake in Transport Position

MOUNTING TO TRACTOR (Fig. 5-2)

It is advisable to attach the 216 Rake to the swinging hitch drawbar of the tractor with a locking hitch pin at a height of 16" (405 mm) from the ground. For tractors that do **NOT** have a swinging hitch drawbar, the Rake Drawbar can be hooked onto the tractor 3-point linkage drawbar in the same manner, provided it is stabilized from moving sideways. Fix the height of the 3-point linkage drawbar with the tractor's hydraulic control lever stop, as applicable. After the Drawbar is connected, plug the Hydraulic Lift Control Cylinder Hose Quick Disconnect into an appropriate remote outlet on the tractor.

Proceed to adjust the Rake width, following details in the Adjustments chapter or place the Rake in the Transport position, for highway travel, following details under the next topic.

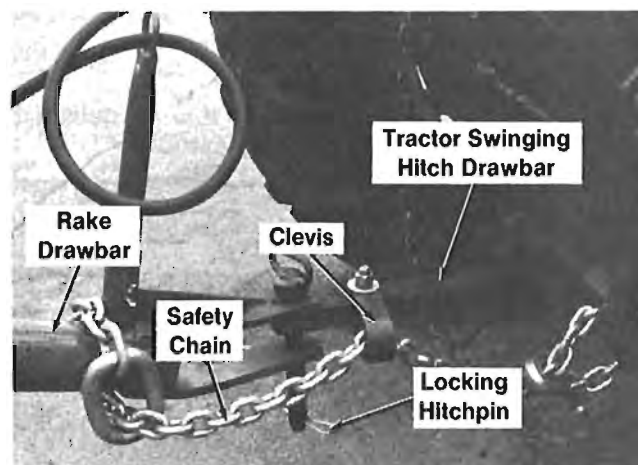

Fig. 5-2

TRANSPORTING (Figs. 5-2, 5-3 & 5-4 & see Fig. 5-1)



CAUTION: BEFORE transporting the Rake over a public highway, make sure that the Rake is attached to the tractor with a locking hitch pin and that the Finger Wheels are raised to the transport position and that the Lift System is locked in the Transport position.

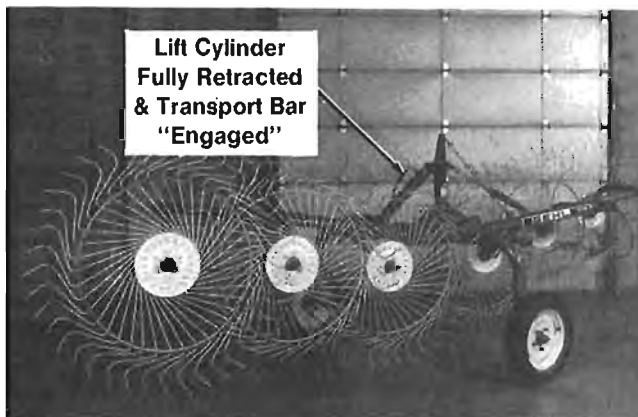

Fig. 5-3

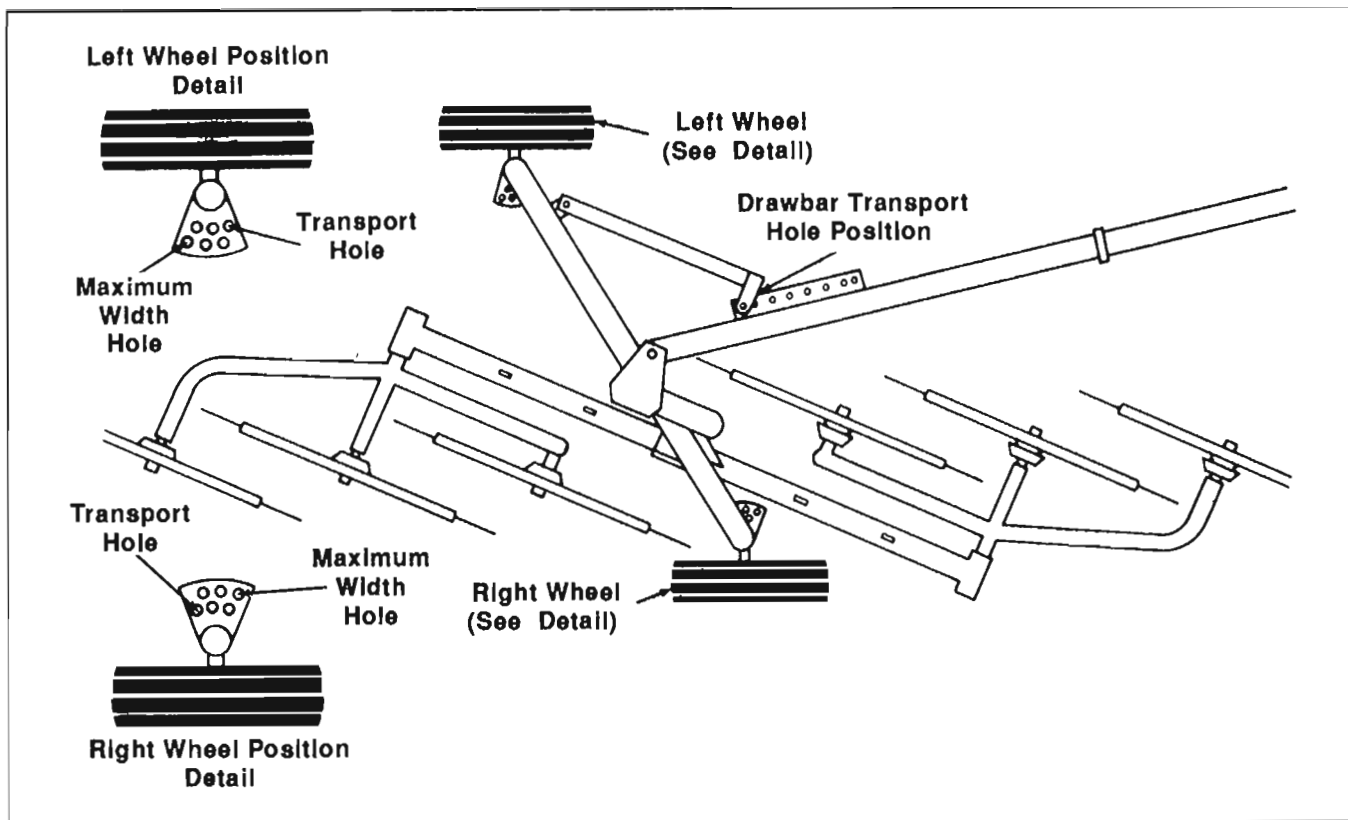

Fig. 5-4: Rake Wheels & Drawbar Adjusted to "Transport" Positions

For transporting the Rake on a public highway, first bring the Finger Wheels to their maximum raised position by fully retracting the Hydraulic Lift Cylinder. Then, install the Transport Bar over the Cylinder Rod Pin and secure it with the Lock Pin. Next, reposition the Width Adjustment Rod to adjust the Drawbar to the Transport position and lock it in this position. Then, readjust the Wheel Axles to their Transport positions.



CAUTION: When desired or where required, a safety chain should also be obtained and used as a secondary coupling between the tractor and Rake Drawbar. Use only a steel chain. Do NOT use a nylon strap.

RAKE OPERATION (Figs. 5-4 thru 5-11)

The 216 Finger Wheels will rotate to the right (clockwise) and the crop will traverse from right to left. Finger Wheel pressure on the ground is most important to achieving clean raking. If too much pressure is applied against the ground, unnecessary dirt and trash will be brought into the windrow. Although the

Rake has a considerably large working width, when working in grass or hay, it is recommended that the windrow is made **NO** larger than the pickup capacity of the baler or harvester. In straw or other light crops, the maximum width can be utilized.

The most satisfactory method for starting to rake a crop is to start in the middle of the field and then to turn around to the left. To make the first windrow, place both Wheels of the Rake in their hole positions closest to Transport and the Drawbar in the second hole position from Transport. After the first pass, raise the Finger Wheels. Turn around to the left and lower the Finger Wheels. Then, rake the second and first pass into one windrow. After this pass is made, another space will be opened. For the subsequent windrows, set the Rake to a wider operating width and continue raking the field. At the end, rake the headlands.

NOTE: If the hay crop has been cut and conditioned with a Mower Conditioner, the Rake should be initially set to maximum raking width.

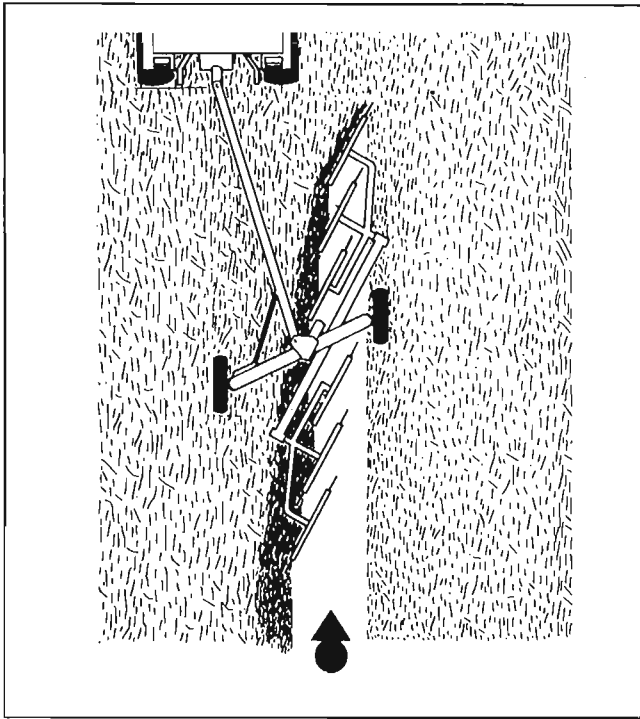

Fig. 5-5

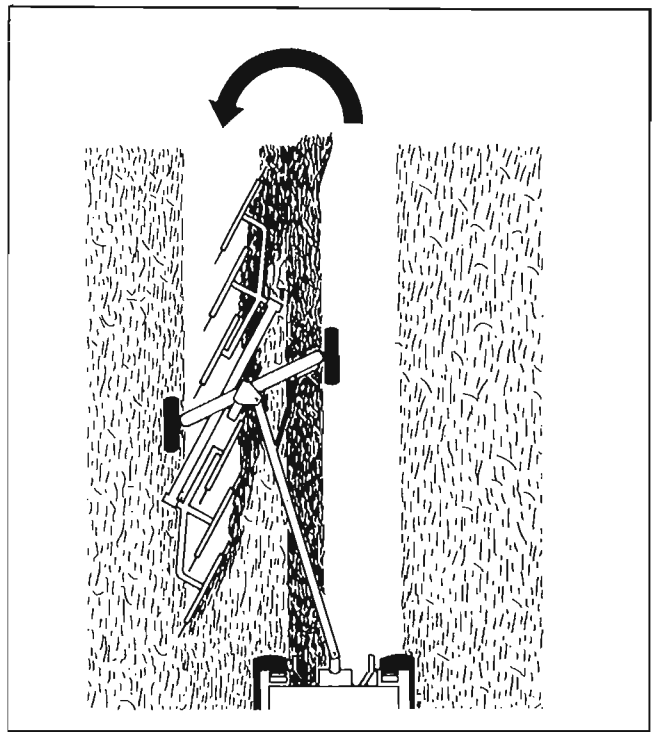

Fig. 5-6

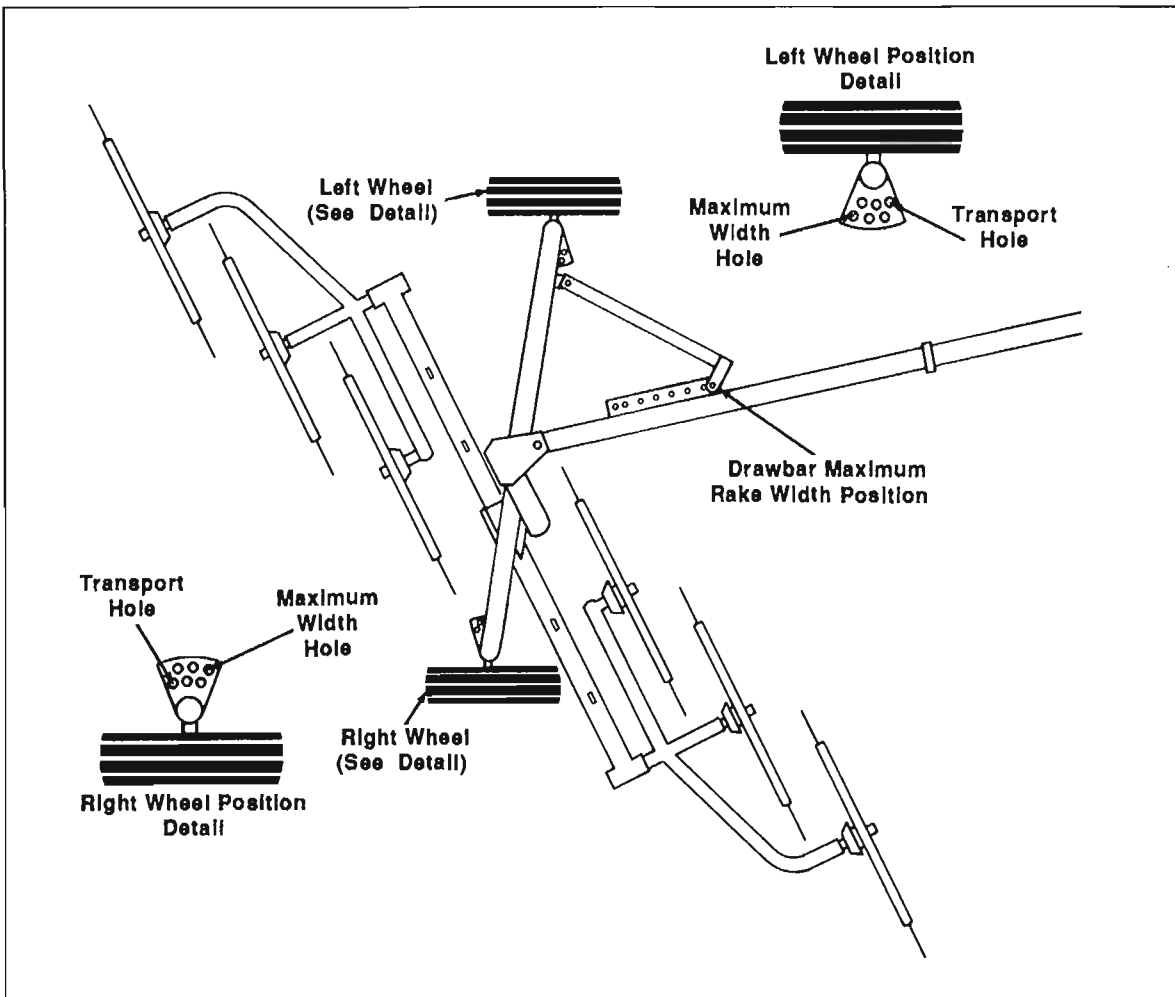

Fig. 5-7: Rake Wheels & Drawbar Adjusted for Widest Operating Width

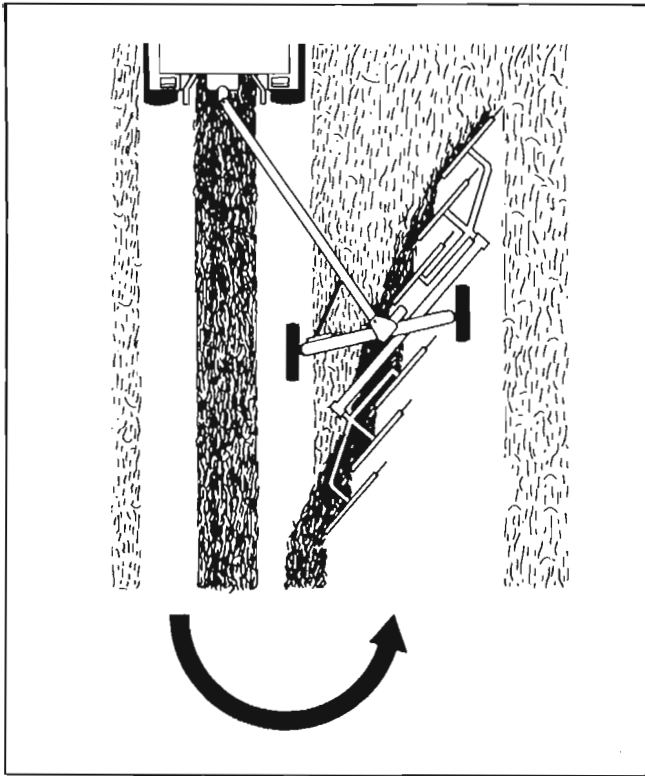

Fig. 5-8

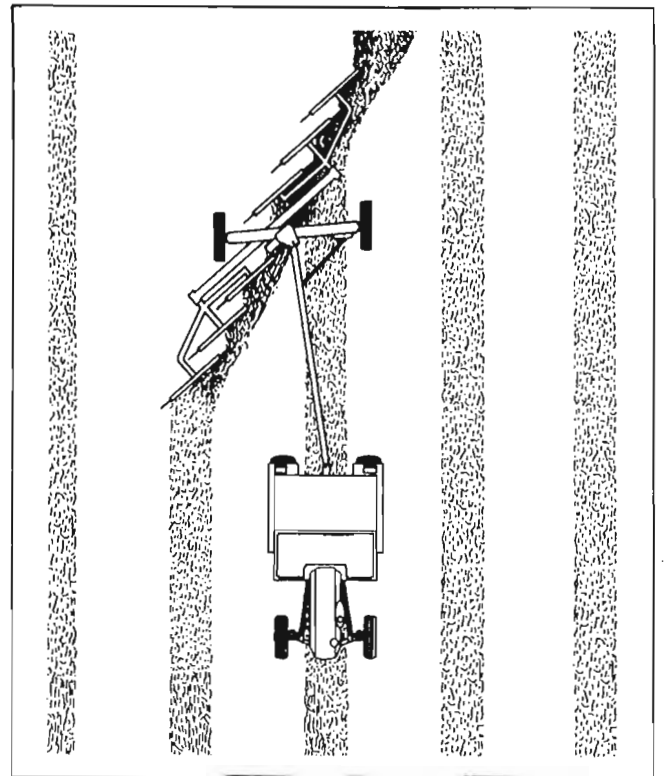

Fig. 5-10: Raking Conditioned Crop

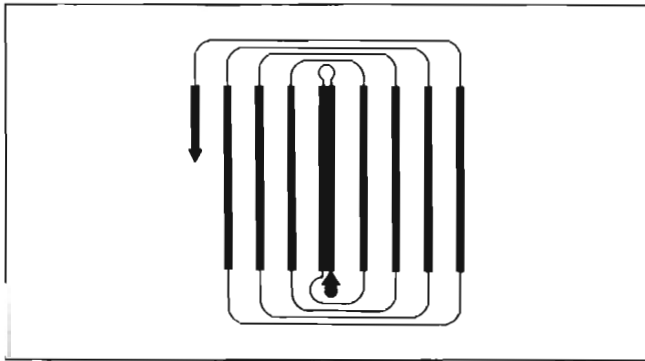

Fig. 5-9: Non-conditioned Cut Crop Raking Pattern

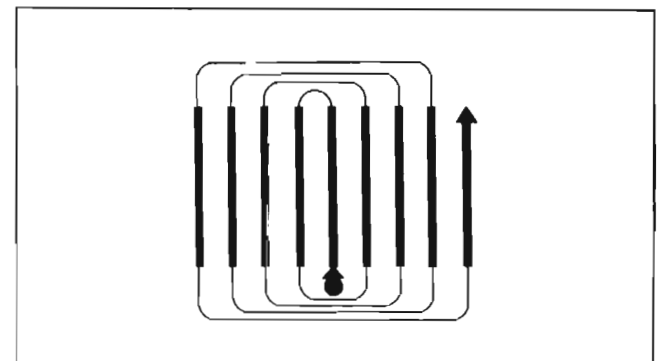

Fig. 5-11: Conditioned Crop Raking Pattern

CHAPTER 6

ADJUSTMENTS



CAUTION: BEFORE proceeding to make any adjustments on the Finger Wheel Rake, **BE SURE** to follow the **MANDATORY SAFETY SHUTDOWN PROCEDURE** and to place the tractor transmission in park and/or lock the brakes, to shut off the engine and, remove the ignition key and take it with you **BEFORE** leaving the tractor seat.

GROUND PRESSURE (Fig. 6-1)

NOTE: Proper Finger Wheel pressure on the ground is an important factor for achieving clean raking. Too much pressure will cause undue stress on the Finger Wheel Tines and cause unnecessary dirt and trash to be brought into the windrow.

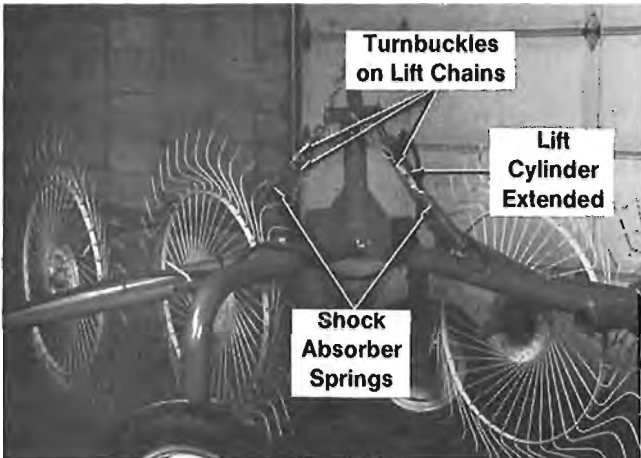

Fig. 6-1

The Hydraulic Lift Cylinder is used to move the Finger Wheels from their Transport to the Operating position. Finger Wheel ground pressure is adjusted by means of Turnbuckle Links connected to the Lift Chains. Adjusting the Turnbuckle, to shorten it, reduces the ground pressure. Making the Turnbuckle longer increases the ground pressure. If the desired pressure can NOT be achieved by adjusting the Turnbuckle, select a different Chain Link anchor point and repeat the Turnbuckle adjustment process. While raking, the ground pressure is correct if the crop is raked away cleanly. Too great a ground pressure will tend to distort the windrow, cause dirt to get into the crop and cause undue Tooth wear.

WORKING WIDTH (Figs. 6-2 & 6-3)

The working width of the Rake is established by first adjusting the position of the Drawbar, with respect to the tractor, and also by setting the positions of both Wheels. For transporting the Rake, the Main Frame should be linked to the Drawbar in one of the two hole positions closest to the Main Frame. Likewise, for transporting, both Wheels should be set in respective hole positions that place both Wheels as close as possible to parallel with the Front and Rear Frames. Setting the Drawbar in the hole position farthest from the Transport hole and the Wheels in the hole positions farthest from the Transport hole positions will enable the widest raking width. Six intermediate Drawbar adjustment positions and four intermediate Wheel positions are provided. Whenever the working width is adjusted, establish the required tractor position first and then, adjust the Wheels.

It is recommended that the Rake Drawbar be attached to the swinging hitch of the tractor. For optional hookup to the 3-point linkage drawbar of the tractor, the Rake can be connected in a hole farther to the right to obtain a better tractor-Rake tracking and alignment.

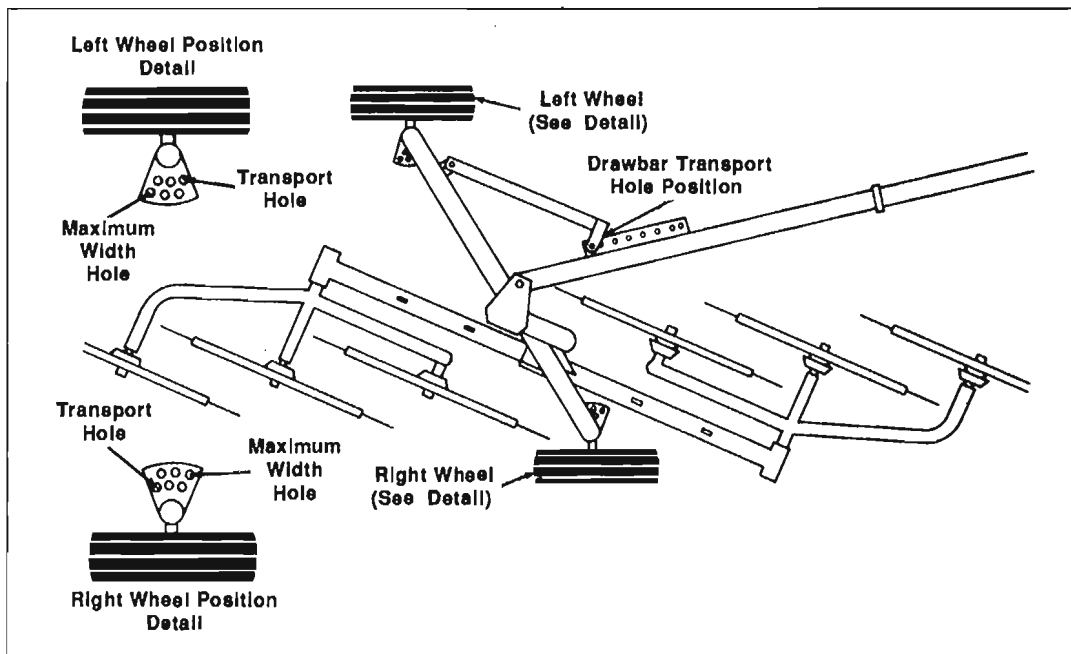

Fig. 6-2: Rake Wheels & Drawbar Adjusted to "Transport" Positions

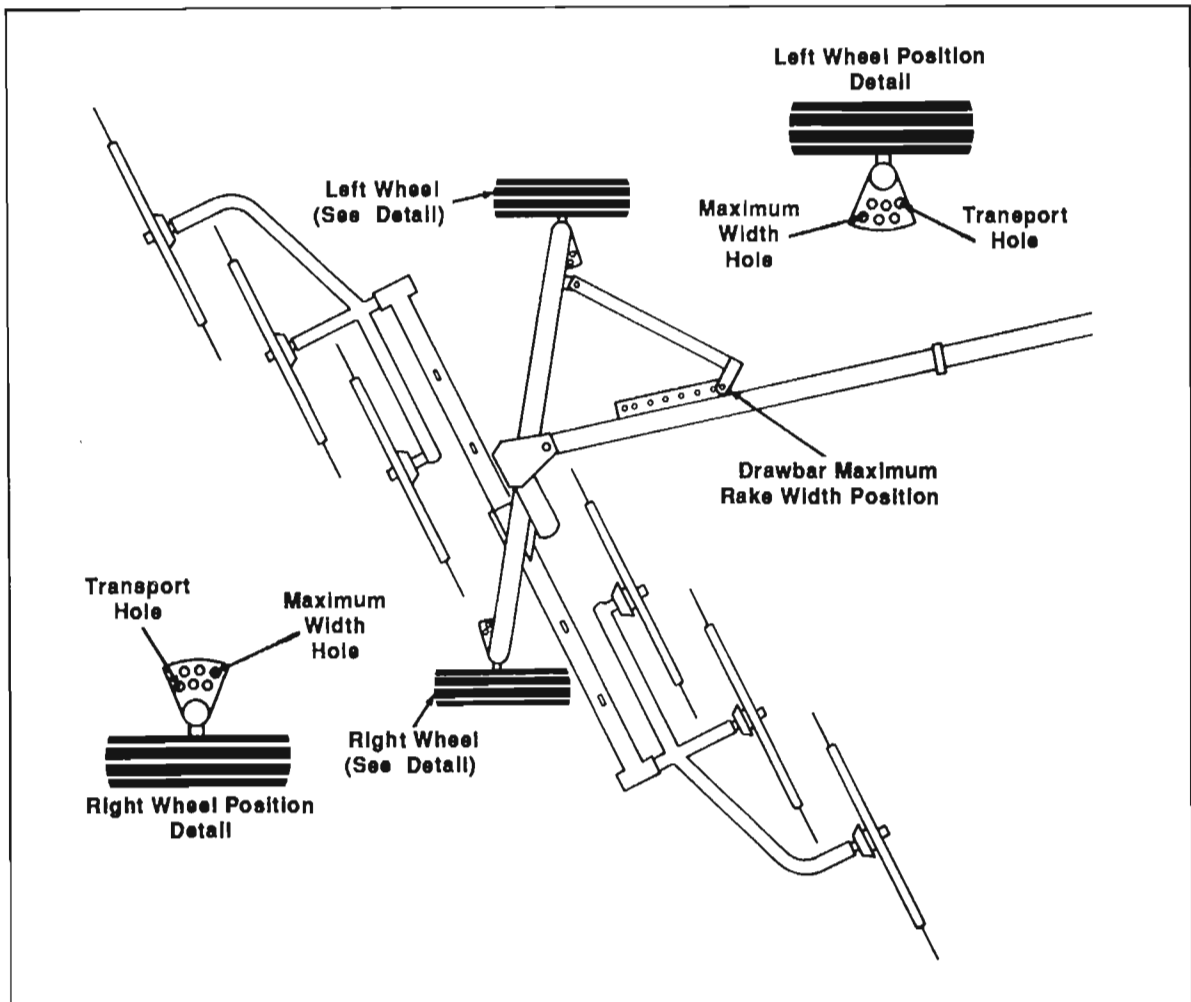

Fig. 6-3: Rake Wheels & Drawbar Adjusted for Widest Operating Width

CHAPTER 7

MAINTENANCE & SERVICE

HARDWARE (Fig. 7-1)

After the first hour of operation, check all attaching hardware, especially in the areas of the Tine anchor bolts and Finger Wheel Hubs. Hardware torques should be checked on a routine basis after every 10 hours of operation.

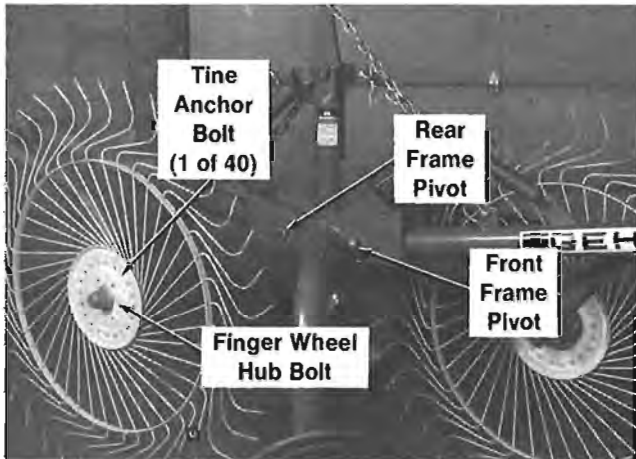

Fig. 7-1

LUBRICATION (Figs. 7-1, 7-2 & 7-3)

To maintain proper operation, all revolving parts and hinge points **MUST** move smoothly and be kept well lubricated.

Oil the following points at regular 10 hour intervals:

1. Drawbar Pivot
2. Lift Plate Pivot points
3. Front Frame Pivot
4. Rear Frame Pivot
5. Wheel Arm Pivots (2 Places)
6. Arm Lock Mechanisms (2 Places)

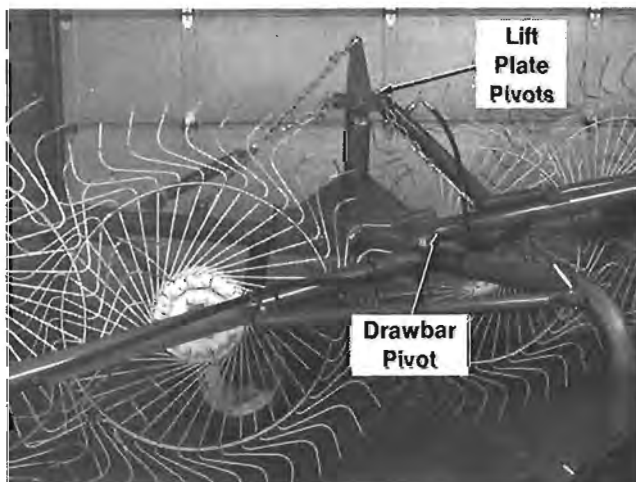

Fig. 7-2

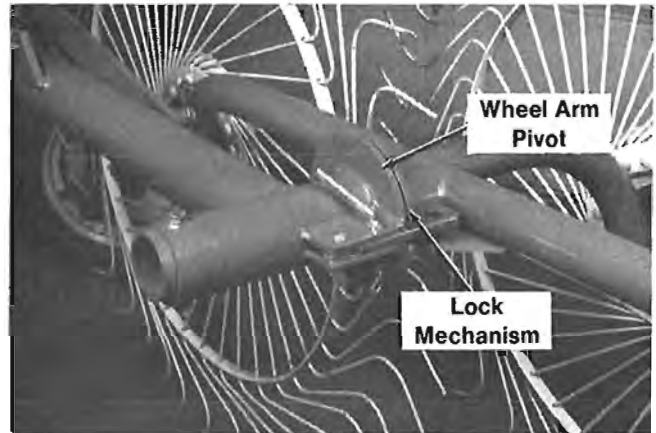

Fig. 7-3

TIRES & WHEELS



CAUTION: Our Company does NOT sell replacement Tires. In addition, Tire mounting, repair and replacement should **ONLY** be attempted by a qualified tire manufacturer's representative or by properly trained personnel following the tire manufacturer's instruction. If you do NOT have such instructions, contact your tire dealer or the Company.

Check the Rake Tire pressure after every 50 hours of operation. Tires should be inflated to 28 PSIG (196 kPa). Wheel Bolt torques should also be checked after every 50 hours of operation and tightened with 110 ft-lb (150 Nm) torque.



WARNING: Inflating or servicing tires can be dangerous. Whenever possible, trained personnel should be called to service and/or mount tires. In addition, do NOT place fingers on tire bead during inflation; serious injury or amputation could result! In any event, to avoid possible fatal or serious injury, follow the safety precautions below:

BE SURE the rim is clean and free of rust.

Lubricate both the tire beads and rim flanges with a soap solution. Do **NOT** use oil or grease.

Use a clip-on tire chuck with a remote hose and gauge which allows you to stand clear of the tire while inflating it.

NEVER inflate beyond 35 PSI (240 kPa) to seat the beads. If beads have **NOT** seated by the time the pressure reaches 35 PSI, deflate the assembly, reposition the tire on the rim, relubricate both parts and reinflate it. Inflation pressure beyond 35 PSI with unseated beads may break the bead or rim with explosive force sufficient to cause fatal or serious injury.

After seating the beads, adjust the inflation pressure to the recommended operating pressure listed.

Do **NOT** weld, braze, or otherwise attempt to repair and use a damaged rim.

CHAPTER 8

SET-UP & ASSEMBLY

NOTE: These assembly procedures should be performed inside an enclosed workshop equipped with an overhead hoist to facilitate lifting some of the heavier components or otherwise another person (or persons) should be available to assist in lifting. To facilitate set-up & assembly, it is advisable that this procedure be accomplished in the manner outlined.

UNCRATING

The Finger Wheel Rake is shipped from the factory packaged in a plywood crate. Begin setup by removing all of the components from the crate and laying them out in an orderly fashion.

RAKE ASSEMBLY (Figs. 8-1 thru 8-7)

After the components have been removed from the shipping crate, refer to the exploded-view parts illustrations, parts lists and the photographs provided and proceed as follows:

WARNING: ALWAYS wear Safety Glasses with Side Shields when striking metal. In addition, it is recommended that a softer (non-chipable material) be used to cushion the blow. Failure to heed could result in serious injury to the eye(s) or other part(s) of the body.

1. Properly orient and insert an Axle Hub into the mating socket on each side of the Main Frame. Secure each Axle with a Lock Pin and 4mm Hairpin Cotter Pin. Then, attach a Wheel and Tire assembly to each Wheel Hub with (6 each side) Lug Nuts.

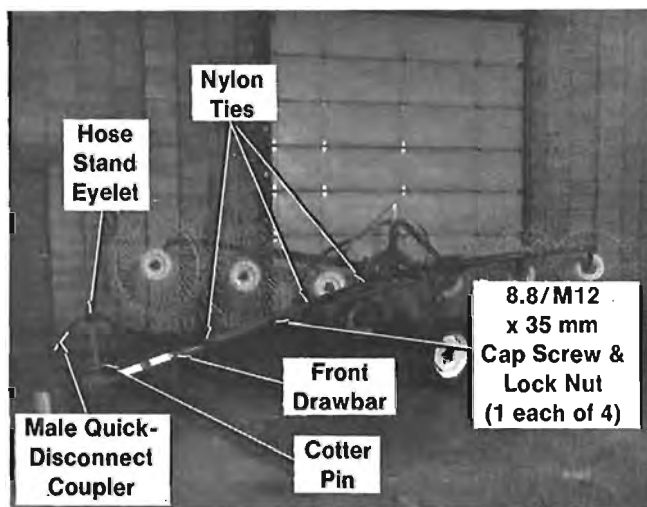

Fig. 8-1

2. Raise and properly support the Main Frame and Wheels, in the operating position. Then, properly orient and attach the Front and Rear Frames to the Main Frame with (1 each) M24 x 160mm Bolt and M24 Lock Nut.

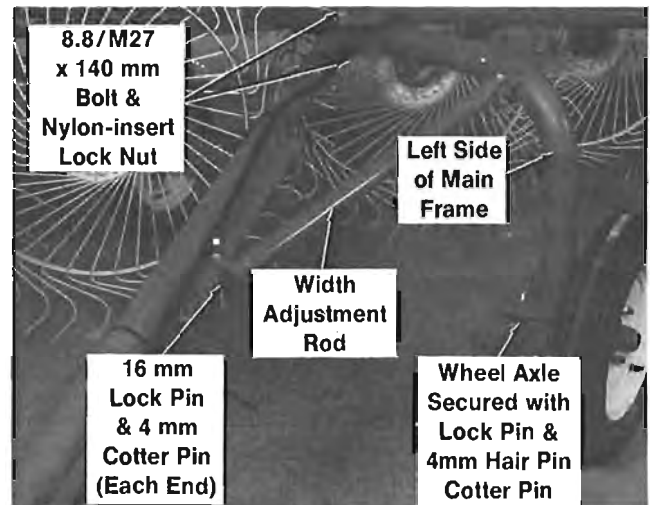

Fig. 8-2

3. Generously lubricate the pipes of both Wheel Arms with grease. Then, properly orient (so that the three Finger Wheel Supports angle downward) and install one Wheel Arm into the Hub of the Front Frame and the other Wheel Arm into the Hub of the Rear Frame. Secure each assembly by installing the Rake Arm Ring and an 8.8/M12 x 120 mm Cap Screw and Lock Nut. Then, engage the Latches and install Lock Pins and Hairpin Cotter Pins.
4. Properly orient and preassemble the Front Drawbar to the Rear Drawbar with (4 each) 8.8/M12 x 35mm Cap Screws and M12 Lock Nuts. Then, attach the Rear Drawbar to the Main Frame with the 8.8/M27 x 140mm Bolt and Nylon-insert Lock Nut.
5. Properly orient and attach the Width Adjustment Rod between the Main Frame and the Rear Drawbar. Secure the Rod with a 16mm Lock Pin and 4mm Hairpin Cotter Pin on one end and an M20 x 90 mm Cap Screw and Lock Nut on the other end.

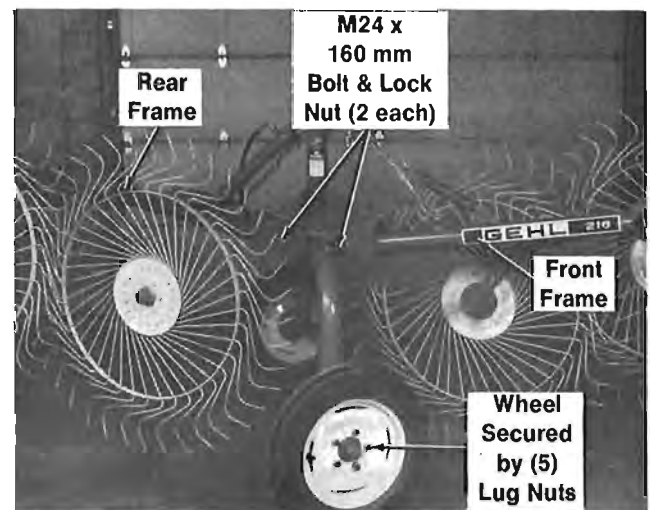

Fig. 8-3

- Properly orient and attach the Lift Cylinder between the Rear Frame and the Lift Plate. Anchor the Cylinder Rod to the Lift Plate with Cylinder Rod Pin and the anchor end of the Cylinder to the Rear Frame with the Cylinder Anchor Pin and secure both Cylinder Pins with a 4mm Cotter Pin.
- Using a Shackle on each end, properly orient and attach the one Turnbuckle and Chain assembly between the top of the Lift Plate and the closer Tab on the Front Frame.

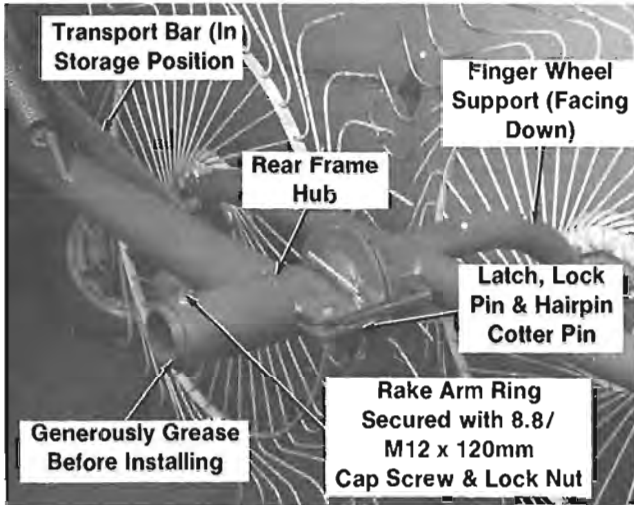

Fig. 8-4

- Hook one of the Lift Springs into the other Tab on the Front Frame and the other Lift Spring into the Tab on the Rear Frame. Then, attach the Turnbuckles to the other ends of both Springs and anchor the Chains with Shackles to the appropriate sides of the Lift Plate.
- Install the Hose Stand into the welded-on Hub on the Front Drawbar and secure it with a Cotter Pin. Then, route the Cylinder connection end of the Hydraulic Hose thru the Eyelet in the Hose Stand, along the Drawbar and up to the Lift Cylinder. Connect the Hose to the Lift Cylinder port using pipe sealing compound or teflon tape. After the Hose is connected, draw-back (toward the tractor connection end of the Drawbar) the extra slack and anchor the Hose to the Drawbar using the several of the Nylon Ties provided.

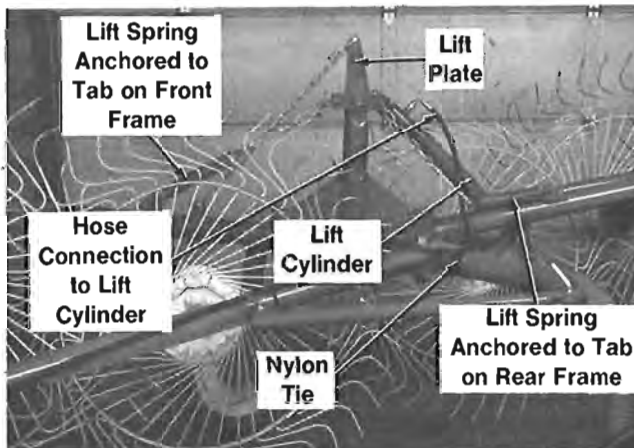

Fig. 8-5

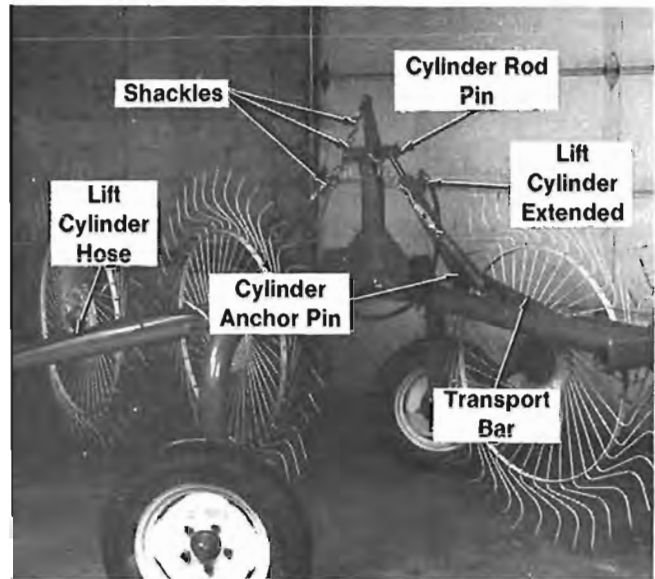

Fig. 8-6

- Connect the Rake to the tractor drawbar and plug the Lift Cylinder Hose into a remote outlet on the tractor.

NOTE: A standard ISO Male Quick Disconnect Coupler is furnished with the Rake. As required, and to match the Female Disconnect port on your particular model tractor, the appropriate Quick Disconnect coupler may have to be purchased locally.

- Start the tractor engine and operate the remote outlet control to fully retract the Lift Cylinder. Then, shut the tractor off and install the Transport Bar over the Rod Anchor Pin and secure, thru the hole in the Lift Rod and install the Hairpin Cotter Pin to lock the Lift Cylinder in the fully retracted position and remove the weight from the cylinder.
- Install the Hubs and Finger Wheels onto the Spindles of the Rake Arms as illustrated. Readjust the Lift Chains per details in the Adjustment chapter of this manual.

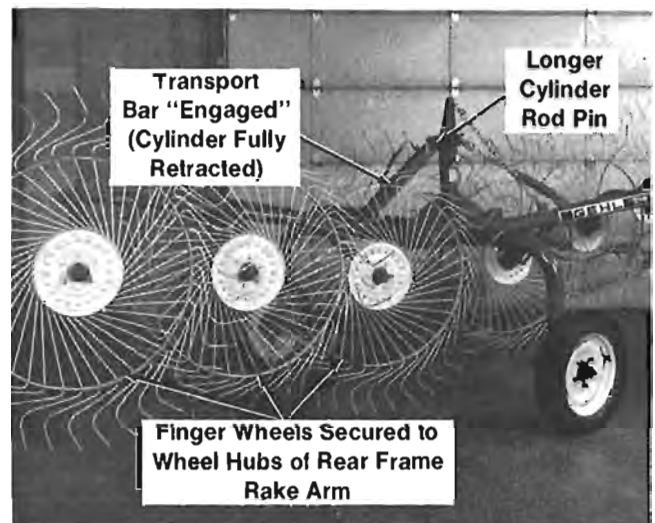

Fig. 8-7: Rake Assembly Raised & Locked in "Transport" Position

CHAPTER 9

DECAL LOCATIONS

GENERAL INFORMATION

Decal Locations information is provided to assist in the proper selection and application of new decals, in the event the original decal(s) become(s) damaged or the machine is repainted. Refer to the listing for the illustration reference number, part number, description and quantity of each decal provided in the Kit. Refer to the appropriate illustration(s) for replacement location(s).

To insure proper selection of the correct replacement decal(s), compare all of the various closeup location photographs to your machine, before starting to refinish the unit. Then, circle each pictured decal (on or otherwise applicable to your machine) while checking-off its part number in the listing. After you have verified all the decals needed for replacement, place any unnecessary decals aside for disposal.

NEW DECAL APPLICATION

Surfaces **MUST** be free from dirt, dust, grease and other foreign material before applying the new decal. To apply a solid-formed decal, remove the smaller portion of the decal backing paper and apply this part of the exposed adhesive backing to the clean surface while maintaining proper position and alignment. Peel the other portion of the backing paper off slowly while applying hand pressure to smooth-out decal surface.



CAUTION: ALWAYS observe Safety Rules shown on Decals. If Decal(s) become(s) damaged, or if the unit is repainted, replace the Decal(s). If repainting, **BE SURE** that ALL Decals from the Kit(s), which apply to your machine, are affixed to your unit.

The Decal Kit for the WR216 Finger Wheel Rake is 089265. The Kit includes the following:

Ref. No.	Part No.	Description & Quantity
1.	067493	Red Reflector (2 Places) - Not used on this model
2.	067926	Amber Reflector - Not used on this model
3.	075741	WARNING - Install Transport Latch
4.	076894	CAUTION - Operator's Responsibility & Read Manual
5.	077682	CAUTION -General Safety
6.	087089	GEHL with Stripe
7.	088314	GEHL with Stripe (2 Places) - Not used on this model
8.	088363	216 -216 Model Only
	088364	217 -217 Model Only
	088365	219 -219 Model Only

NOTICE

Order paint for refinishing machines from this list:

901225	One Gallon Blaze Paint
901226	One Gallon Maize Paint
610239	6 (12oz) Cans Blaze Spray Paint
610240	6 (12oz) Cans Maize Spray Paint

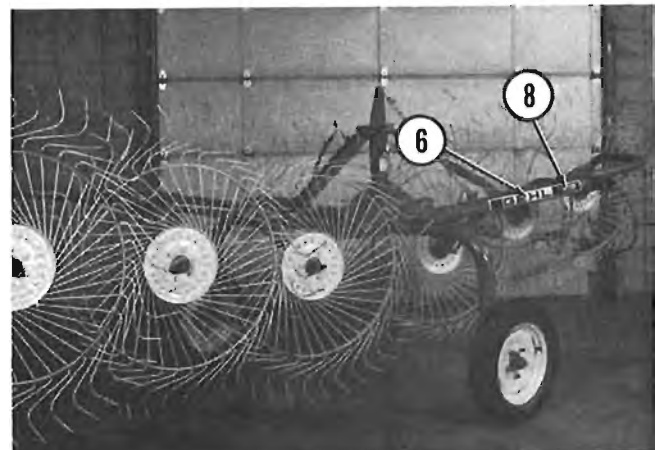
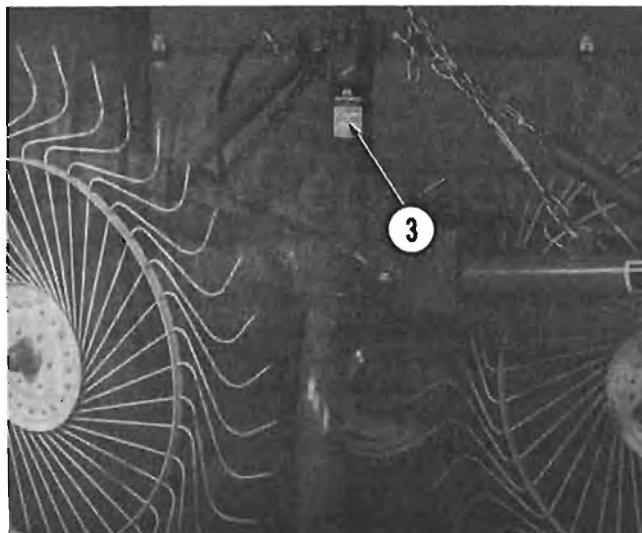
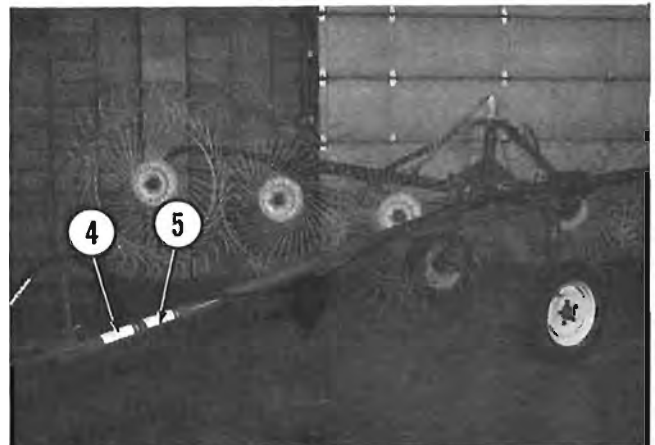

CHAPTER 10

SERVICE PARTS & NUMERICAL INDEX

When ordering service parts, specify the correct part number, full description, quantity required, the unit model number and serial number.

The Rake Model and Serial Number is stamped on a plate located on the Main Frame.

"Right" and "Left" are determined from a position standing behind the Rake and facing the direction of travel.

GEHL Company reserves the right to make changes or improvements in the design or construction of any part of the unit without incurring the obligation to install such changes on any unit previously delivered.

Common attaching hardware, such as Cotter Pins, Set Screws, Woodruff Keys, Screws, Nuts, etc., are included in the parts lists, indented below the part it is (they are) associated with:

DRAWBAR & WIDTH ADJUSTMENT

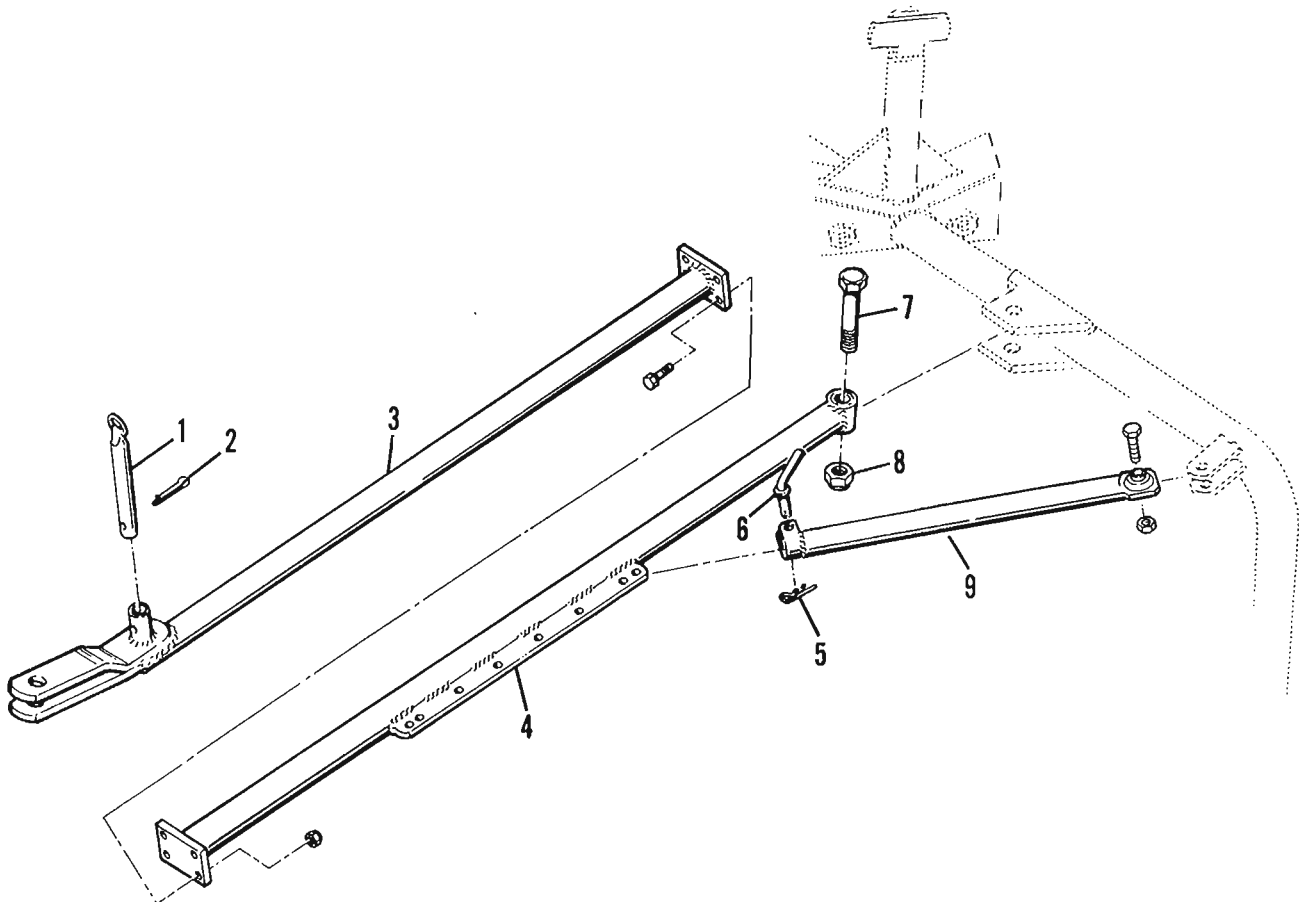

REF NO	PART NUMBER	PART DESCRIPTION...ETC..	QTY REQ	REF NO	PART NUMBER	PART DESCRIPTION...ETC..	QTY REQ
01	612761	STAND, HYDRAULIC HOSE....	1	05	076099	PIN, HAIRPIN COTTER 4MM..	1
02	604629	PIN, HAIRPIN COTTER 5MM..	1	06	612760	PIN, LOCK 16MM.....	1
03	613270	BAR/FRONT DRAW (RH).....	1	07	656136	CS 8.8/M27X140.....	1
	656017	CS 8.8/M12X35.....	4	08	613008	M27 NILN.....	1
	071247	M12 LN.....	4	09	613019	ROD, WIDTH ADJUSTMENT....	1
04	613269	BAR/REAR DRAW (RH).....	1		656042	CS 8.8/M20 X 90.....	1
					071250	M20 LN.....	1

MAIN FRAME, WHEELS & LIFT SYSTEM

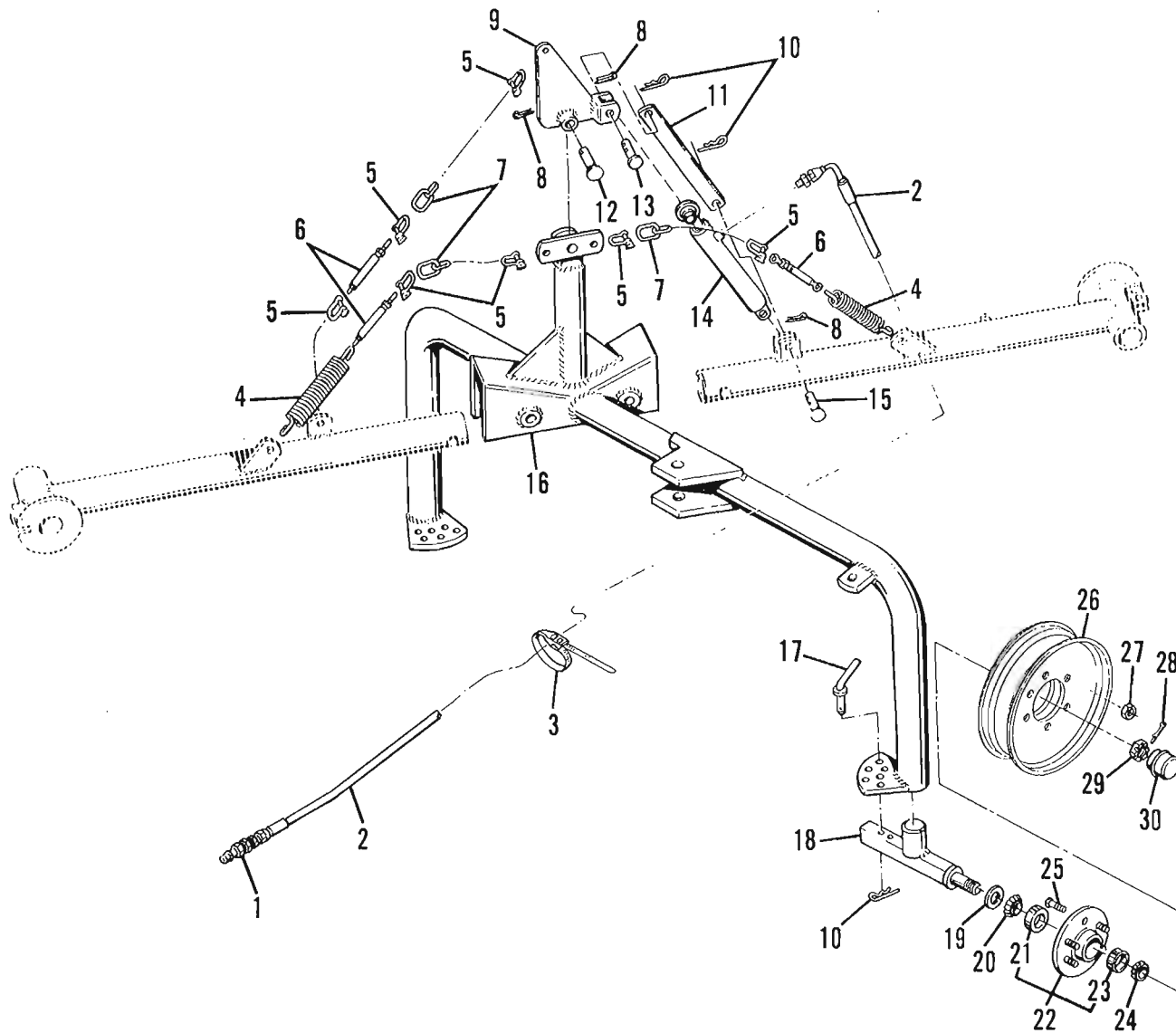

REF NO	PART NUMBER	PART DESCRIPTION...ETC..	QTY REQ	REF NO	PART NUMBER	PART DESCRIPTION...ETC..	QTY REQ
01	056080	COUPLER, HYD. DISCONNECT.	1	17	612760	PIN, LOCK.....	2
02	613017	HOSE, HYDRAULIC.....	1	18	613273	SPINDLE.....	2
03	613022	TIE, NYLON.....	10	19	613271	WASHER/SPINDLE.....	2
04	613009	SPRING, LIFT.....	2	20	612995	CONE, INNER BEARING.....	2
05	613001	SHACKLE/(5/16 DIA.).....	7	21	613275	CUP, INNER BEARING.....	2
06	613007	TURNBUCKLE, CHAIN.....	3	22	612994	HUB, WHEEL.....	2
	656050	M12 NUT.....	3	23	613276	CUP, OUTER BEARING.....	2
07	613002	CHAIN, LIFT.....	3	24	612996	CONE, OUTER BEARING.....	2
08	656071	PIN, COTTER (M4 X 25MM)...	3	25	613067	BOLT, HUB 16X45.....	10
09	612999	PLATE, LIFT.....	1	26	612992	RIM (FOR 5:00 X 15.....	2
10	076099	PIN, HAIRPIN COTTER 5/32.	4			TUBELESS TIRE)	
11	613003	BAR, TRANSPORT.....	1	27	613068	NUT, CONICAL LUG 16MM....	10
12	613000	PIN, LIFT PLATE PIVOT....	1	28	656075	PIN/SPLIT COTTER M6X40...	2
13	612998	PIN, HYD. CYLINDER ROD...	1	29	613272	NUT/SPINDLE.....	2
14	613004a	CYLINDER, HYDRAULIC.....	1	30	612997	CAP, HUB.....	2
15	613016	PIN, HYD CYLINDER ANCHOR.	1				
16	613006	MAIN FRAME, (RH).....	1				

a) FOR SEAL KIT, ORDER 613005.

FRONT & REAR FRAME, WHEEL ARMS & HUBS

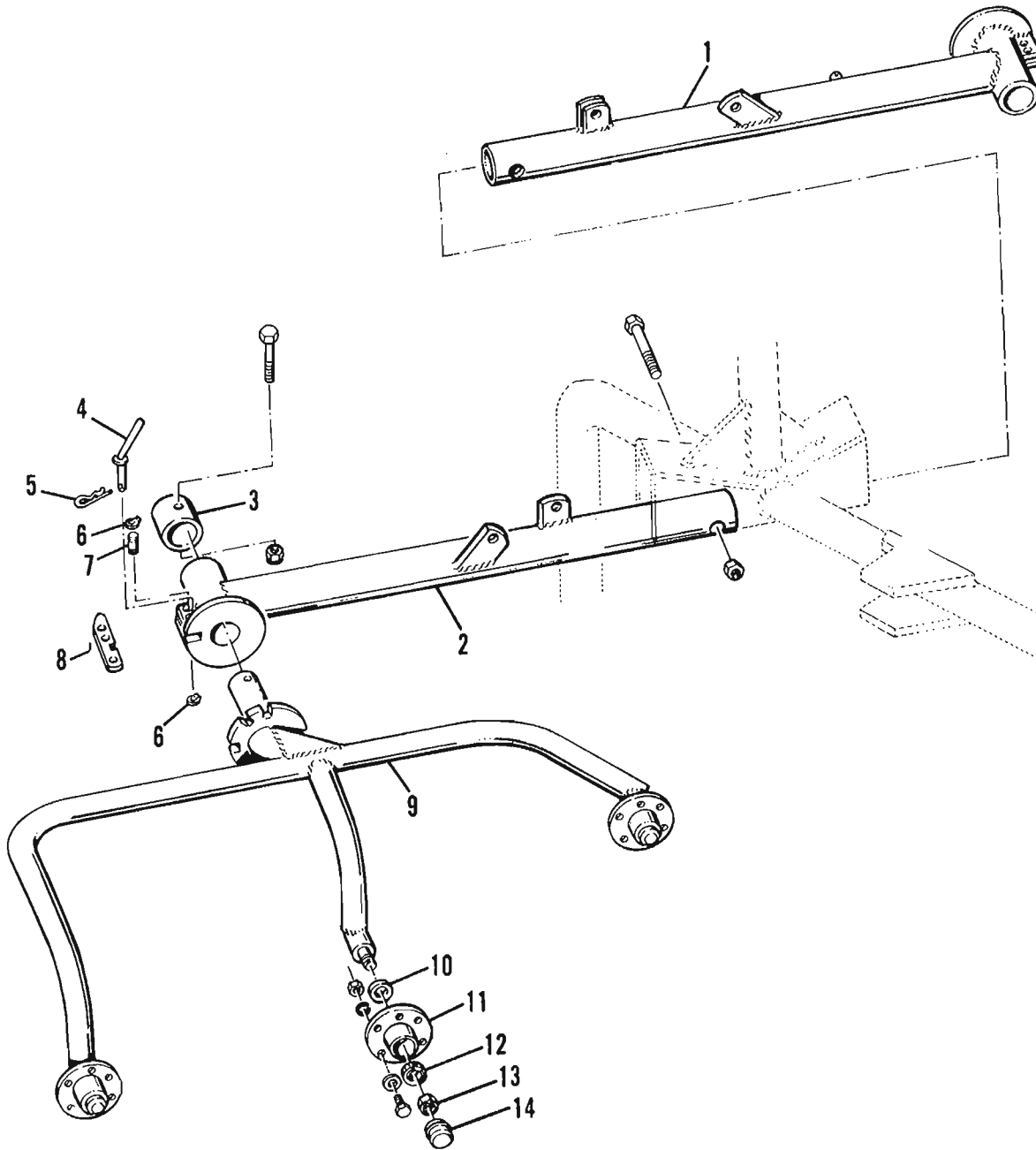

REF NO	PART NUMBER	PART DESCRIPTION...ETC..	QTY REQ	REF NO	PART NUMBER	PART DESCRIPTION...ETC..	QTY REQ
01	613012	FRAME, REAR (RH).....	1	07	612775	PIN, ARM LOCK.....	2
	656135	CS 8.8/M24X160.....	1	08	612774	LOCK, ARM.....	2
	613011	M24 LN.....	1	09	613013	ARM, WHEEL (RH).....	2
02	613010	FRAME, FRONT (RH).....	1	10	062367	BEARING, BALL.....	6
	656135	CS 8.8/M24X160.....	1	11	612787	HUB.....	6
	613011	M24 LN.....	1		656007	CS 8.8/M10X25.....	36
03	613014	RING, RAKE ARM.....	2		656049	M10 NUT.....	36
	656024	CS 8.8/M12X120.....	2		612103	M10 WASHER.....	36
	071247	M12 LN.....	2	12	520074	BEARING, BALL (6204).....	6
04	612772	PIN, LOCK.....	2	13	656134	LN M18X1.5.....	6
05	612773	PIN, HAIRPIN COTTER 2.5MM	2	14	612788	CAP, HUB.....	6
06	087596	RING, RETAINING 16MM DIA.	4				

FINGER WHEEL ASSEMBLY

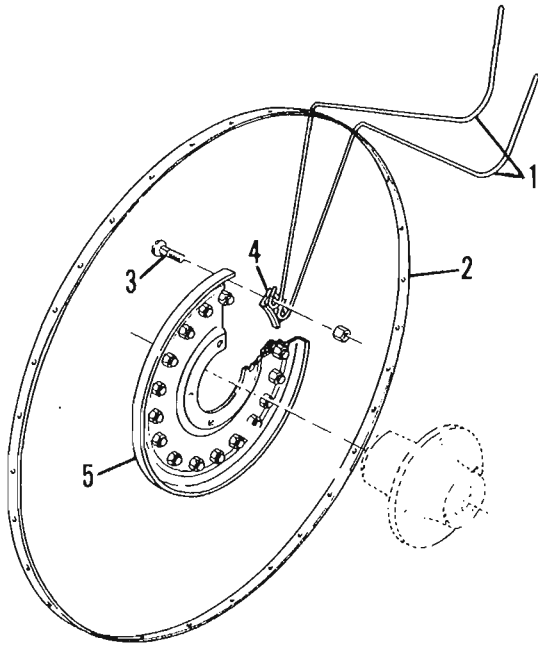

REF NO	PART NUMBER	PART DESCRIPTION...ETC..	QTY REQ
	612780	FINGER WHEEL ASSM. (RH)..	AR
		CONSISTS OF:	
01	612686	TINE.....	40
02	612781	RIM.....	1
03	612785	BOLT, TOOTH.....	20
	656049	NUT, M10/1.25.....	20
04	612784	CLIP.....	10
05	612782	PLATE, TINE.....	1

NUMERICAL INDEX

PART NO.	PAGE NO.	REF. NO.	PART NO.	PAGE NO.	REF. NO.	PART NO.	PAGE NO.	REF. NO.	PART NO.	PAGE NO.	REF. NO.
056080	21	01	612781	23	02	613001	21	05	613022	21	03
062367	22	10	612782	23	05	613002	21	07	613067	21	25
076099	20	05	612783	23	01	613003	21	11	613068	21	27
076099	21	10	612784	23	04	613004	21	14	613269	20	04
087596	22	06	612785	23	03	613006	21	16	613270	20	03
520074	22	12	612787	22	11	613007	21	06	613271	21	19
604629	20	02	612788	22	14	613008	20	08	613272	21	29
612760	20	06	612992	21	26	613009	21	04	613273	21	18
612760	21	17	612994	21	22	613010	22	02	613275	21	21
612761	20	01	612995	21	20	613012	22	01	613276	21	23
612772	22	04	612996	21	24	613013	22	09	656071	21	08
612773	22	05	612997	21	30	613014	22	03	656075	21	28
612774	22	08	612998	21	13	613016	21	15	656134	22	13
612775	22	07	612999	21	09	613017	21	02	656136	20	07
612780	23	00	613000	21	12	613019	20	09			

INDEX

	Page		Page
A			
Adjustments	14-15	Emergency Shutdown	10
Ground Pressure	14	General Information	10
Working Width	14-15	Mounting to Tractor	10
C			
Checklists	5-7	Transporting	10-11
Pre-delivery	5-7	Rake Operation	11-13
Delivery	5-7	S	
D			
Decal Locations	19	Safety	8-9
General Information	19	Service Parts & Numerical Index	20-24
New Decal Application	19	Drawbar & Width Adjustment	20
I			
Introduction	2	Main Frame, Wheels & Lift System	21
M			
Maintenance & Service	16	Front & Rear Frame, Wheel Arms & Hubs	22
Hardware	16	Finger Wheel Assembly	23
Lubrication	16	Set-up & Assembly	17-18
Tires & Wheels	16	Uncrating	17
MANDATORY SAFETY SHUTDOWN PRO-		Rake Assembly	17-18
CEDURE	8	Standard Hardware Torque	Inside Back Cover
O			
Operation	10-13	T	
		Table of Contents	1
		W	
		Warranty	Inside Front Cover

General Bolt Torque Data in Ft-Lb*

BOLT SIZE	GRADE					
	8.8		10.9		12.9	
Metric	DRY	LUB.	DRY	LUB.	DRY	LUB.
M6	8	6	11	8	13.5	10
M8	19	14	27	20	32.5	24
M10	37.5	28	53	39	64	47
M12	65	48	91.5	67.5	111.3	82
M14	103.5	76.5	145.5	108	176.5	131
M16	158.5	117.5	223.5	165.5	271	200.5

*Multiply by (1.355) for metric Nm



GEHL[®]
FARM EQUIPMENT

The logo features the word "GEHL" in a bold, blocky, sans-serif font, with a registered trademark symbol (®) to the right of the letter "L". This text is centered between two thick, solid horizontal bars. Below the second bar, the words "FARM EQUIPMENT" are written in a similar bold, blocky, sans-serif font.

GEHL COMPANY WEST BEND, WISCONSIN 53095 U.S.A.