

1840

Forage Box & Chassis Units

Form No.
909861
Revision C



PARTS MANUAL

GEHL® AGRICULTURE

Introduction

When ordering service parts, specify the correct part number, full description, quantity required, the unit model number and serial number.

The model number and serial number for this unit are on a decal located on the left side of the box frame just forward of the chain reduction drives. “Right” and “left” are determined from a position standing at the rear of the unit and looking toward the direction of travel.

GEHL Company reserves the right to make changes or improvements in the design or construction of any part of the unit without incurring the obligation to install such changes on any previously delivered units.

NOTE: *On original tire replacement, Company policy prohibits the sale of replacement tires for all GEHL machinery. Replacement wheel sets are available and tire size information is called out with the wheel sets to facilitate replacement tire selection. ALL REPLACEMENT TIRES MUST BE PURCHASED LOCALLY.*

Refer to the abbreviations table located on this page for the various fastener descriptions. Standard attaching hardware torque values are also provided on the inside back cover.

In the exploded view parts list, Reference Numbers may have additional information following the Reference Number. A number inside a hexagon will be the torque value required, in foot-pounds, on the associated Reference Number. Items shown in the parts list that do not have Reference Numbers are shown for reference purposes only and are NOT available for purchase.

Unless otherwise specified, all cap screws or bolts are Grade 5, zinc plated; hexagon nuts for Grade 5 screws or bolts are Grade B; hexagon nuts for other screws or bolts are Grade A.

NOTE: *The following abbreviations may be used herein:*

A/R	- As Required
ASSD	- Assembled
ASSY	- Assembly
CB	- Carriage Bolt
CCW	- Counterclockwise
CP	- Cotter Pin
CS	- Cap Screw (Hexagon Head)
CTR	- Center
CW	- Clockwise
DEG	- Degree
DIA	- Diameter
FCS	- Flanged Cap Screw
FHMS	- Flat Head Machine Screw
FL	- Flanged
FLN	- Flanged Lock Nut (Hexagon)
FLS	- Flanged Lock Screw (Hexagon)
FW	- Flat Washer
GA	- Gauge
GR	- Grade
HD	- Hard or Head
HN	- Hex Nut
INCL	- Includes
JT	- Joint
LG	- Large
LN	- Lock Nut
LW	- Lock Washer
LT	- Left
M	- Metric
MM/mm	- Millimeter
NF	- National Fine
PB	- Plow Bolt
PTO	- Power Take Off
RHMS	- Round Head Machine Screw
RPM	- Revolutions Per Minute
RT	- Right
SERR	- Serrated
SHCS	- Socket Head Cap Screw
SHSS	- Socket Head Set Screw
SN	- Serial Number or Slotted Nut
SQ	- Square
T	- Tooth or Teeth
TFS	- Thread Forming Screw
THMS	- Truss Head Machine Screw
THRD	- Thread
WLDMT	- Weldment
#	- Number
	- Torque required in foot-pounds

TABLE OF CONTENTS

Introduction	Inside Front Cover
Decal Locations	2-5
Door, Apron Drive & Idler Assembly	6-9
Box Components	10-13
Chassis Components	14-15
Lights & Tie Down Kit	16
Auger Unit	17
Hydraulics	18-19
Options (Deflector)	20
Alphabetical Index	21
Numerical Index	22-23
Notes	24
Standard Hardware Torque Specifications	Inside Back Cover

DECAL LOCATIONS

GENERAL INFORMATION

Decal location information is provided to assist in the proper selection and application of new decals, in the event the original decals become damaged or the machine is repainted. Refer to the listing for the illustration reference number, part number, description and quantity of each decal provided in the kit. Refer to the appropriate illustrations for replacement locations.

NOTE: Refer to the *SAFETY* chapter of the *Operator's Manual* for the specific information provided on the various safety decals furnished in the decal kits.

To ensure proper selection of the correct replacement decals, compare the various location photographs to your machine before starting to refinish the unit. Then circle each pictured decal (applicable to your machine) while checking off its part number in the listing. After you have verified all the decals needed for replacement, place any unneeded decals aside for disposal.

NEW DECAL APPLICATION

Surfaces **MUST** be free from dirt, dust, grease and other foreign material before applying the new decal. To apply, remove the smaller portion of the decal backing paper and apply this part of the exposed adhesive backing to the clean surface while maintaining proper position and alignment. Peel the other portion of the backing paper off slowly while applying hand pressure to smooth out decal surface.



CAUTION

ALWAYS observe safety precautions on decals. If decals become damaged, or if the unit is repainted, replace the decals. If repainting, **BE SURE** that **ALL** decals from the kits that apply to your machine are affixed to your unit.

PAINT NOTICE

Use this list to order paint for refinishing:
906315 One Gal. AG Red
902872 One Qt. Light Grey
906316 6 (12 oz. Spray Cans) AG Red
902874 6 (12 oz. Spray Cans) Light Grey

The decal set number for the 1840 Forage Box is 170508. The set includes the following:

Ref. No.	Part No.	Description & Quantity
1	122616	Decal - GEHL
2	170319	1840 Label (Both Sides)
3	170356	Decal - GEHL (Both Sides)
4	170355	Decal - FORAGE MAX (Both Sides)
5	093444	WARNING - Moving Parts (6 Places-Both Sides)
6	145217	Amber Reflector (6 Places-Both Sides)
7	163957	WARNING - Do Not Remove Shields (2 Places)
8	093367	WARNING - Read Operator's Manual
9	170532	WARNING - Do Not Go Near Leaks
10	093373	WARNING - Before Inspecting
11	119661	Decal - GEHL
12	145216	Red Reflector (2 Places)
13	170520	WARNING - Do Not Operate
14	093366	Decal - Manual Location

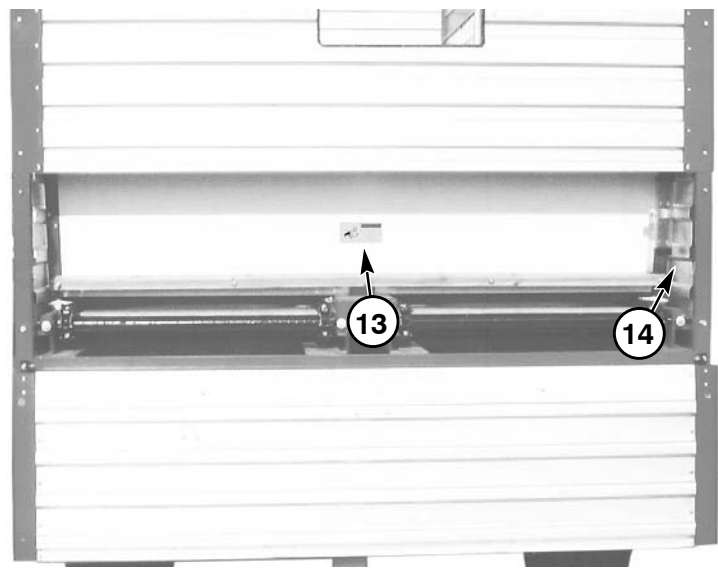
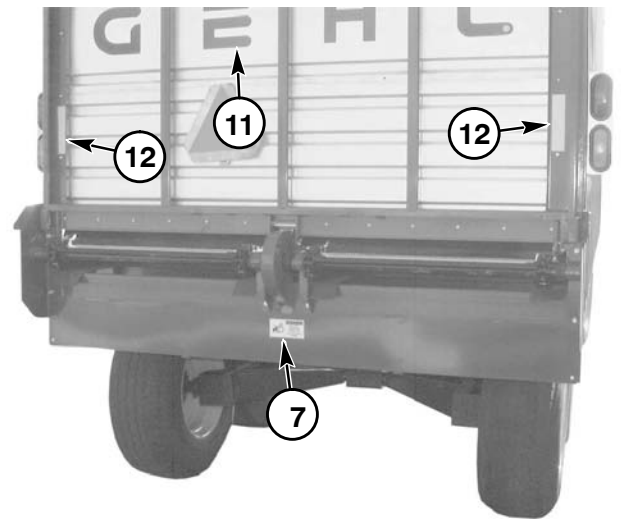
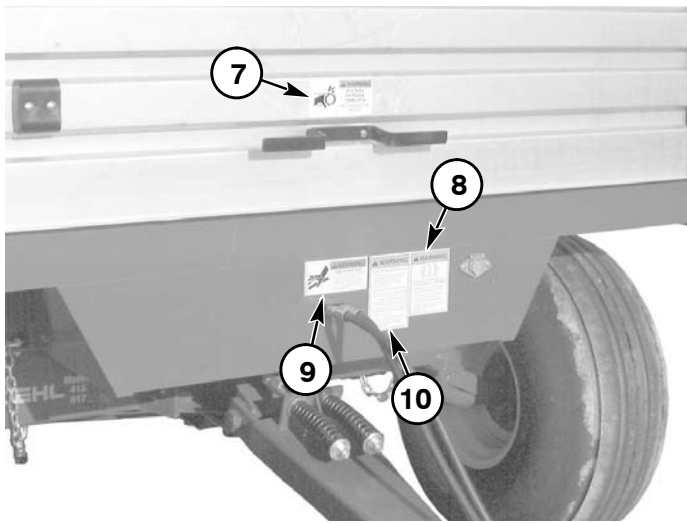
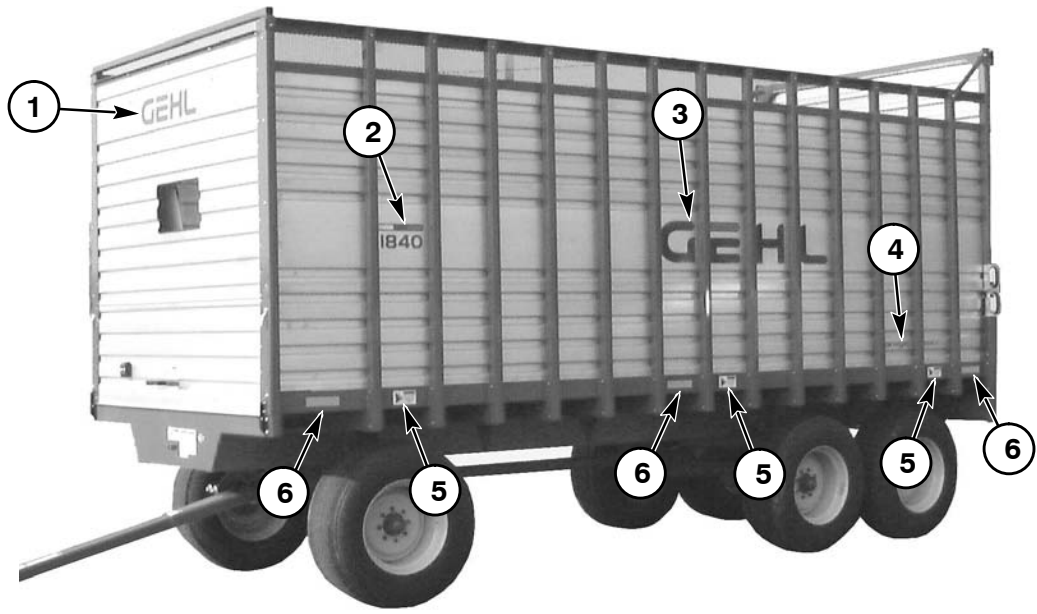

Refer to the listing for the illustration reference number, part number, description and quantity of each decal provided in the kit. Refer to the appropriate illustrations for replacement locations.

Complete decal kits for the chassis type Running Gear models are available as follows:

- 416C - 174709
- 420C - 170518
- 422C - 174710

The kits include the following:

Ref. Part

No.	No.	Description & Quantity
8	093367*	WARNING - Read Operator's Manual
10	093373*	WARNING - Before Inspecting
15	093443	WARNING - Towing
16	170494	Decal - GEHL
17	174707	32000 lbs. Capacity (416C)
	- 170504	40000 lbs. Capacity (420C)
	- 174708	44000 lbs. Capacity (422C)
18	158180	WARNING - Crushing Hazard (2 Places)

* Decals 093367 & 093373 replace the originally applied decal labeled 1495B.

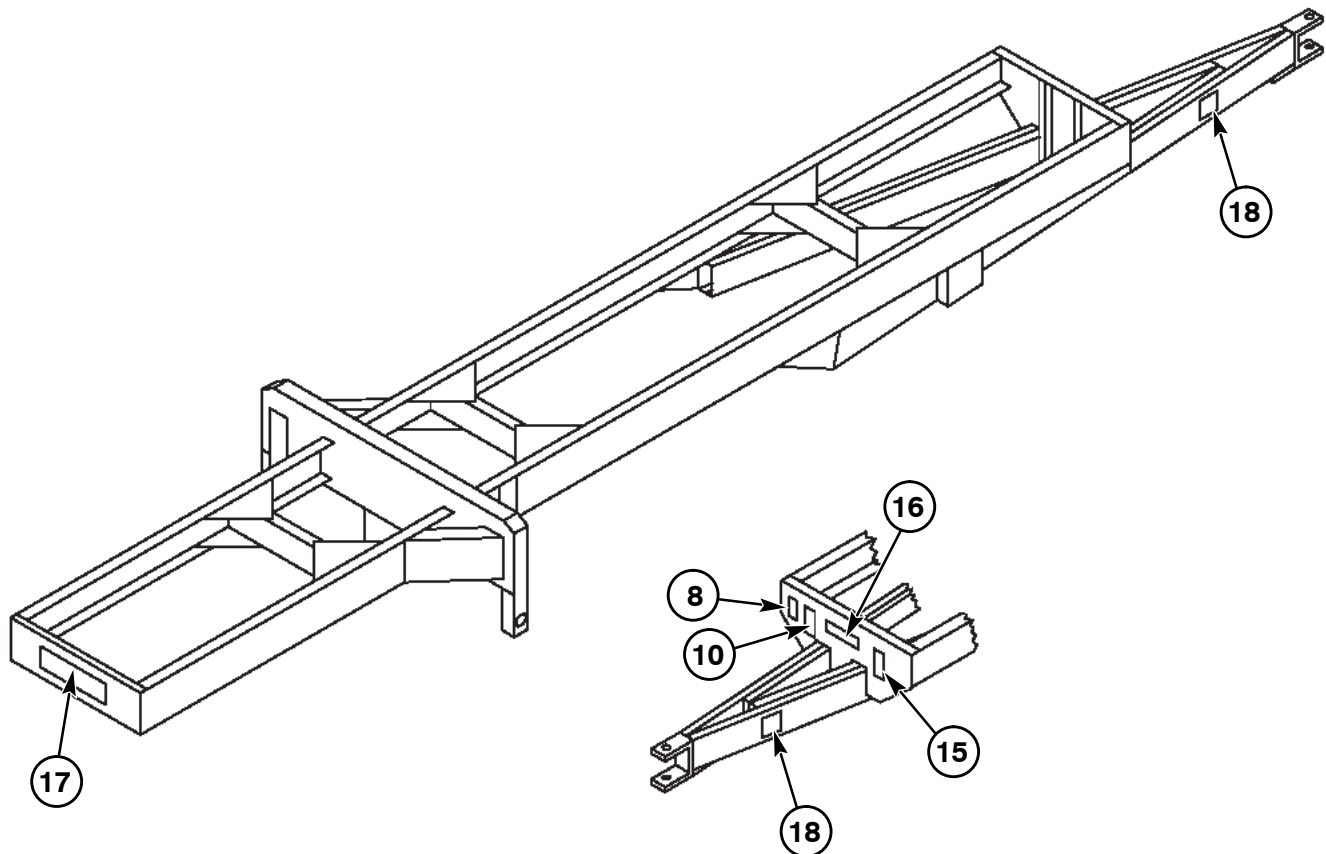

INTENTIONALLY BLANK

1840 - DOOR, APRON DRIVE & IDLER ASSEMBLY

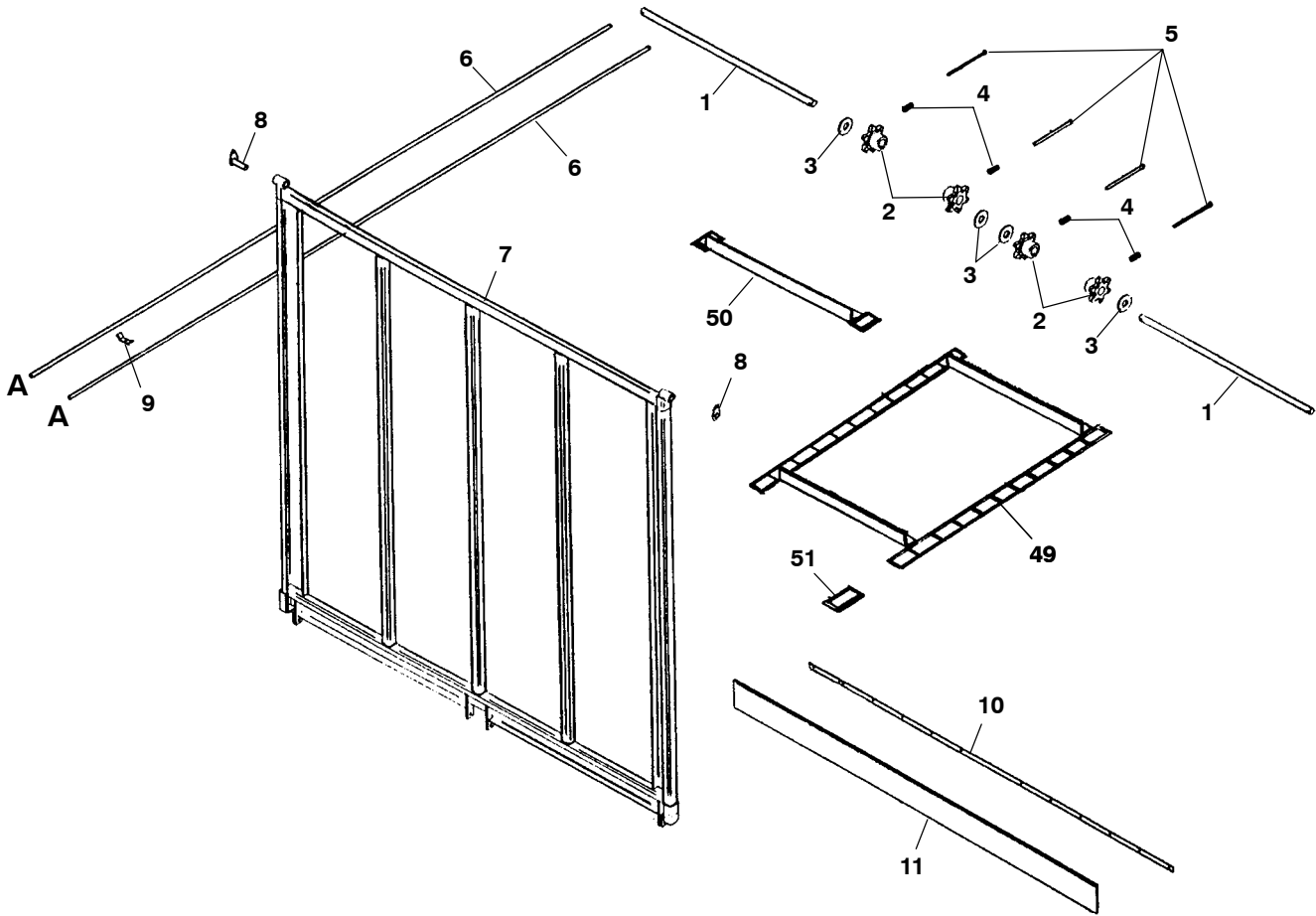

1840 - DOOR, APRON DRIVE & IDLER ASSEMBLY

Ref. No.	Part No.	Description	(ALUMINIZED)		(POLY BONDED)
			20'	22'	24'
1	166811	REAR IDLER SHAFT	2	2	2
2	166885	REAR IDLER SPROCKET	4	4	4
3	166886	IDLER SHAFT SPACER	4	4	4
4	166844	SPRING-RED	4	4	4
5	166084	CS 1/2X9-1/2 C5ZY	4	4	4
6	166358	HYDRAULIC PIPE	-	2	-
	166235	HYDRAULIC PIPE	-	-	2
	166370	HYDRAULIC PIPE	2	-	-
7	166255	BACK DOOR FRAME WORK	1	1	1
8	166265	DOOR HINGE PIN	2	2	2
9	166073	HOSE HOLDER	4	4	4
10	166352	SEAL STRAP	1	1	1
11	166351	RUBBER SEAL	1	1	1
49	166359	20' COMPLETE T-ROD APRON	2	-	-
*	166355	22' COMPLETE 667XH APRON	-	2	-
*		(848 TOTAL LINKS PER APRON, 26 TOTAL SLATS PER APRON)			
	166257	24' COMPLETE 667XH APRON	-	-	2
		(924 TOTAL LINKS PER APRON, 28 TOTAL SLATS PER APRON)			
50	166805	T-ROD SLAT W/ATTACH LINKS	48	-	-
*	166193	667XH PINTLE SLAT W/ATTACH LINKS	-	26	28
51	166806	T-ROD STANDARD LINK	768	-	-
*	166191	667XH PINTLE CONNECTOR	-	4	4
*	166190	667XH PINTLE ATT. LINK LH OR RH	-	52	56

- Not available on this model

* Not Shown

1840 - DOOR, APRON DRIVE & IDLER ASSEMBLY

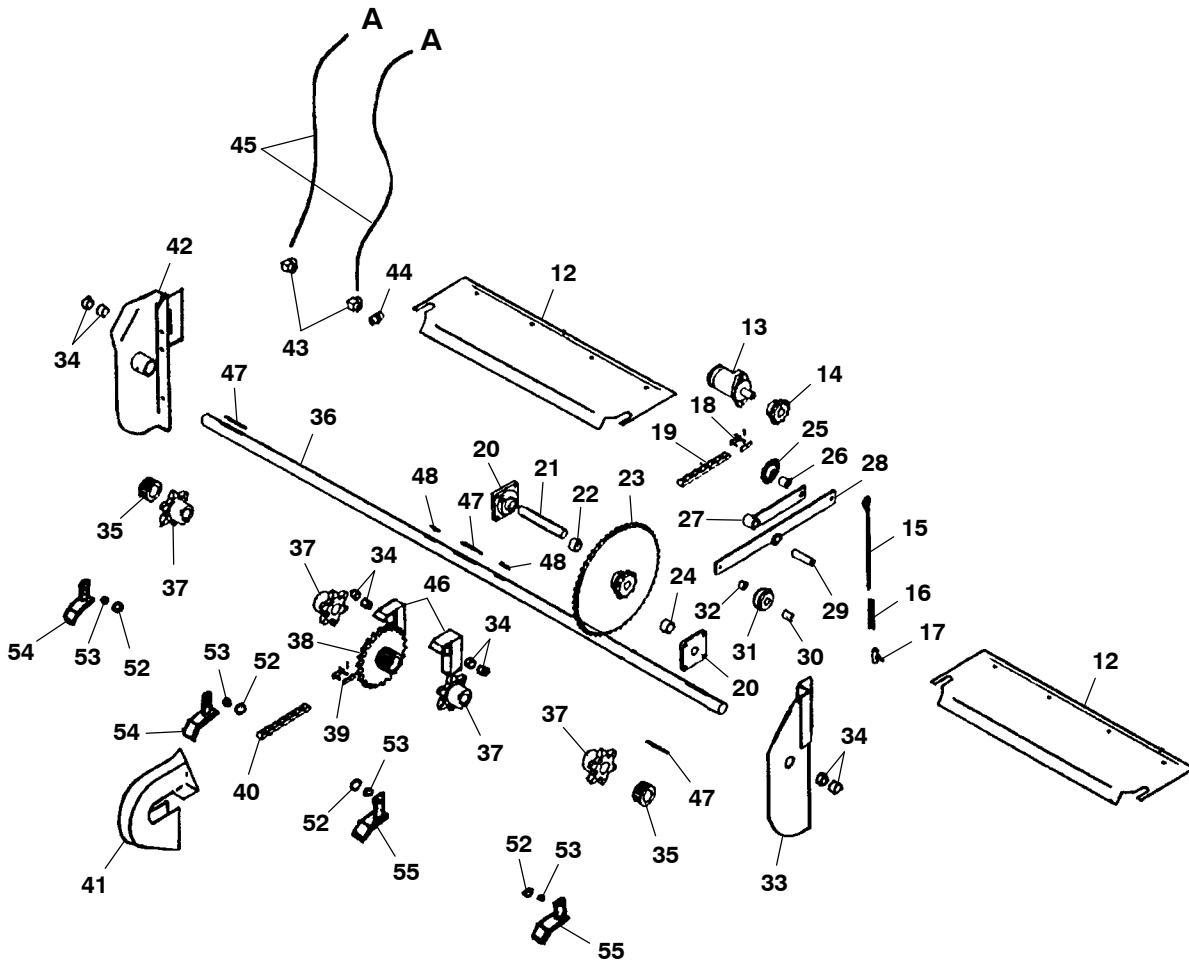

1840 - DOOR, APRON DRIVE & IDLER ASSEMBLY

Ref. No.	Part No.	Description	(ALUMINIZED)		(POLY BONDED)
			20'	22'	24'
12	166390	DRIVE SHAFT PANEL	2	2	2
13	166063	HYDRAULIC MOTOR	1	1	1
14	166900	MOTOR SPROCKET	-	1	1
	166908	MOTOR SPROCKET	1	-	-
15	166285	TIGHTENER ROD	1	1	1
16	166070	SPRING 3/4	1	1	1
17	166202	TIGHTENER ROD HOLDER	1	1	1
18	500195	#80 CONNECTOR LINK	-	1	1
	500160	#60 CONNECTOR LINK	1	-	-
19	166064	CHAIN #80 X 68 LINKS	-	1	1
	500087	CHAIN #60 X 92 LINKS	1	-	-
20	166079	BEARING W/HOLDER	2	2	2
21	167738	SHAFT W/SNAP RINGS	1	1	1
22	166403	SHORT IDLER SPACER	1	1	1
23	166092	SHORT IDLER SPROCKET	-	1	1
	166091	SHORT IDLER SPROCKET	1	-	-
24	166909	SPACER	1	1	1
25	166061	SPROCKET	-	1	1
	H7812	SPROCKET	1	-	-
26	166315	PRIMARY DRIVE SPACER	1	1	1
27	166236	SHORT TIGHTENER	1	1	1
28	166237	LONG TIGHTENER	1	1	1
29	166247	TIGHTENER AXLE PIVOT	1	1	1
30	166251	POLY CHAIN TIGHTENER AXLE	1	1	1
31	166252	CHAIN TIGHTENER ROLLER	1	1	1
32	166258	SPACER	1	1	1
33	166253	RH DRIVE SHAFT MOUNT	1	1	1
34	166884	BUSHING	8	8	8
35	166103	LATCH SPROCKET	4	4	4
36	166356	DRIVE SHAFT	1	1	1
37	166761	APRON DRIVE SHAFT SPROCKET	4	4	4
38	166090	CENTER DRIVE SHAFT SPROCKET	-	1	1
	166102	CENTER DRIVE SHAFT SPROCKET	1	-	-
39	606065	#100 CONNECTOR LINK	-	1	1
	055365	#80H CONNECTOR LINK	1	-	-
40	166167	#100 CHAIN 47 PITCHES	-	1	1
	166169	#80H CHAIN 56 PITCHES	1	-	-
41	166254	CENTER DRIVE SHIELD	1	1	1
42	166256	LH DRIVE SHAFT MOUNT	1	1	1
43	660086	STR RED FP 3/4 X 1/2	2	2	2
44	166901	CHECK VALVE	1	1	1
45	166067	HOSE 1/2 X 41	2	2	2
46	166362	CENTER BEARING BRACKET	1	1	1
47	166100	KEY 3/8 SQ. X 4-3/8	3	3	3
48	056230	KEY 3/8 SQUARE X 2 LONG	2	2	2
52	166217	LATCH WASHER	4	4	4
53	166380	LATCH PIVOT	4	4	4
54	166378	LATCH BRACKET - LH	2	2	2
55	166377	LATCH BRACKET - R.H.	2	2	2
*	166354	BACK DOOR ALUMINIZED PANELS	1	1	-
*	166287	BACK DOOR POLY	-	-	1

- Not available on this model

* Not Shown

1840 - BOX COMPONENTS

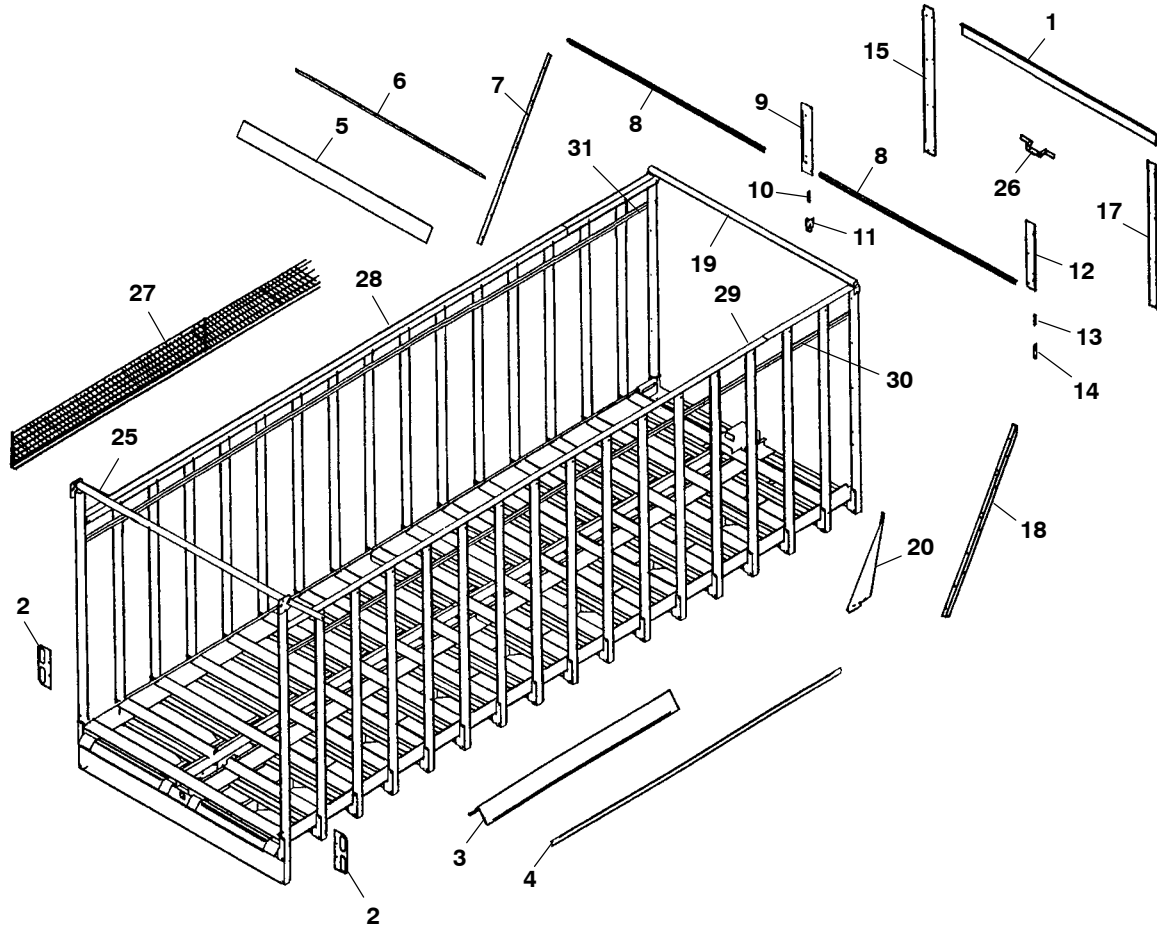

Ref. No.	Part No.	Description	(ALUMINIZED)		(POLY BONDED)
			20'	22'	24'
1	166269	TOP FRONT DOOR PANEL	-	-	1
	166314	TOP FRONT DOOR PANEL	1	1	-
2	166329	LIGHT BRACKETS	2	2	2
3	166346	CENTER FLOOR RIDGE	3	3	3
4	166262	FILLER CORNER	6	6	6
5	166351	RUBBER SEAL	1	1	1
6	166352	SEAL STRAP	1	1	1
7	166263	ANGLE BRACKET LH	1	1	1
8	166264	PANEL ANGLE	-	-	1
9	166266	FRONT DOOR BOTTOM LEFT	-	-	1
	166282	FRONT DOOR BOTTOM LEFT	1	1	-
10	166657	DOOR HINGE LH	1	1	1
11	166656	LH STAKE HINGE	1	1	1
12	166267	FRONT DOOR BOTTOM RIGHT	-	-	1
	166283	FRONT DOOR BOTTOM RIGHT	1	1	-
13	166651	DOOR HINGE RH	1	1	1
14	166652	RH STAKE HINGE	1	1	1
15	166280	TOP FRONT PANEL LH	-	-	1
	166268	TOP FRONT PANEL LH	1	1	-

1840 - BOX COMPONENTS

Ref. No.	Part No.	Description	(ALUMINIZED)		(POLY BONDED)
			20'	22'	24'
17	166281	TOP FRONT PANEL RH	-	-	1
	166270	TOP FRONT PANEL RH	1	1	-
18	166271	ANGLE BRACKET RH	1	1	1
19	166272	CROSS FRONT BRACE	1	1	1
20	166273	INSIDE DEFLECTOR BRACE	1	1	1
25	166279	TOP REAR BRACE	1	1	1
26	166106	HOSE HOLDER	1	1	1
27	166284	LH SCREEN	-	1	-
	166310	LH SCREEN	-	-	1
	166312	LH SCREEN	1	-	-
*	166238	RH SCREEN	-	1	-
*	166239	RH SCREEN	-	-	1
*	166241	RH SCREEN	1	-	-
28	166291	22' LH TOP RAIL	-	1	-
	166293	24' LH TOP RAIL	-	-	1
	166289	20' LH TOP RAIL	1	-	-
29	166292	22' TOP RAIL	-	1	-
	166294	24' TOP RAIL	-	-	1
	166290	20' TOP RAIL	1	-	-
30	166242	RH TOP ANGLE	-	1	-
	166243	RH TOP ANGLE	-	-	1
	166245	RH TOP ANGLE	1	-	-
31	166246	LH TOP ANGLE	-	1	-
	166248	LH TOP ANGLE	-	-	1
	166250	LH TOP ANGLE	1	-	-

* Not Shown

1840 - BOX COMPONENTS

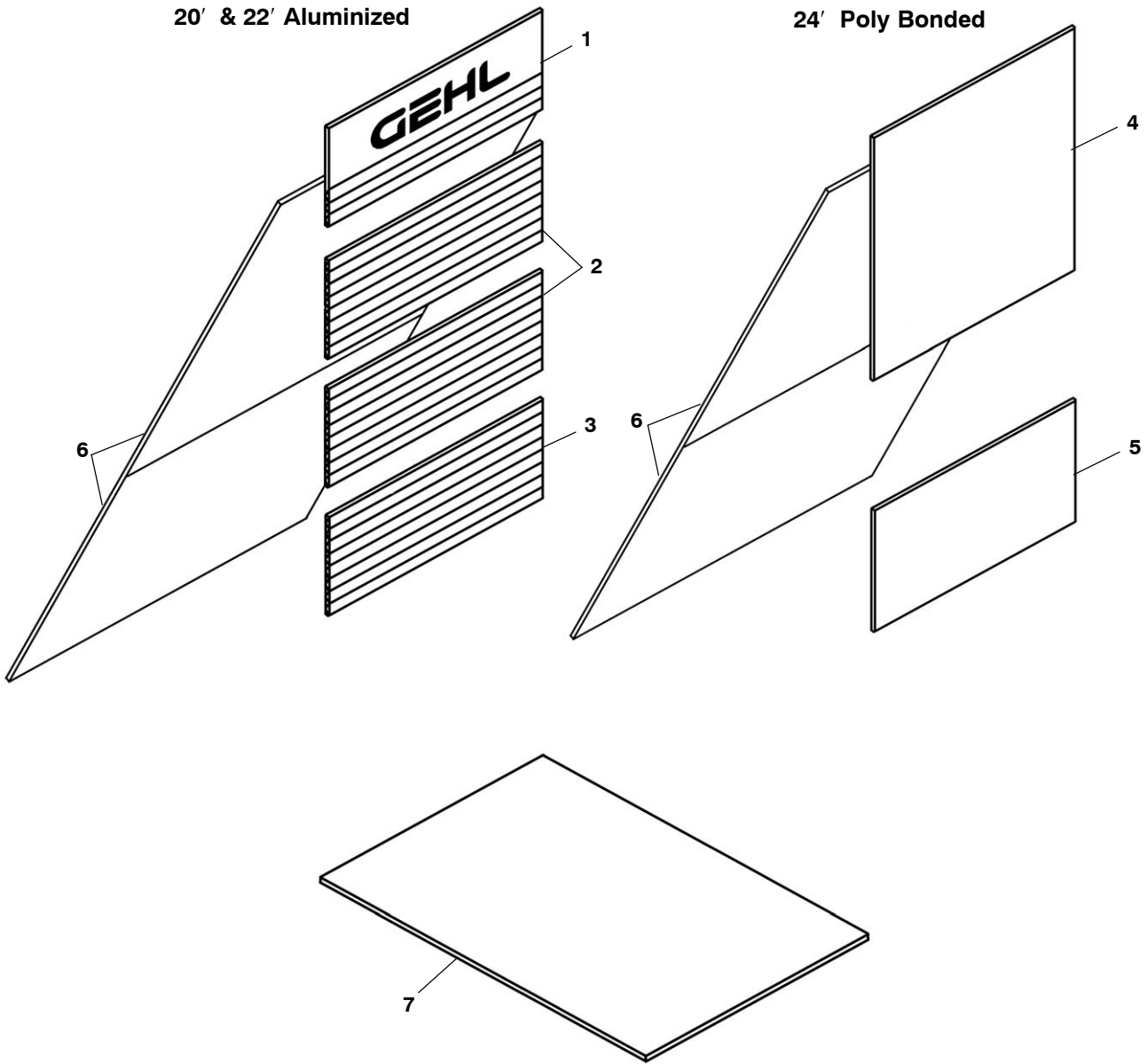

Ref. No.	Part No.	Description	(ALUMINIZED)		(POLY BONDED)
			20'	22'	24'
1	166348	ALUMINIZED FRONT PANEL TOP	1	1	-
2	166347	ALUMINIZED FRONT PANELS TOP	2	2	-
3	166349	ALUMINIZED FRONT PANEL	1	1	-
4	166299	POLY BONDED FRONT TOP PANEL	-	-	1
5	166300	POLY BONDED FRONT TAILGATE PANEL	-	-	1
6	166313	INSIDE SHELF POLY PANEL	2	2	2
7	166343	POLY BONDED FLOOR PANEL (22')	-	2	-
	166309	POLY BONDED FLOOR PANEL (24')	-	-	2
	166308	PLYWOOD FLOOR PANEL (20')	2	-	-

1840 - BOX COMPONENTS

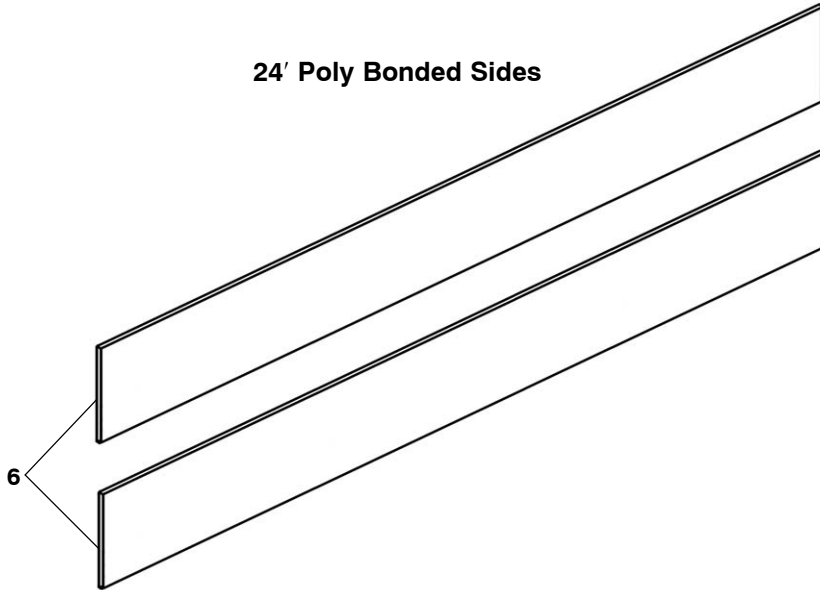
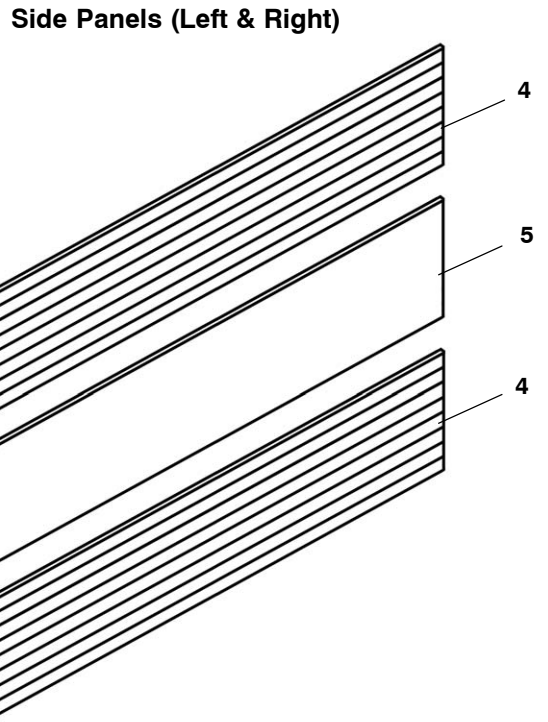
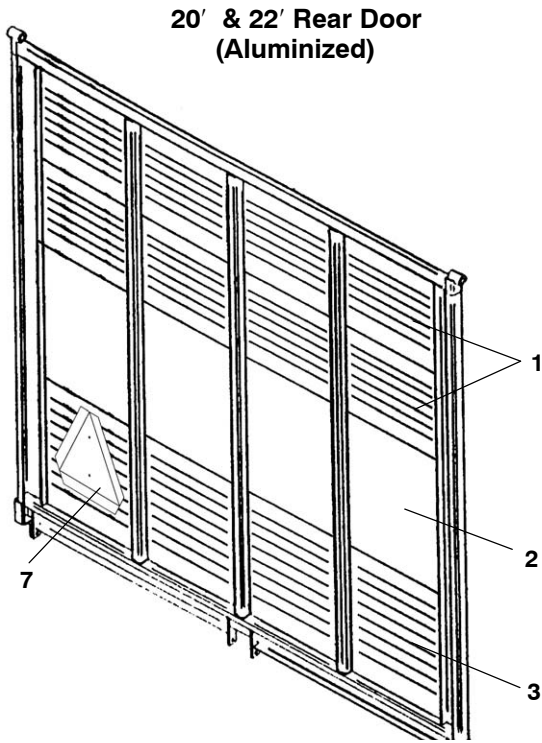

Ref. No.	Part No.	Description	(ALUMINIZED)		(POLY BONDED)
			20'	22'	24'
1	166354	REAR DOOR PANEL	2	2	-
2	166305	REAR PANEL CENTER	1	1	-
3	166306	REAR PANEL LOWER	1	1	-
4	166302	SIDE PANEL	4	-	-
	166304	SIDE PANEL	-	4	-
5	166712	SIDE CENTER PANEL	2	-	-
	166303	SIDE CENTER PANEL	-	2	-
6	166298	24' POLY BONDED SIDES	-	-	4
7	145235	SMV MARKER/MOUNTED	1	1	1

1840 - CHASSIS COMPONENTS

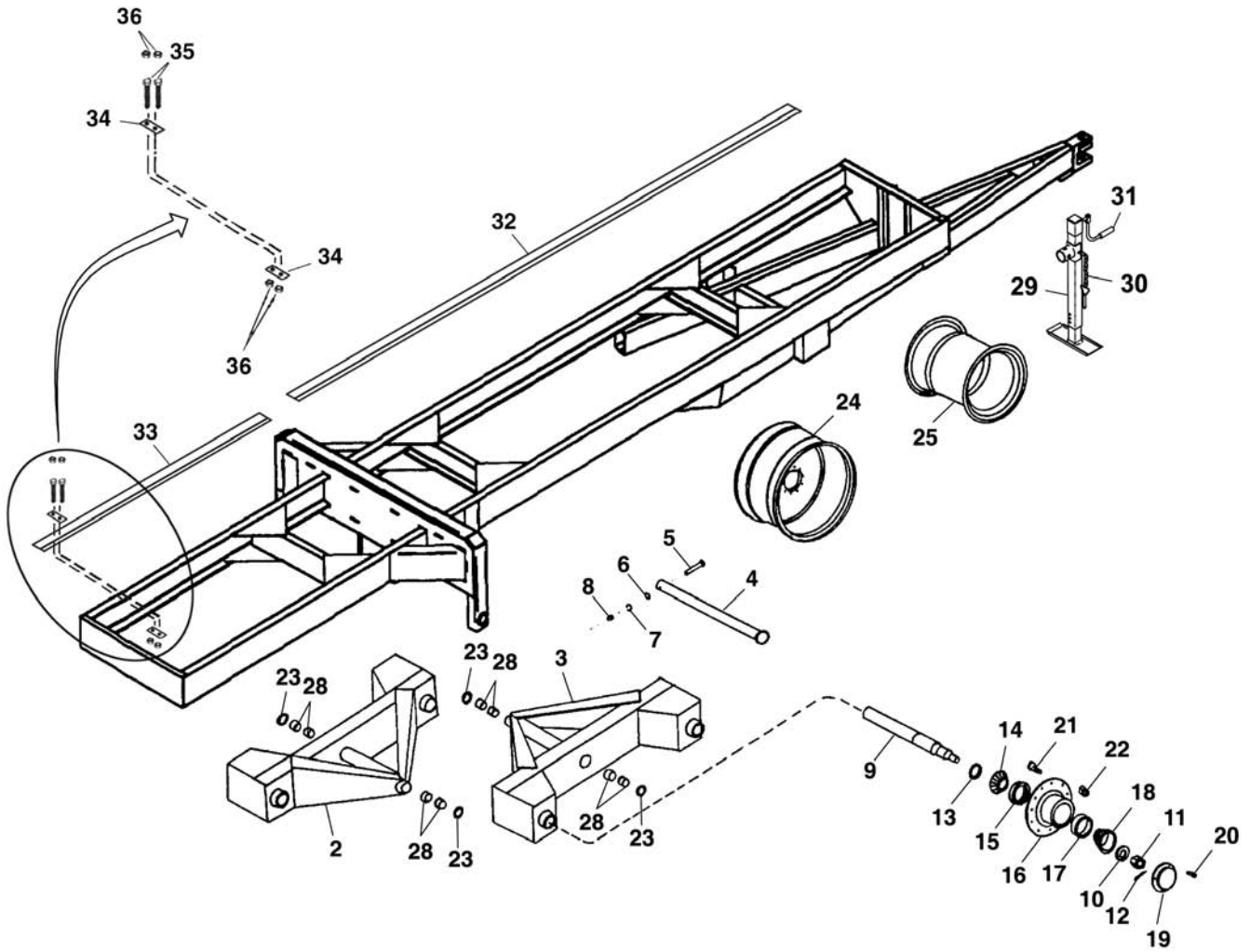

1840 - CHASSIS COMPONENTS

Ref. No.	Part No.	Description	416C	420C	422C
2	166212	TANDEM BEAM LT	1	1	1
3	166864	TANDEM BEAM RT	1	1	1
4	166213	TANDEM PIN	2	2	2
5	650867	BOLT 5/8 X 5 GR. 5	2	2	2
6	651150	FW 5/8	2	2	2
7	654032	LW 5/8	2	2	2
8	653021	HN 5/8	2	2	2
9	166858	SPINDLE (10 BOLT HUB)	-	4	4
	166857	SPINDLE (8 BOLT HUB)	4	-	-
10	166539	WASHER 3-1/2 X 1-5/16 X 1/4	-	4	4
	166207	WASHER	4	-	-
11	651381	HN SLTD 1-1/4 F2	-	4	4
	650933	HN SLTD 1 F2	-	-	-
12	651573	CP EPSC 7/32X2	-	4	4
	655020	CP EPSC 3/16X1-1/2	4	-	-
13	166085	SEAL	-	4	4
	166069	SEAL	4	-	-
14	112191	BEARING CONE	-	4	4
	083108	BEARING CONE	4	-	-
15	112190	BEARING CUP	-	4	4
	520013	BEARING CUP	4	-	-
16	166088	HUB (10 BOLT)	-	4	4
	116072	HUB (8 BOLT)	4	-	-
17	120433	BEARING CUP	-	4	4
	042162	BEARING CUP	4	-	-
18	120434	BEARING CONE	-	4	4
	042163	BEARING CONE	4	-	-
19	120617	HUB CAP	-	4	4
	003938	HUB CAP	-	4	4
20	650484	CS 5/16 X 1/2	16	16	16
21	120403	WHEEL BOLT 3/4X2-9/16	-	40	40
	083107	WHEEL BOLT 5/8X2-1/2	32	-	-
22	120538	HN 3/4	-	40	40
	079152	HN 5/8	32	-	-
23	166476	THRUST WASHER 1/16	4	4	4
24	141268	WHEEL 22.5 X 13.5 (10 BOLT)	-	4	4
25	141266	WHEEL 16.1 X 18 (10 BOLT)	-	4	-
	158061	WHEEL 22.5 X 13.5 (8 BOLT)	4	-	-
28	166214	TANDEM PIN BUSHING	8	8	8
29	167742	JACK/ASSY	1	1	1
30	167743	HANDLE/JACK	1	1	1
31	167744	PIN AND CHAIN/JACK	1	1	1
32	167745	SPACER/WOOD FRONT	1	1	1
33	167746	SPACER/WOOD REAR	1	1	1
34	167747	PLATE/TIE DOWN	16	16	16
35	167748	BOLT/TIE DOWN	16	16	16
36	126530	LN 3/4	32	32	32

1840 - LIGHTS & TIE DOWN KIT

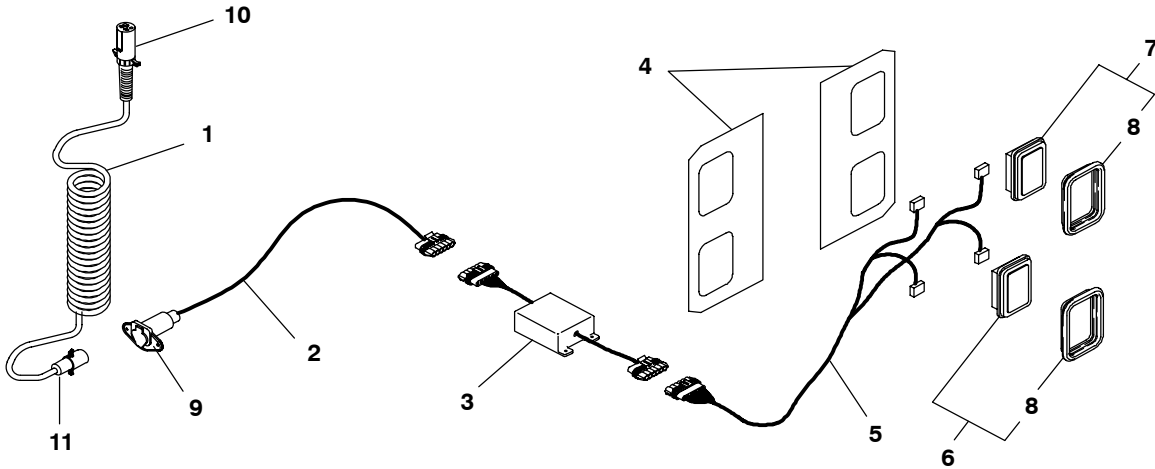

Ref. No.	Part No.	Description	Qty. Req.	Ref. No.	Part No.	Description	Qty. Req.
1	119514	RETRACTABLE CORD (ACCESSORY OPTION)	1	6	166199	RED LIGHT	2
2	166965 _a	FRONT HARNESS	1	7	166198	AMBER LIGHT	2
3	170670 _a	LIGHTING MODULE	1	8	166720	RUBBER LIGHT MOUNT	4
4	166329	LIGHT BRACKET	2	9	059060	4 WAY SOCKET	1
5	170673	Y CONNECT HARNESS	1	10	112917	PLUG/ 7-PIN W/CABLE	1
6	166199	RED LIGHT	2	11	059070	PLUG/4 WAY TRAILER	1

a) Not supplied on Truck Mounted units.

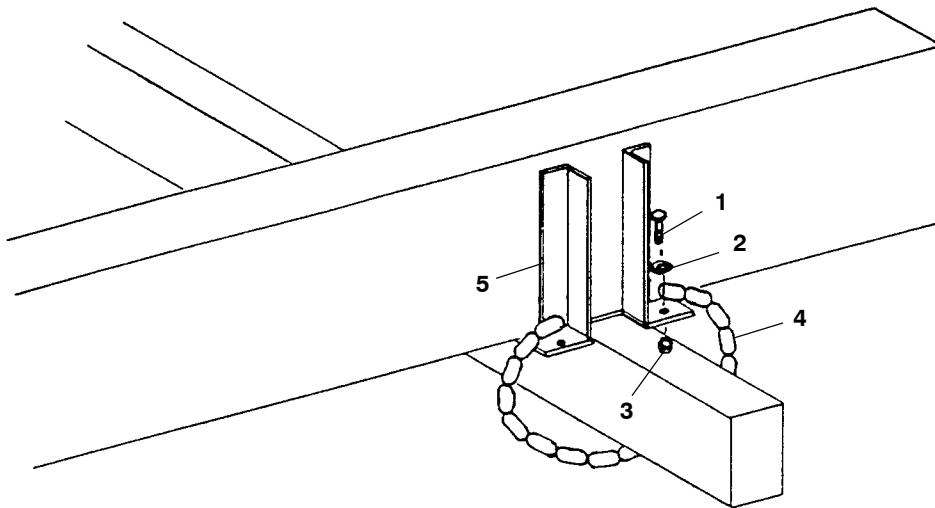

Ref. No.	Part No.	Description	Qty. Req.
1	650453	CS 1/2X1-1/2	8
2	651148	FW 1/2	8
3	071706	LN T 1/2	8
4	166726	1/4 TIE DOWN CHAIN	4
5	166727	TIE DOWN BRACKET	4

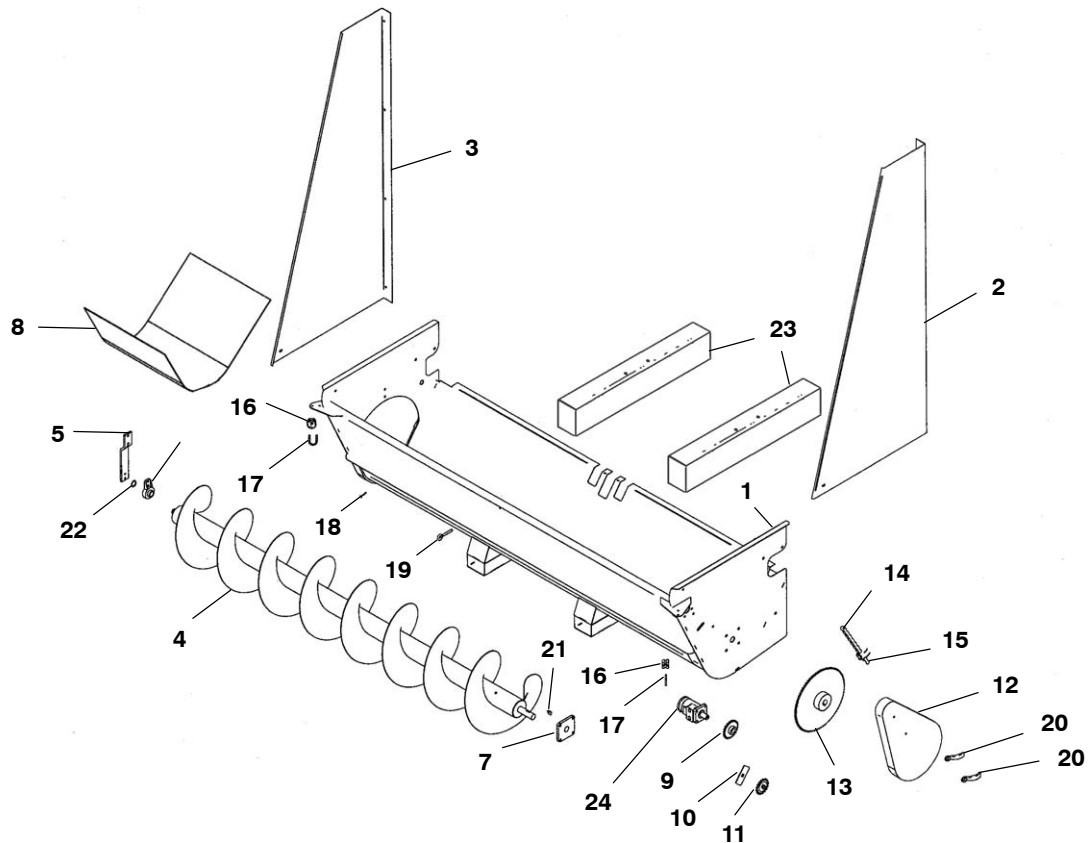

Ref. No.	Part No.	Description	Qty. Req.	Ref. No.	Part No.	Description	Qty. Req.
1	450069	AUGER HOUSING	1	14	167863	CHAIN/ROLLER #50 X 114	1
2	450072	SIDE PANEL RIGHT	1	15	500057	COUPLER/PLAIN	1
3	450073	SIDE PANEL LEFT	1	16	166225	CABLE GUIDE	2
4	166973	AUGER	1	17	450068	U-BOLT	2
5	166974	AUGER POST	1	18	166166	HAIR PIN	1
6	450066	BEARING	1	19	450067	I-BOLT 3/8-16 X 4 Z	1
7	450065	BEARING	1	20	166650	HANDLE NUT	2
8	450071	EXTENSION POLY	1	21	650513	KEY/WDRF#15 .25 X 1.0HT ALLOY	1
9	167864	50-B-20 SPROCKET	1	22	045026	RING/RETAINING	1
10	166975	SLOT COVER	1	23	450070	EXTENSION FRAME	2
11	D9130	SPROCKET/IDLER	1	24	049073 _a	MOTOR/HYDRAULIC	1
12	166976	SHIELD	1				
13	167862	50-B 72 SPROCKET	1				

a) See page 19 for individual components.

1840 - HYDRAULICS

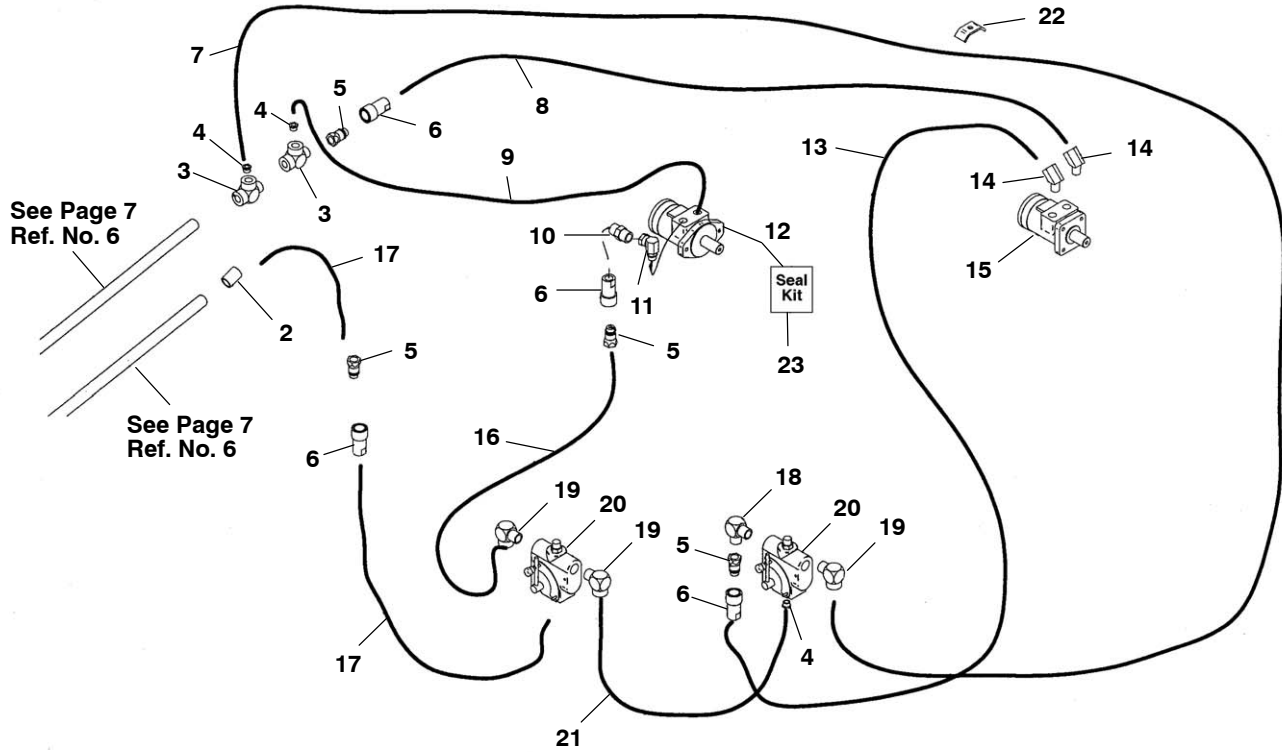

Ref. No.	Part No.	Description	Qty. Req.	Ref. No.	Part No.	Description	Qty. Req.
2	660055	COUPLING/PIPE 3/4	1	14	650685	ELBOW/HYD FITTING 45 DEG	2
3	660059	TEE/PIPE 3/4	2	15	049073 _a	HYDRAULIC MOTOR	1
4	660086	STR RED FP 3/4 X 1/2	3	16	167872	HYD HOSE 1/2 X 49 1/2 MP & 3/4 MP	1
5	100-32136	COUPLER HYD 3/4 NPT MALE HALF	4	17	167873	HYD HOSE 1/2 X 40 1/2 MP & 3/4 MP	1
6	100-32137	COUPLER HYD 3/4 NPT FML HALF	4	18	660010	ELBOW/PIPE .750 90 DEG	1
7	167866	HYD HOSE 1/2 X 77 3/4 MP & 1/2 MPX	1	19	660021	ELBOW/STREET .750 90 DEG	3
8	167869	HYD HOSE 1/2 X 144 1/2 MP & 3/4 MP	1	20	167865	3/4 FLOW CONTROL	2
9	167870	HYD HOSE 1/2 X 41 1/2 MP & #10	1	21	167874	HYD HOSE 1/2 X 33 3/4 MP & 1/2 MPX	1
10	069156	NIPPLE/PIPE ADAPTER	1	22	166073	HOSE HOLDER	AR
11	167875	ADAPTER/UNION 3/4 90 DEG & #10	1	23	172731	KIT/SEAL 2000 SERIES	1
12	166063	HYDRAULIC MOTOR	1				
13	167871	HYD HOSE 1/2 X 172 1/2 MP & 3/4 MP	1				

a) See page 19 for individual components.

Charlynn Motor

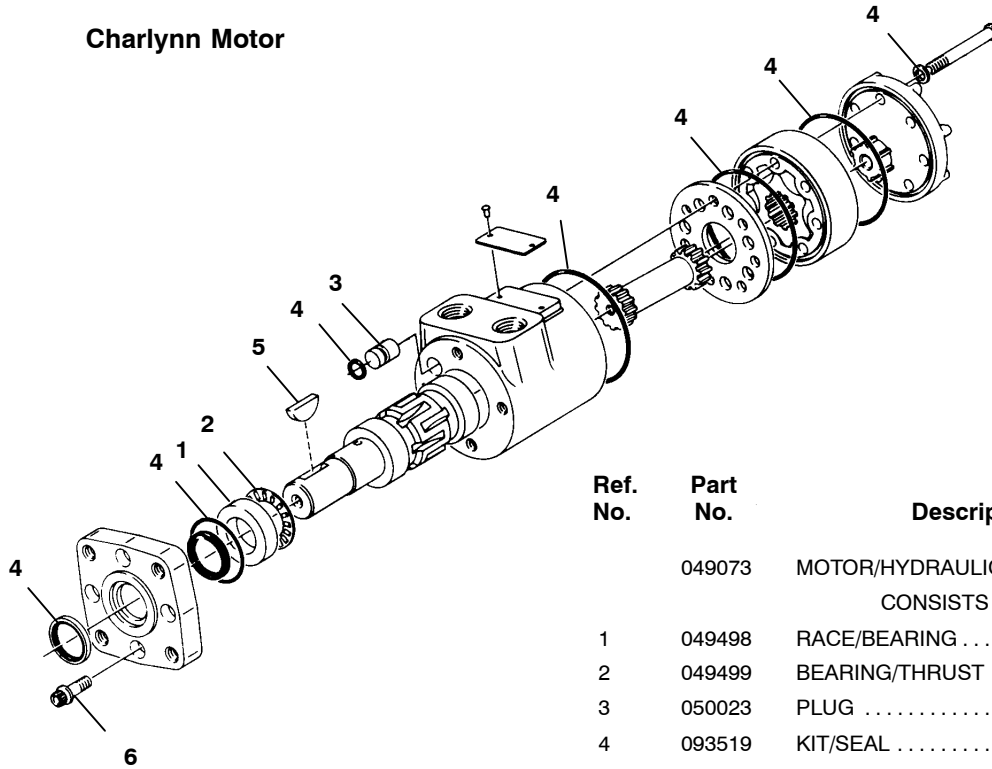

Ref. No.	Part No.	Description	Qty. Req.
	049073	MOTOR/HYDRAULIC	1
		CONSISTS OF:	
1	049498	RACE/BEARING	1
2	049499	BEARING/THRUST	1
3	050023	PLUG	1
4	093519	KIT/SEAL	1
5	650513	KEY/WOODRUFF 1/4X1	1
6	650927	SCREW/TPFH 5/16-24NFX7/8	4

1840 - OPTIONS (DEFLECTOR)

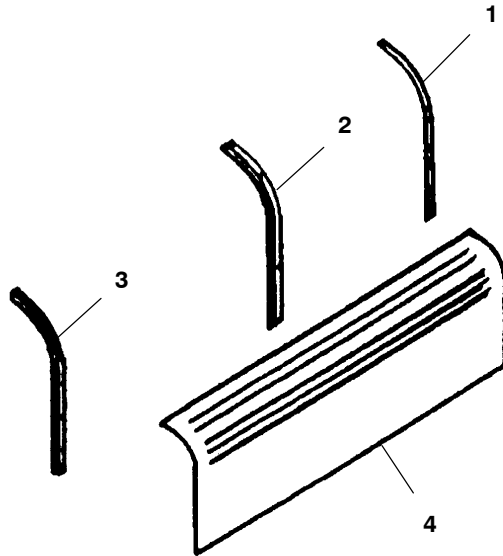

Ref. No.	Part No.	Description	(ALUMINIZED)		(POLY BONDED)
			20'	22'	24'
1	166274	LEFT RIDGE SUPPORT	1	1	1
2	166275	CENTER RIDGE SUPPORT	2	2	2
3	166277	RIGHT RIDGE SUPPORT	1	1	1
4	166278	DEFLECTOR	3	3	3

Index

A

Apron drive, 6–9
Auger unit, 17

B

Box components, 10–13

C

Chassis components, 14–15

D

Decal application, 2

Decal locations, 2–5

Deflector, 20

Door, 6–9

H

Hydraulics, 18

Components, 19

I

Idler, 6–9

Introduction, 2

L

Lights, 16

O

Options

Deflector, 20

P

Paint notice, 2

T

Tie down kit, 16

1840 - NUMERICAL INDEX

Part No.	Page No.	Ref. No.	Part No.	Page No.	Ref. No.	Part No.	Page No.	Ref. No.	Part No.	Page No.	Ref. No.
D9130	17	11	166061	09	25	166250	11	31	166304	13	04
H7812	09	25	166063	09	13	166251	09	30	166305	13	02
003938	15	19	166064	09	19	166252	09	31	166306	13	03
042162	15	17	166067	09	45	166253	09	33	166308	12	07
042163	15	18	166069	15	13	166254	09	41	166309	12	07
045026	17	22	166070	09	16	166255	07	07	166310	11	27
049073	17	24	166073	07	09	166256	09	42	166312	11	27
049073	18	12	166073	18	22	166257	07	49	166313	12	06
049073	18	15	166079	09	20	166258	09	32	166314	10	16
049073	19	00	166084	07	05	166260	10	01	166315	09	26
049498	19	01	166085	15	13	166261	10	01	166329	10	02
049499	19	02	166088	15	16	166262	10	04	166329	16	04
050023	19	03	166090	09	38	166263	10	07	166343	12	07
055365	09	39	166091	09	23	166264	10	08	166346	10	03
056230	09	48	166092	09	23	166265	07	08	166347	12	02
059060	16	09	166100	09	47	166266	10	09	166348	12	01
059070	16	11	166102	09	38	166267	10	12	166349	12	03
069156	18	10	166103	09	35	166268	10	15	166351	07	11
071706	16	03	166106	11	26	166269	10	16	166351	10	05
079152	15	22	166166	17	18	166270	11	17	166352	07	10
083107	15	21	166167	09	40	166271	11	18	166352	10	06
083108	15	14	166169	09	40	166272	11	19	166354	09	00
093366	02	14	166190	07	00	166273	11	20	166354	13	01
093367	02	08	166191	07	00	166274	20	01	166355	07	49
093373	02	10	166193	07	50	166275	20	02	166356	09	36
093444	02	05	166198	16	07	166277	20	03	166358	07	06
093519	19	04	166199	16	06	166278	20	04	166359	07	49
112190	15	15	166202	09	17	166279	11	25	166362	09	46
112191	15	14	166207	15	10	166280	10	15	166370	07	06
112917	16	10	166212	15	02	166281	11	17	166377	09	55
116072	15	16	166213	15	04	166282	10	09	166378	09	54
119514	16	01	166214	15	28	166283	10	12	166380	09	53
119661	02	11	166217	09	52	166284	11	27	166390	09	12
120403	15	21	166225	17	16	166285	09	15	166403	09	22
120433	15	17	166235	07	06	166287	09	00	166476	15	23
120434	15	18	166236	09	27	166289	11	28	166539	15	10
120538	15	22	166237	09	28	166290	11	29	166650	17	20
120617	15	19	166238	11	00	166291	11	28	166651	10	13
122616	02	01	166239	11	00	166292	11	29	166652	10	14
126530	15	36	166241	11	00	166293	11	28	166656	10	11
141266	14	25	166242	11	30	166294	11	29	166657	10	10
141268	15	24	166243	11	30	166298	13	06	166712	13	05
145216	02	12	166245	11	30	166299	12	04	166720	16	08
145217	02	06	166246	11	31	166300	12	05	166726	16	04
158061	15	24	166247	09	29	166302	13	04	166727	16	05
163957	02	07	166248	11	31	166303	13	05	166742	15	29
									166743	15	30

1840 - NUMERICAL INDEX







Part No.	Page No.	Ref. No.	Part No.	Page No.	Ref. No.	Part No.	Page No.	Ref. No.	Part No.	Page No.	Ref. No.
166744	15	31	166973	17	04	170670	16	03	650513	17	21
166745	15	32	166974	17	05	170673	16	05	650513	19	05
166746	15	33	166975	17	10	170671	15	05	650685	18	14
166747	15	34	167738	09	21	172731	18	23	650867	15	05
166748	15	35	167862	17	13	450065	17	07	650927	19	06
166761	09	37	167863	17	14	450066	17	06	650933	15	11
166805	07	50	167864	17	09	450067	17	19	651148	16	02
166806	07	51	167865	18	20	450068	17	17	651150	15	06
166811	07	01	167866	18	07	450069	17	01	651381	15	11
166844	07	04	167869	18	08	450070	17	23	651573	15	12
166857	15	09	167870	18	09	450071	17	08	653021	15	08
166858	15	09	167871	18	13	450072	17	02	654032	15	07
166864	15	03	167872	18	16	450073	17	03	655020	15	12
166884	09	34	167873	18	17	500057	17	15	660010	18	18
166885	07	02	167874	18	21	500087	09	19	660021	18	19
166886	07	03	167875	18	11	500160	09	18	660055	18	02
166900	09	14	170319	02	02	500195	09	18	660059	18	03
166901	09	44	170355	02	04	520013	15	15	660086	09	43
166908	09	14	170356	02	03	606065	09	39	660086	18	04
166909	09	24	170520	02	13	650453	16	01	100-32137	18	06
166965	16	02	170532	02	09	650484	15	20	100-32136	18	05
166970	17	12									

NOTES

TORQUE SPECIFICATIONS

NOTE: Use these torque values when tightening **GEHL** hardware (excluding: locknuts and self-tapping, thread forming and sheet metal screws) unless specified otherwise.

All torque values are in Lb-Ft., except those marked with an *, which are Lb-In.
(For metric torque value Nm, multiply Lb-Ft. value by 1.355 or Lb-In. value by 0.113.)

Unified National Thread	Grade 2 		Grade 5 		Grade 8 	
	Dry	Lubed	Dry	Lubed	Dry	Lubed
8-32 8-36	19* 20*	14* 15*	30* 31*	22* 23*	41* 43*	31* 32*
10-24 10-32	27* 31*	21* 23*	43* 49*	32* 36*	60* 68*	45* 51*
1/4-20 1/4-28	66* 76*	50* 56*	9 10	75* 86*	12 14	9 10
5/16-18 5/16-24	11 12	9	17 19	13 14	25	18 20
3/8-16 3/8-24	20 23	15 17	30 35	23 25	45 50	35
7/16-14 7/16-20	32 36	24 27	50 55	35 40	70 80	55 60
1/2-13 1/2-20	50 55	35 40	75 90	55 65	110 120	80 90
9/16-12 9/16-18	70 80	55 60	110 120	80 90	150 170	110 130
5/8-11 5/8-18	100 110	75 85	150 180	110 130	220 240	170 180
3/4-10 3/4-16	175 200	130 150	260 300	200 220	380 420	280 320
7/8-9 7/8-14	170 180	125 140	430 470	320 360	600 660	460 500
1-8 1-14	250 270	190 210	640 710	480 530	900 1000	680 740
Metric Course Thread	Grade 8.8 		Grade 10.9 		Grade 12.9 	
	Dry	Lubed	Dry	Lubed	Dry	Lubed
M6-1	8	6	11	8	13.5	10
M8-1.25	19	14	27	20	32.5	24
M10-1.5	37.5	28	53	39	64	47
M12-1.75	65	48	91.5	67.5	111.5	82
M14-2	103.5	76.5	145.5	108	176.5	131
M16-2	158.5	117.5	223.5	165.5	271	200

GEHL®

Gehl Company 143 Water Street, P.O. Box 179, West Bend, WI 53095-0179 U.S.A.
(www.gehl.com)